

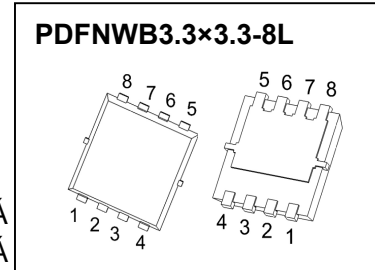

**PDFNWB3.3×3.3-8L Plastic-Encapsulate MOSFETS**

**CJAB65N04 N-Channel Power MOSFET**

$V_{(BR)DSS}$	$R_{DS(on)TYP}$	$I_D$
1 €X	4.8{ 0 F€X	6í OE
	6.2{ 0 I ĚX	



**DESCRIPTION**

V@ÔRÖÖí p€I Á••Áççç &áÁ^} &@^&@ [ [ \* ^ Áççç áÁ^•ã } Á ç Á [ çãÁ ç&||^} ÖÜÖÜPD, Á ççç, Á ççç &@\* ^ Áççç Á^Á•^áÁ Á, çãÁçãç Á Áççç ] çãçç } •Á

**FEATURES**

- Pã ççç, ^íÁççç áÁ^ ||^} ççç çãçç \* Áççç çãçç
- Š çãÁ, çãçç
- Pã çãçç } çãçç ||Á^•ã } Áççç Á çãçç, ÁÜÖÜPD
- Š çãÁ^Áççç [ çãçç çãçç çãçç
- Ö [ [ áÁ çãçç çãçç çãçç ] çãçç çãçç çãçç çãçç
- Ö çãçç ||^} çãçç çãçç ^Áççç [ [ áÁ çãçç çãçç çãçç ]

**APPLICATIONS**

- ÚT ÚÜÁççç áÁ^} çãçç çãçç [ [ • ^ Áççç ] çãçç } •
- Pã çãÁ, çãçç çãçç çãçç çãçç çãçç çãçç & çãçç çãçç
- W çãçç çãçç çãçç çãçç [ [ ^ Áççç ] ] çãçç
- Ú [ , ^íÁ çãçç çãçç ^ } çãçç

**MARKING**



ÔRÖÖí p€I ÁMÁçççÁp [ Ě  
 Ú [ çãÁá [ çMÚç FÁçç çãçç ] : Á  
 ÝÝMÖ [ áÁ.Á

**EQUIVALENT CIRCUIT**

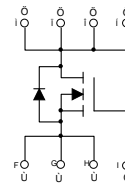

**MAXIMUM RATINGS ( T<sub>a</sub>=25°C unless otherwise noted )**

Parameter	Symbol	Limit	Unit
Ö: çãçç ĚÜ [ ~ ! & ^ Áççç ] çãçç ^ Á	X <sub>ÖÜÁ</sub>	1 €Á	XÁ
Ö çãçç ĚÜ [ ~ ! & ^ Áççç ] çãçç ^ Á	X <sub>ÖÜÁ</sub>	† GEÁ	XÁ
Ô [ ] çãçç [ ~ • ÁÖ: çãçç ÁÖ^   ^ } çãçç	Q <sub>ÁD</sub>	6í Á	ÖÁ
Ú [ ] • ^ áÁÖ: çãçç ÁÖ^   ^ } çãçç	Q <sub>TÁD</sub>	24€Á	ÖÁ
Úççç * ^ Áççç [ ] • ^ áÁÖ: çãçç çãçç & @ ÁÖ: ^ í * ^ Á	Ö <sub>ÖÜÁ</sub>	FGE	{ RÁ
Ú [ , ^ í Áççç çãçç çãçç ] Á	Ú <sub>ÖÁD</sub>	57	Y Á
V@! { çãçç Á^•ã çãçç & Áççç [ { Áççç } & çãçç ] Áççç Áççç çãçç	Ü <sub>ROÁ</sub>	83.3	°C BY Á
V@! { çãçç Á^•ã çãçç & Áççç [ { Áççç } & çãçç ] Áççç Áççç CaseÁ	Ü <sub>RCÁ</sub>	2.2	°C BY Á
Operating R } & çãçç ] Áççç and Úççç çãçç Á^Á^ [ ] ^ í çãçç [ ^ Áççç ] * ^ Á	V <sub>RÁT stg</sub>	Ě í Áççç €Á	°C

# MOSFET ELECTRICAL CHARACTERISTICS

$T_a=25\text{ }^\circ\text{C}$  unless otherwise specified

Parameter	Symbol	Test Condition	Min	Typ	Max	Unit
<b>Off characteristics</b>						
Drain-source breakdown voltage	$V_{(BR)DSS}$	$V_{GS} = 0V, I_D = 250\mu A$	40			V
Zero gate voltage drain current	$I_{DSS}$	$V_{DS} = 32V,$ $V_{GS} = 0V$	$T_J = 25\text{ }^\circ\text{C}$		1.0	$\mu A$
			$T_J = 125\text{ }^\circ\text{C}$		100	
Gate-body leakage current	$I_{GSS}$	$V_{DS} = 0V, V_{GS} = \pm 20V$			$\pm 100$	nA
<b>On characteristics</b> ④						
Gate-threshold voltage	$V_{GS(th)}$	$V_{DS} = V_{GS}, I_D = 250\mu A$	1.0	1.7	2.5	V
Static drain-source on-state resistance	$R_{DS(on)}$	$V_{GS} = 10V, I_D = 20A$		4.8	6.0	m $\Omega$
		$V_{GS} = 4.5V, I_D = 10A$		6.2	8.0	m $\Omega$
Forward transconductance	$g_{FS}$	$V_{DS} = 10V, I_D = 10A$		15		S
<b>Dynamic characteristics</b> ④ ⑤						
Input capacitance	$C_{ISS}$	$V_{DS} = 25V, V_{GS} = 0V,$ $f = 1MHz$		2540	3540	$\mu F$
Output capacitance	$C_{OSS}$			218	420	
Reverse transfer capacitance	$C_{RSS}$			178	247	
Gate resistance	$R_g$	$f = 1MHz$		1.6		$\Omega$
<b>Switching characteristics</b> ④ ⑤						
Total gate charge	$Q_g$	$V_{DS} = 32V, V_{GS} = 4.5V,$ $I_D = 10A$		25.2	54	nC
Gate-source charge	$Q_{gs}$			5.3	14	
Gate-drain charge	$Q_{gd}$			12.5	23	
Turn-on delay time	$t_{d(on)}$	$V_{DS} = 20V, I_D = 1A,$ $V_{GS} = 10V, R_G = 3\Omega$		13.7	30	ns
Turn-on rise time	$t_r$			19.2	40	
Turn-off delay time	$t_{d(off)}$			40	80	
Turn-off fall time	$t_f$			13	30	
<b>Drain-Source Diode Characteristics</b>						
Drain-source diode forward voltage	$V_{SD}$ ④	$V_{GS} = 0V, I_S = 10A$			1.2	V
Continuous drain-source diode forward current	$I_S$ ①				65	A
Pulsed drain-source diode forward current	$I_{SM}$ ②				240	A

Notes:

- $T_C = 25\text{ }^\circ\text{C}$  Limited only by maximum temperature allowed.
- $P_W \leq 10\mu s$ , Duty cycle  $\leq 1\%$ .
- EAS condition:  $V_{DD} = 20V, V_{GS} = 10V, L = 0.1mH, R_g = 25\Omega$  Starting  $T_J = 25\text{ }^\circ\text{C}$ .
- Pulse Test : Pulse Width  $\leq 300\mu s$ , duty cycle  $\leq 2\%$ .
- Guaranteed by design, not subject to production.
- The value of  $R_{\theta JA}, R_{\theta JC}$  is measured with the device mounted on 1 in 2 FR-4 board with 2oz. Copper, in a still air environment with  $T_a = 25\text{ }^\circ\text{C}$ .

# MOSFET ELECTRICAL CHARACTERISTICS

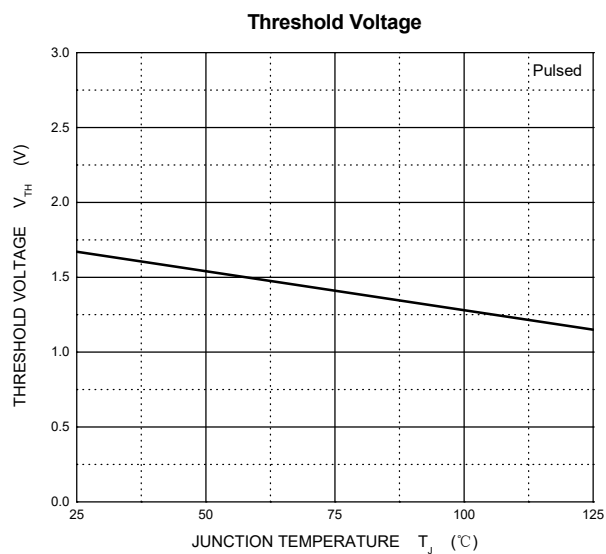
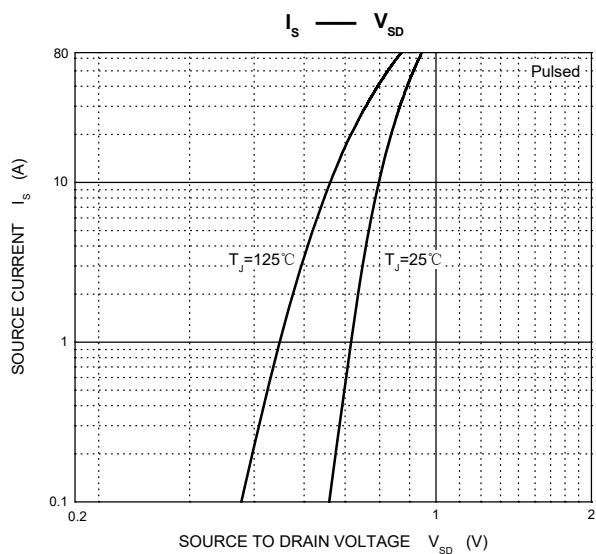
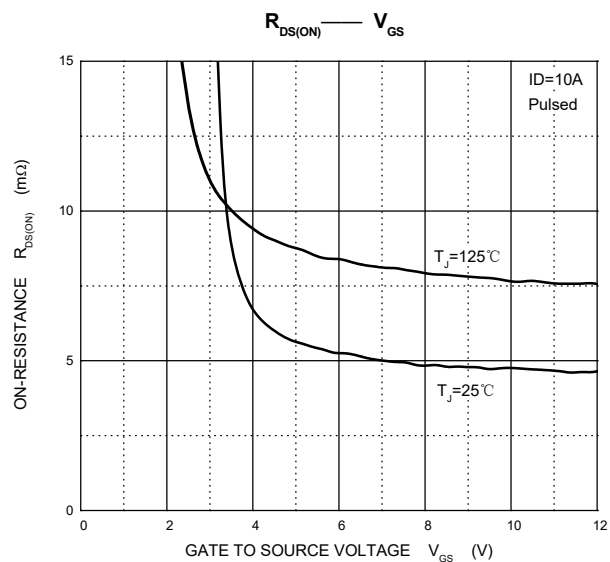
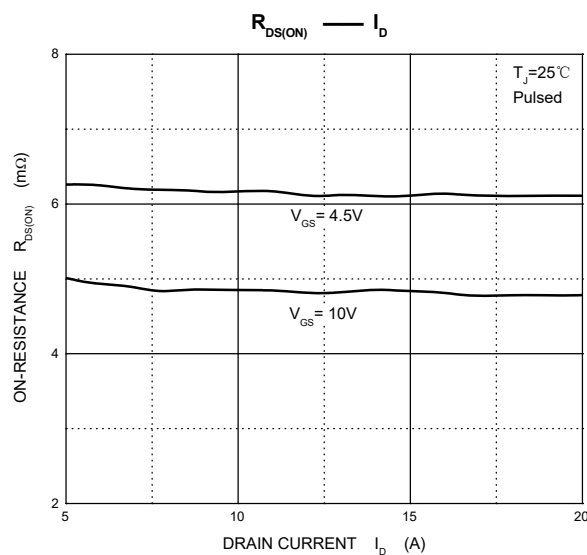
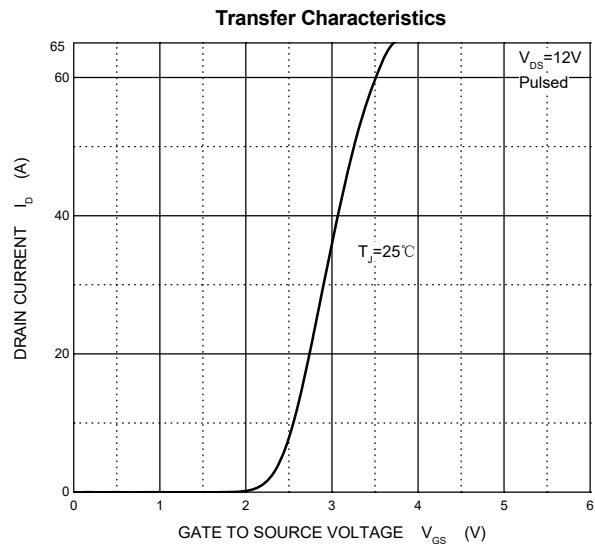
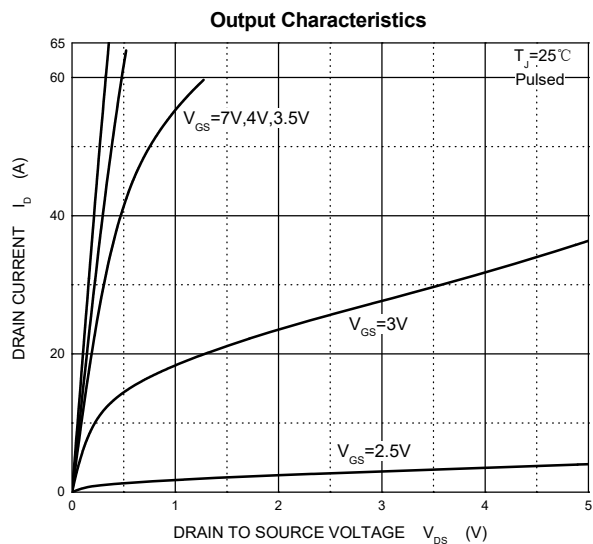

Capacitances

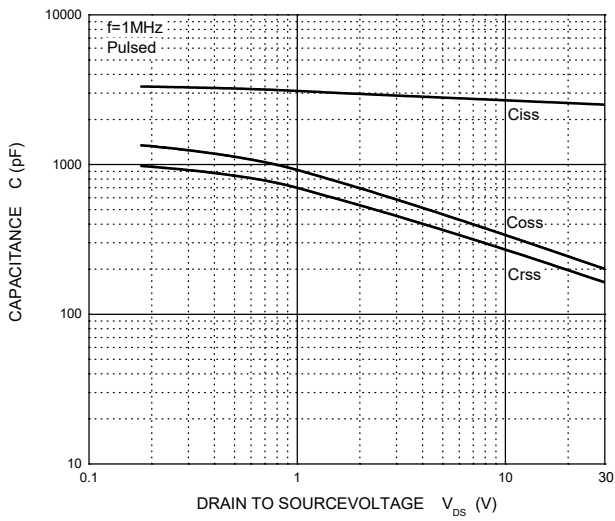

Gate Charge

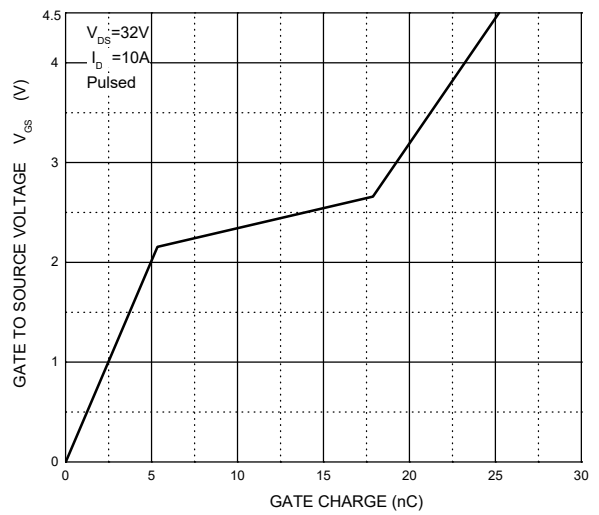

NORMALIZED TRANSIENT THERMAL IMPEDANCE

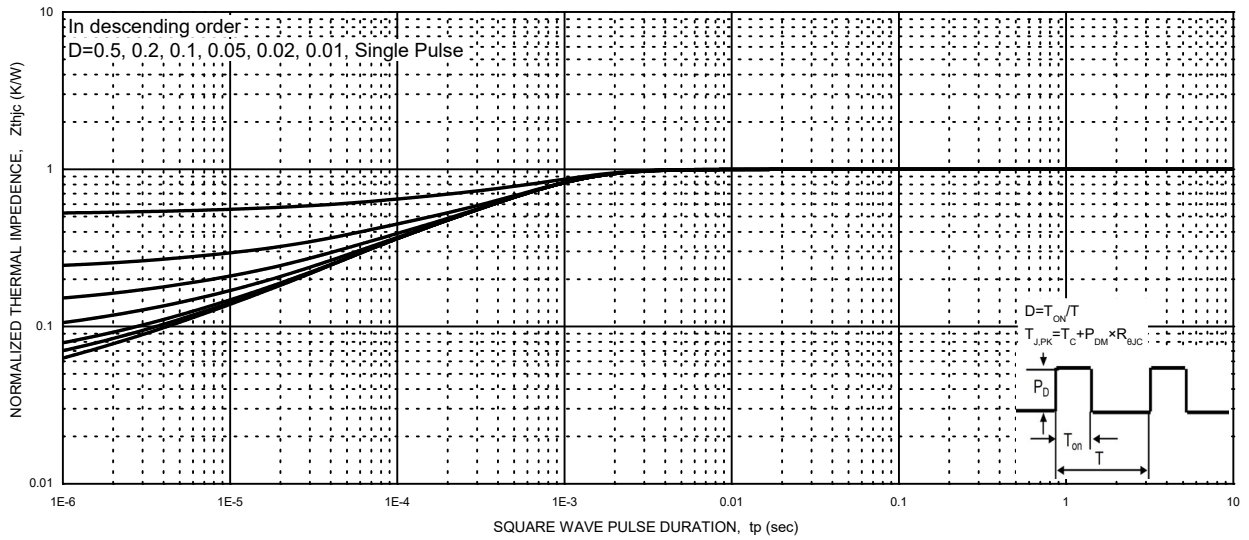

MAXIMUM FORWARD BIASED SAFE OPERATING AREA

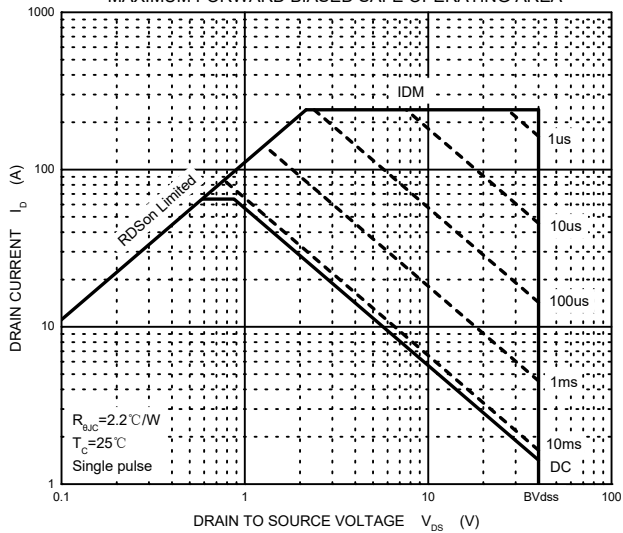

## PDFNWB3.3x3.3-8L Package Outline Dimensions

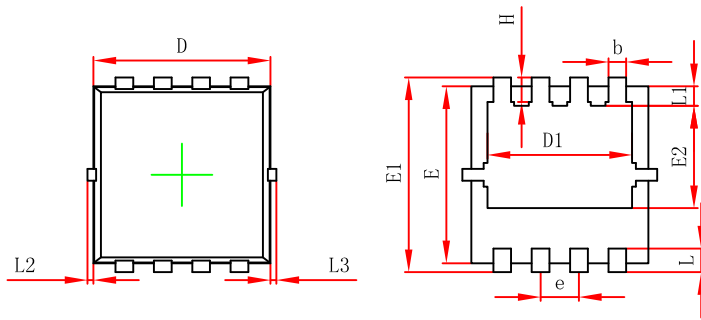

Top View  
[顶视图]

Bottom View  
[背视图]

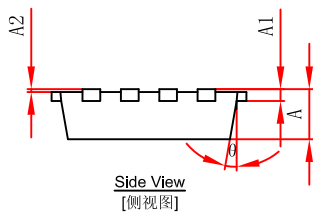

Side View  
[侧视图]

Symbol	Dimensions In Millimeters		Dimensions In Inches	
	Min.	Max.	Min.	Max.
A	0.650	0.850	0.026	0.033
A1	0.152 REF.		0.006 REF.	
A2	0-0.05		0-0.002	
D	2.900	3.100	0.114	0.122
D1	2.300	2.600	0.091	0.102
E	2.900	3.100	0.114	0.122
E1	3.150	3.450	0.124	0.136
E2	1.535	1.935	0.060	0.076
b	0.200	0.400	0.008	0.016
e	0.550	0.750	0.022	0.030
L	0.300	0.500	0.012	0.020
L1	0.180	0.480	0.007	0.019
L2	0-0.100		0-0.004	
L3	0-0.100		0-0.004	
H	0.315	0.515	0.012	0.020
θ	9°	13°	9°	13°

## PDFNWB3.3x3.3-8L Suggested Pad Layout

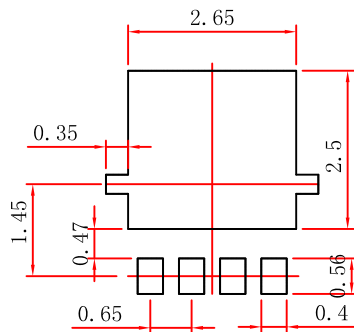

### Note:

1. Controlling dimension: in millimeters.
2. General tolerance:  $\pm 0.05$  mm.
3. The pad layout is for reference purposes only.

### NOTICE

JSCJ reserves the right to make modifications, enhancements, improvements, corrections or other changes without further notice to any product herein. JSCJ does not assume any liability arising out of the application or use of any product described herein.

# PDFNWB3.3×3.3-8L Tape and Reel

## PDFNWB3.3×3.3-8L Embossed Carrier Tape

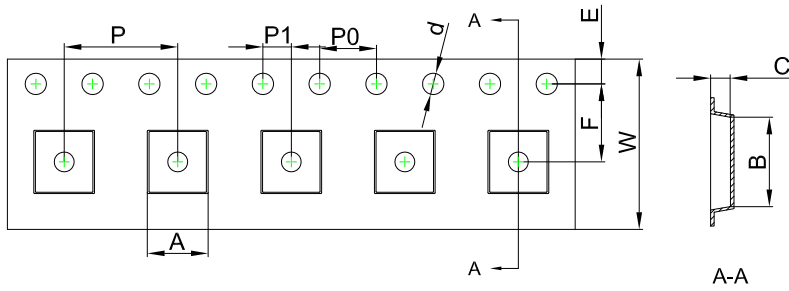

### Packaging Description:

**PDFNWB3.3×3.3-8L** parts are shipped in tape. The carrier tape is made from a dissipative (carbon filled) polycarbonate resin. The cover tape is a multilayer film (Heat Activated Adhesive in nature) primarily composed of polyester film, adhesive layer, sealant, and anti-static sprayed agent. These reeled parts in standard option are shipped with 5,000 units per 13" or 33.0 cm diameter reel. The reels are clear in color and is made of polystyrene plastic (anti-static coated).

Dimensions are in millimeter										
Pkg type	A	B	C	d	E	F	P0	P	P1	W
PDFNWB3.3×3.3-8L	3.55	3.55	1.10	Ø1.50	1.75	5.50	4.00	8.00	2.00	12.00

## PDFNWB3.3×3.3-8L Tape Leader and Trailer

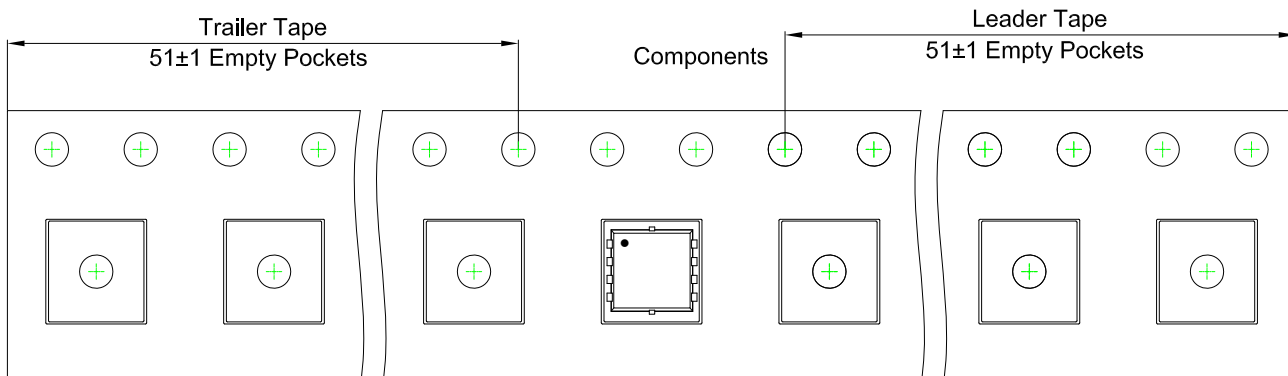

## PDFNWB3.3×3.3-8L Reel

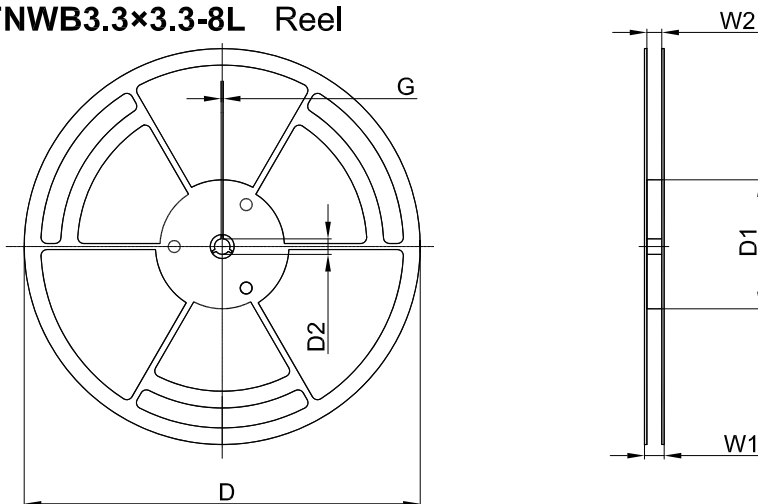

Dimensions are in millimeter						
Reel Option	D	D1	D2	G	W1	W2
13" Dia	Ø330.00	100.00	13.00	1.90	17.60	12.40

REEL	Reel Size	Box	Box Size(mm)	Carton	Carton Size(mm)
5,000 pcs	13 inch	5,000 pcs	340×336×29	50,000 pcs	353×346×365