

DESCRIPTION

The TCS5290 is a high efficiency boost regulator with 6 channel current sinker which is ideal for media size LCD backlighting applications.

The device with integrated 2.5A/43V power MOSFET uses current mode architecture and drives six strings in parallel and supports up to 10 pieces of LEDs per string. The switching frequency is programmable by an external frequency setting resistor. The TCS5290 regulates the current in each LED string to the programmed value set by an external current setting resistor. The TCS5290 current matching can achieve $\pm 2\%$. To provide enough headroom for the operating of current sink, boost converter monitors the minimum voltage of feedback pins and regulates an optimized output voltage for power efficiency.

The TCS5290 has wide input voltage range from 2.5V to 24V and provides adjustable 5mA to 50mA LED current. It provides cycle-by-cycle over current protection. The device supports PWM dimming functions for accurate LED current control.

The TCS5290 integrated multiple protect functions, such as LED open, LED short, output over voltage, over thermal and under voltage lockout, these protections will prevent the LCD backlight from damage.

The TCS5290 is available in a 3×3mm TQFN-20L package.

FEATURES

- 2.5V to 24 V Input Voltage
- 6 Strings in Parallel and Up to 10 WLEDs Per String
- Integrated 2.5A 43V MOSFET
- Output Voltage Up to 43V
- Programmable Full Channel Current from 5mA to 50mA
- Direct PWM Dimming up to 20kHz
- Better Than 2% Current Regulation Accuracy Between Strings
- Multiple Fault Protections
 - Current Limit Protection
 - Over Voltage Protection
 - Over Temperature Protection
 - WLED Open/Short Protection
- Available in 3mm×3mm TQFN-20 Package
- RoHS Compliant and 100% Lead (Pb)-Free Halogen-Free

APPLICATIONS

- Notebook LCD Display Backlight
- UMPC LCD Display Backlight

Typical Application Circuit

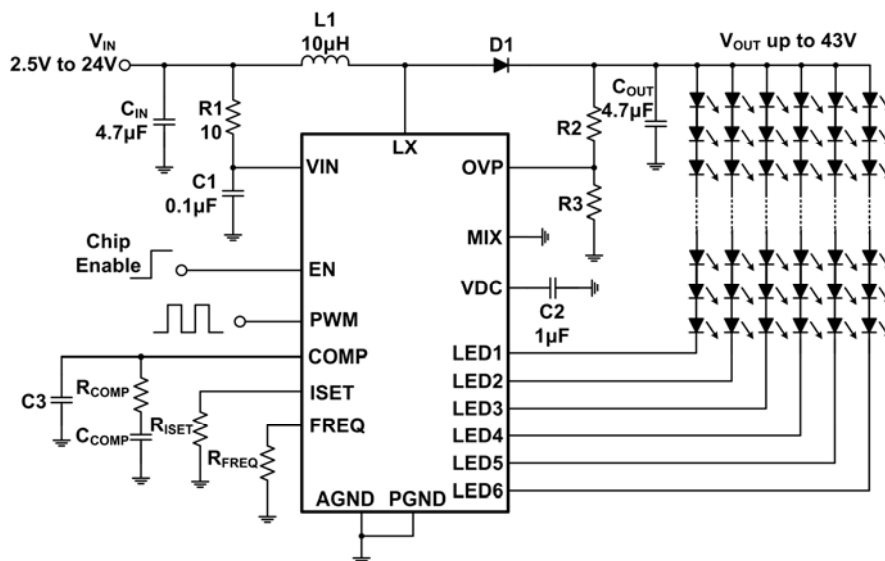
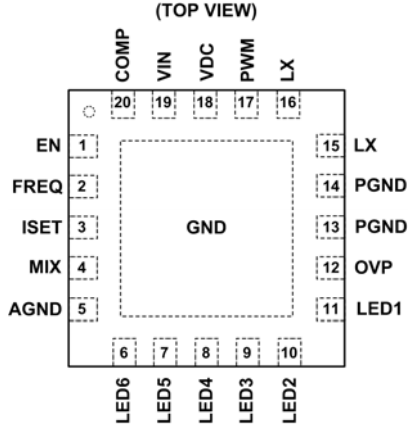

Figure 1.

Pin Configurations

Package Type	Pin Configurations
TQFN-20	<p>(TOP VIEW)</p>  <p>The diagram shows a square package with pins numbered 1 to 20. Pin 1 (EN) is at the top left, pin 2 (FREQ) is below it, pin 3 (ISET) is below that, pin 4 (MIX) is below that, and pin 5 (AGND) is at the bottom left. Pins 6-11 (LED6-LED1) are along the bottom edge. Pins 12 (OVP), 13 (PGND), 14 (PGND), and 15 (LX) are along the right edge. Pins 16 (LX), 17 (PWM), 18 (VDC), 19 (VIN), and 20 (COMP) are along the top edge. A central square area is labeled GND.</p>

Pin Description

PIN	TQFN-20	DESCRIPTION
1	EN	Chip enable pin (active high). There is an internal pull low resistor connected to AGND.
2	FREQ	Switching frequency of Boost converter setting input. Connect a resistor to ground.
3	ISET	LED current is set by the value of the resistor R_{ISET} Connected from the ISET pin to ground. V_{ISET} is around 1V, during full lighting, $I_{LEDX}=240/R_{ISET}$. Set $R_{ISET}=12K\Omega$, I_{LEDX} is set to 20mA.
4	MIX	Short this pin to ground.
5	AGND	Analog Ground of LED Driver.
6~11	LED6 ~ LED1	Current Sink for LED String. (Leave the pin unconnected or short to GND, if not used.)
12	OVP	Over voltage protection for Boost converter. Connect OVP to the tap point of the resistor divider between output and ground. The detecting threshold is 1.2V.
13,14	PGND	Power ground of Boost converter.
15,16	LX	The switching for Boost converter. Drain of the internal power NMOS.
17	PWM	PWM dimming control input.
18	VDC	Internal regulator voltage. Bypass VDC to ground with a ceramic capacitor.
19	VIN	Supply voltage input.
20	COMP	Boost converter compensation pin. Connect a compensation network to ground.
Thermal Pad	GND	The exposed pad must be soldered to a large PCB and connected to GND for maximum power dissipation.

Ordering Information

Order Number	Package Type	Marking	Operating Temperature Range
TCS5290_QT	TQFN-20		-40 °C to +85°C

Block Diagram

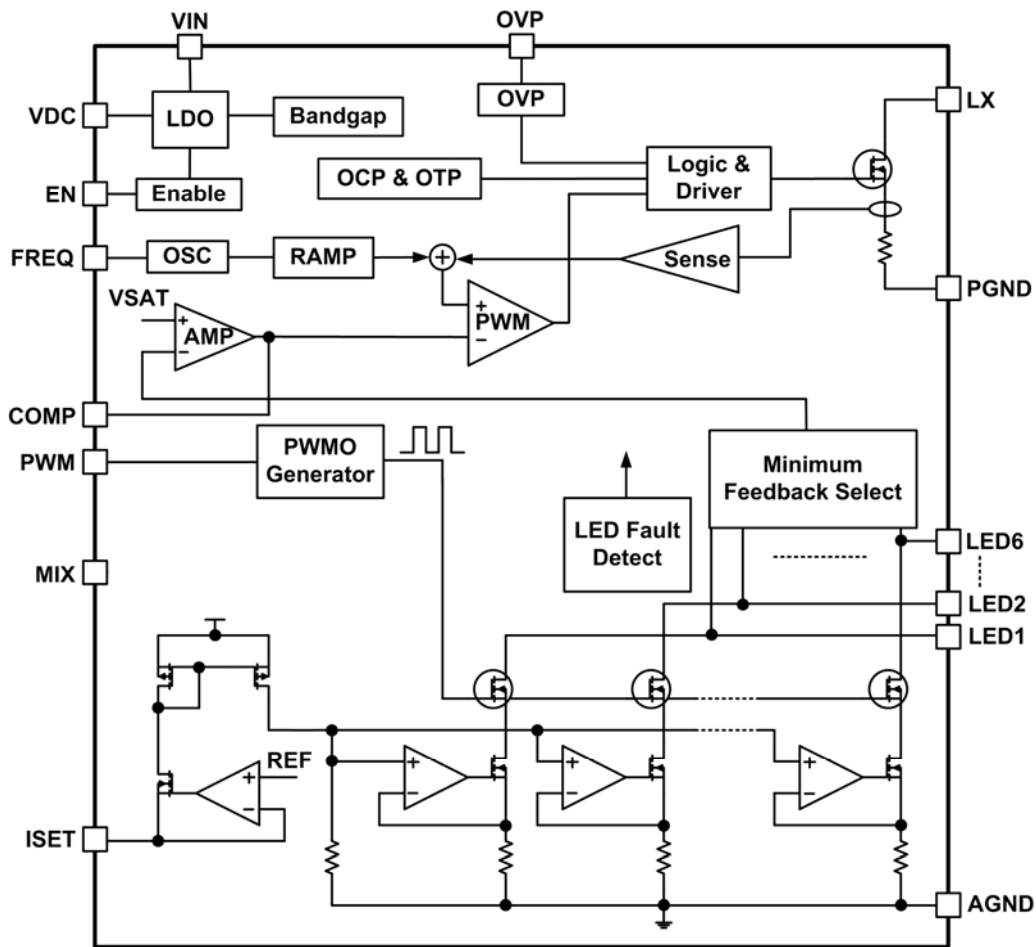

Figure 2.

Absolute Maximum Ratings (1)

■ VIN to GND -----	-0.3V to +30V
■ EN, PWM, ISET, COMP, MIX, FREQ to GND -----	-0.3V to +30V
■ LX, OVP, LED1 to LED6 to GND -----	-0.3V to +45V
■ VDC to GND -----	-0.3V to +6V
■ PGND to GND -----	-0.3V to +0.3V
■ Continuous Power Dissipation (T _A = +25°C) TQFN3×3-20 -----	2.083W
■ Package Thermal Resistance, θ _{JA} (TQFN-20) -----	60°C/W
■ Junction Temperature -----	+150°C
■ Storage Temperature Range -----	-60°C to +150°C
■ Lead Temperature (Soldering, 10sec) -----	260°C
■ ESD Rating Human Body Model -----	2kV

Recommended Operating Conditions (2)

■ Battery Input Voltage (VIN) -----	2.5V to 24V
■ Operating Temperature Range -----	-40°C to +85°C

Note (1): Stress beyond those listed under “Absolute Maximum Ratings” may damage the device.

Note (2): The device is not guaranteed to function outside the recommended operating conditions

Electrical Characteristics

(V_{IN}=5V, R_{ISET}=12KΩ, T_A= -40°C to 85°C, unless otherwise specified. Typical values are at T_A= +25°C.)

			TCS5290			Unit
			Min.	Typ.	Max.	
V _{IN}	Input voltage		2.5		24	V
I _{VIN_NOSW}	VIN Quiescent Current	V _{PWM} =V _{COMP} =0V, No Switching		3		mA
I _{VIN_SW}		V _{PWM} =V _{COMP} =2V, Switching		4		
I _{SHDN}	VIN Shutdown Current	V _{IN} =4.5V, V _{EN} =0V			10	μA
V _{IN_UVH}	VIN Under Voltage Lockout Threshold	V _{IN} Rising		2.3		V
V _{IN_UVL}		V _{IN} Falling		2.1		
V _{IH}	EN, PWM, MIX Input Voltage	V _{IN} =2.5V to 24V	2			V
V _{IL}		V _{IN} =2.5V to 24V			0.8	
Boost Converter						
F _{SW}	Switching Frequency	R _{FSW} =51KΩ		500		KHz
D _{MAX}	Maximum Duty Cycle	F _{SW} =1MHz		92		%
T _{ON_MIN}	Minimum On Time	F _{SW} =1MHz		80		ns
R _{ON_LX}	LX On Resistance			0.2		Ω
I _{LIM}	Boost Current Limit			2.5		A
LED Current Regulation						
V _{LEDX}	Regulated V _{LEDX}	I _{LED} =20mA		0.5		V
I _{LEDA}	Output LED Current	R _{ISET} =12KΩ	19.2	20	20.8	mA
I _{LEDM}	LED Current Matching	R _{ISET} =12KΩ	-2		2	%
V _{ISET}	ISET Regulation Voltage			1		V
Fault Protection						
V _{OVP}	OVP Threshold	Rising Edge		1.2		V
V _{OVPS}	OVP Short Threshold			50		mV
T _{SD}	Thermal Shutdown Threshold			150		°C
T _{SD_HYS}	Thermal Shutdown Hysteresis			15		°C
V _{LED_UV}	LED Pin Under Voltage Threshold			0.17		V

Typical Operating Characteristics

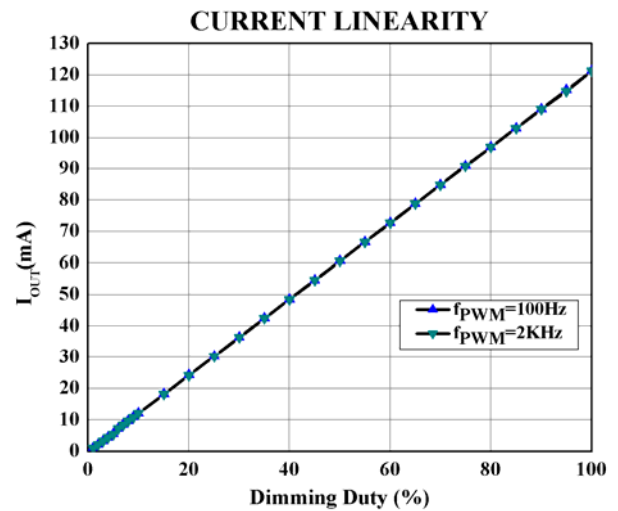
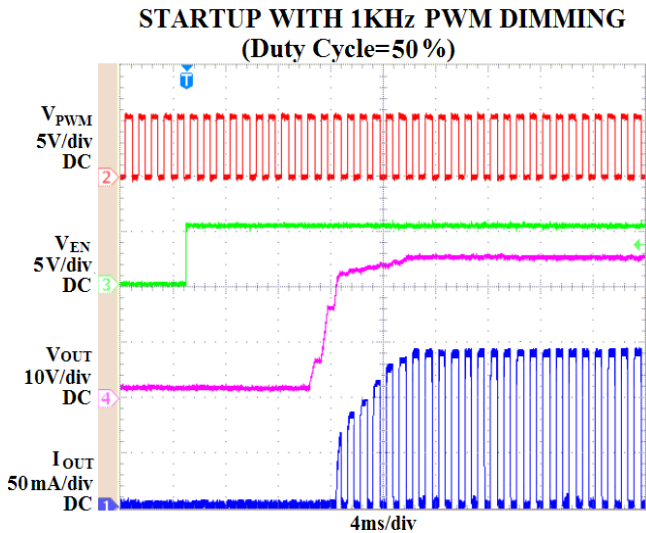
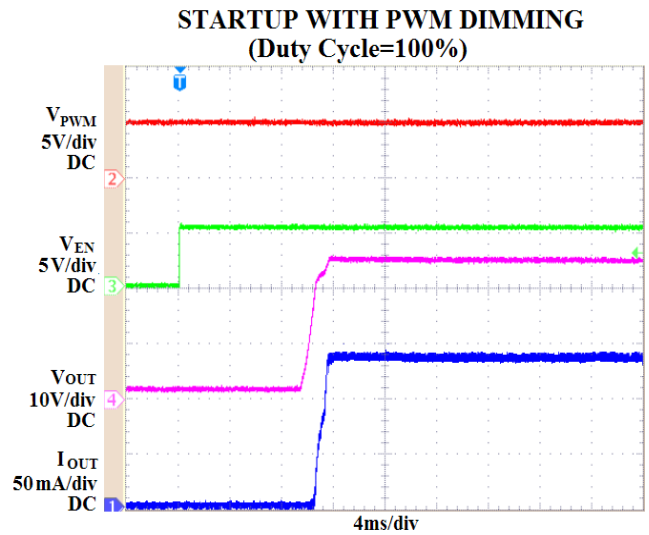
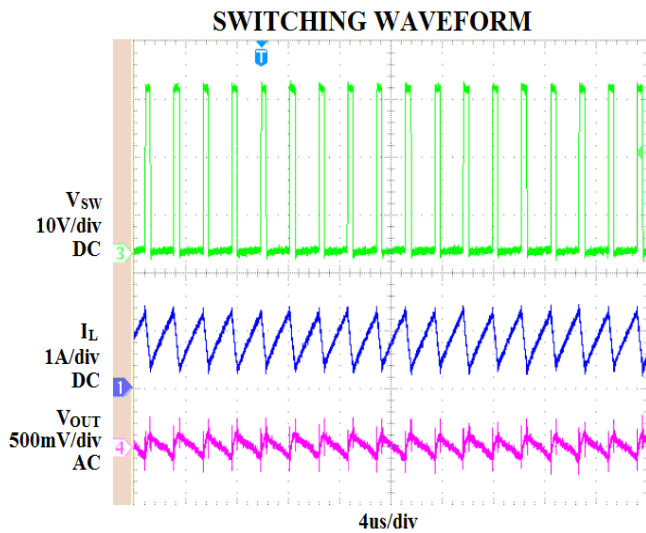
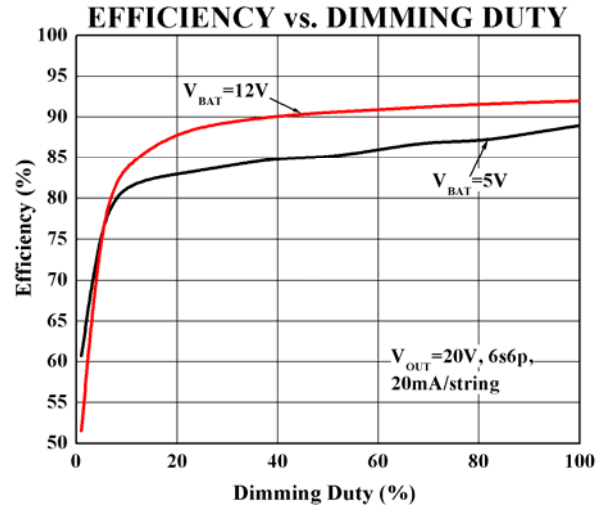
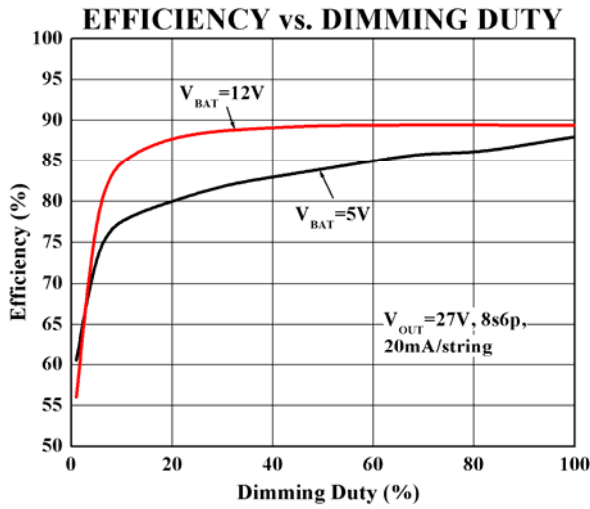

Typical Operating Characteristics (Continued)

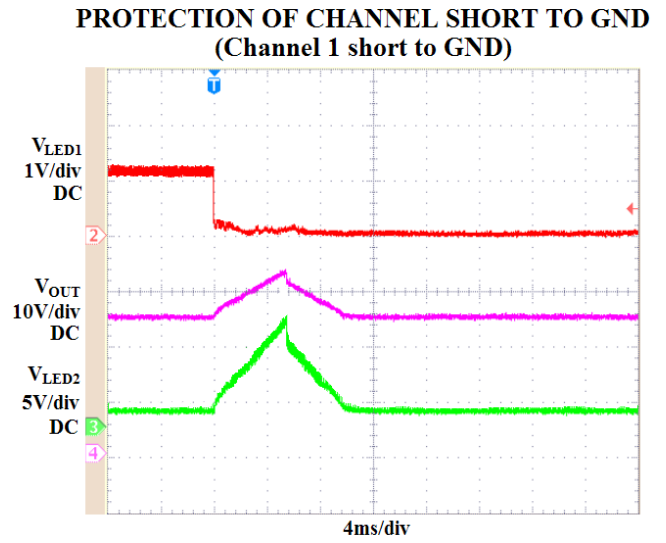
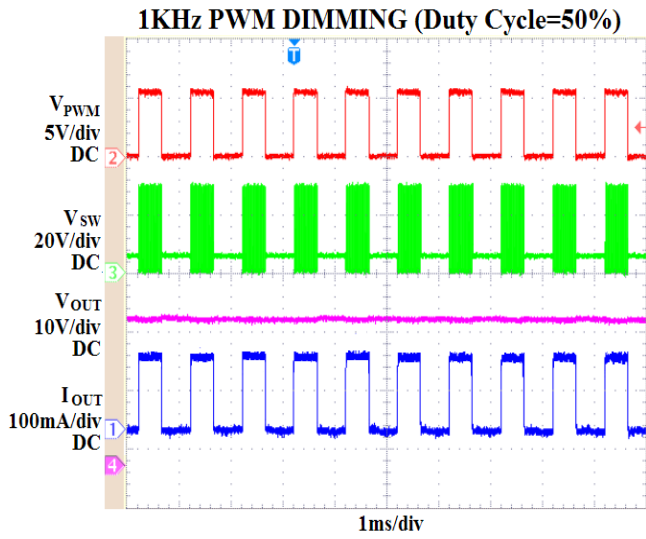

Detailed Descriptions

The TCS5290 is a high-efficiency driver for arrays of white LEDs. It contains a current mode, PWM step-up converter with 2.5A/43V power MOSFET, linear regulator and 6 channel regulated current sources. Each channel can provide adjustable 5mA to 50mA LED current. When enabled, the step-up converter boosts the output voltage to provide sufficient headroom for the current sources to regulate their respective string currents. The control architecture automatically skips pulses at light loads to improve efficiency and prevents overcharging the output capacitor. The TCS5290 integrates PWM dimming function for accurate LED current control. It also has multiple features to protect the converter from fault conditions. Separate feedback loops limit the output voltage if one or more LEDs fail open or short. The converter features cycle-by-cycle current limit to provide consistent operation. A thermal-shutdown circuit provides another level of protection.

System Startup

A logic high signal on the EN pin turns on the internal linear regulator which provides supply to the IC current. The soft start time of the LED boost converter is several tens of milliseconds according to the compensation capacitor on the COMP pin.

Step-up Converter

The Step-up regulator is a high efficiency current-mode PWM architecture. The converter automatically chooses the lowest active LEDX voltage to regulate the output voltage.

As the load changes, the error amplifier sources or sinks current to the COMP output to deliver the required peak-inductor current. The slope-compensation signal is added to the current-sense signal to improve stability at high duty cycles.

At light-load or V_{OUT} near to V_{IN} operation, the converter runs into the pulse-skipping mode, the FET is turned on for a minimum on-time of approximately 80ns, and then the converter discharges the power to the output in the remain period. The MOSFET will keep off until the output voltage needs to be boosted again.

Setting and Regulation of LED Current

The six current sink regulators embedded in TCS5290 can output from 5mA to 50mA current each. The full-scale current per channel is programmed by the resistor at ISET pin according to the equation:

$$I_{LED}(mA) = 240/R_{ISET}(K\Omega)$$

Where R_{ISET} is the resistor between the ISET pin and GND.

The DC/DC converter regulates the LED current according to the setting.

Dimming Control

The TCS5290 provides direct PWM dimming mode for accurate LED current control. An external PWM dimming signal is employed to achieve PWM dimming control. The current source turn-on/off is synchronized with the PWM signal. The brightness of the LED array is proportional to the duty cycle of the PWM signal.

Over-Current and Over-Voltage Protection

The TCS5290 has pulse-by-pulse over-current limit of 2.5A (typ.). The PWM switch turns off when the inductor current reaches this current threshold. The PWM switch remains off until the beginning of the next switching cycle. This protects the IC and external components under over-load conditions.

The output voltage of the boost converter is detected by OVP pin. When the voltage at the OVP pin reaches a threshold of approximately 1.2V, the driver will turn off. The driver will turn on again when the voltage at OVP drops a certain voltage below 1.2V. The output OVP threshold can be programmed by an external resistor divider and calculated by the following equation:

$$V_{OUT_OVP} = 1.2 \times \left(\frac{R2 + R3}{R3} \right)$$

LED Open String Protection

If one of the WLED strings is open, the IC keeps charging the output voltage until it reaches OVP threshold. Then the part will mark-off the open string. As a result, the IC removes the open LED pin from the voltage feedback loop. Subsequently, the output voltage drops down and is regulated to a voltage for the connected WLED strings. The LED current of the connected WLED strings keep in regulation during the whole transition. The TCS5290 always tries to light at least one string and if all strings in use are open, the TCS5290 shuts down the step-up converter.

LED Pin Unused

If the application requires less than 6 WLED strings, one can easily disable unused LED pins. The TCS5290 simply requires leaving the unused LED pin open or shorting it to ground. If the LED pin is open, the boost output voltage ramps up to V_{OUT} over voltage threshold during start up. The IC then detects the zero current string, and removes it from the feedback loop. If the LED pin is shorted to ground, the IC detects the short immediately after IC enable, and the boost output voltage does not go up to V_{OUT} over voltage threshold. Instead, it ramps to the regulation voltage after soft start.

Packaging Information

TQFN-20

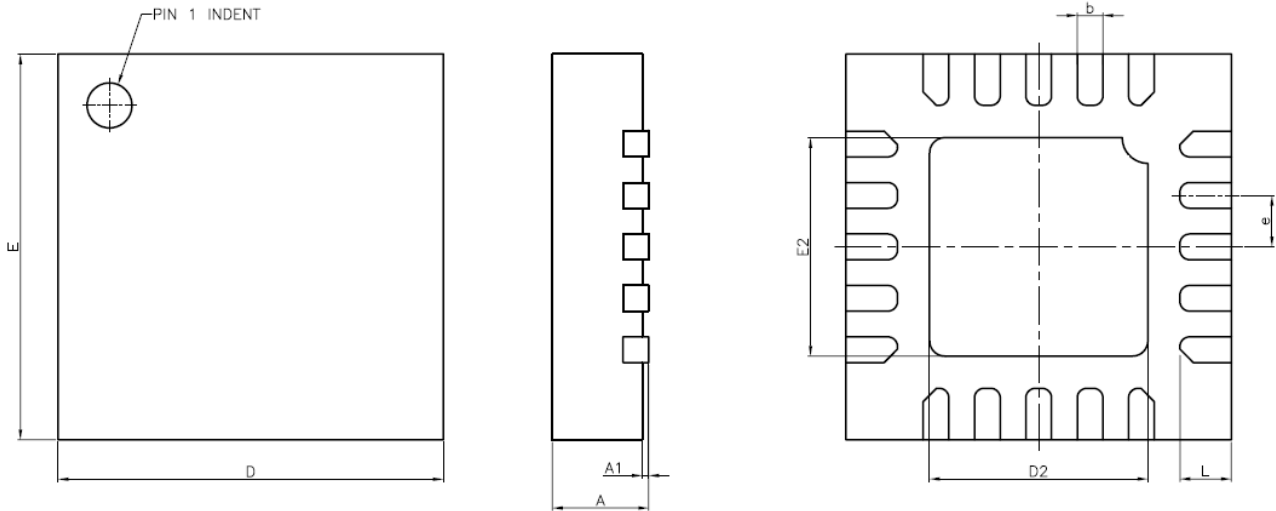

Note: Exposed pad outline drawing is for reference only.

SYMBOLS	MILLIMETERS			INCHES		
	MIN.	Normal	MAX.	MIN.	Normal	MAX.
A	0.70	0.75	0.80	0.028	0.030	0.031
A1	0.00	-	0.05	0.000	-	0.002
b	0.13	0.20	0.27	0.005	0.008	0.011
E	2.90	3.00	3.10	0.114	0.118	0.122
D	2.90	3.00	3.10	0.114	0.118	0.122
D2	1.45	1.70	1.75	0.057	0.067	0.069
E2	1.45	1.70	1.75	0.057	0.067	0.069
e	0.40 REF			0.016 REF		
L	0.30	0.40	0.50	0.012	0.016	0.020