

DESCRIPTION

The TCS3512 generates power supply rails for active-matrix organic light emitting diode (AMOLED) displays. It includes a step-up DC-DC and an inverting DC-DC converter making it suitable for battery operated products.

The step-up converter is a high-accuracy power-efficiency 250mA output regulator. It features an internal 0.5Ω N-MOSFET, 0.6Ω P-MOSFET and 1.4MHz operation frequency allowing the use of small inductor and capacitors. The integrated synchronous rectifier allows the true shutdown of the outputs. An internal digital soft-start function controls inrush currents. The step-up converter output can be externally set 4V to 8V.

The inverting converter is a high-accuracy 250mA regulator. It features an internal 0.4Ω N-MOSFET, 0.5Ω P-MOSFET and 1.4MHz operation frequency allowing the use of small inductor and capacitors. Its -6V to -1V output efficiency up to 80% at 150mA. An internal digital soft-start function controls inrush currents.

The TCS3512 is available in a small (3mm×3mm×0.6mm) 12 pin thin TDFN package and operates over the -40°C to +85°C temperature range.

FEATURES

- 2.5V to 4.5V Input Supply Range
- 1.4MHz Current Mode Step Up Regulator
 - External Programmable 4V~8V Output Voltage
 - Maximum 250mA Output
 - High Accuracy (+/- 1%)
 - Built-In 18V, 0.5Ω N-MOSFET
 - Built-In 18V, 0.6Ω P-MOSFET
- 1.4MHz Current Mode Inverting Regulator
 - Synchronous Rectifier
 - Cycle-by-Cycle Current Limit
 - More than 85% Efficiency at 150mA
 - Good Low-Duty Factor Operation
 - -6V to -1V
 - Maximum 250mA Output
 - High Accuracy (+/- 1%)
 - Built-In 18V, 0.5Ω P-MOSFET
 - Built-In 18V, 0.4Ω N-MOSFET
- Synchronous Rectifier
- Cycle-by-Cycle Current Limit
- More than 80% Efficiency at 150mA
- True Shutdown Mode for Dual Outputs
- Timer-Delayed Output Under-Voltage Shutdown for Dual Outputs
- Over Temperature Protection
- 12 Pin 3mm×3mm thin TDFN Package
- RoHS Compliant and 100% Lead(Pb)-Free Halogen-Free

APPLICATIONS

- OLED Displays
- Phone, DSC Display
- Automobile Navigation

Typical Application Circuit

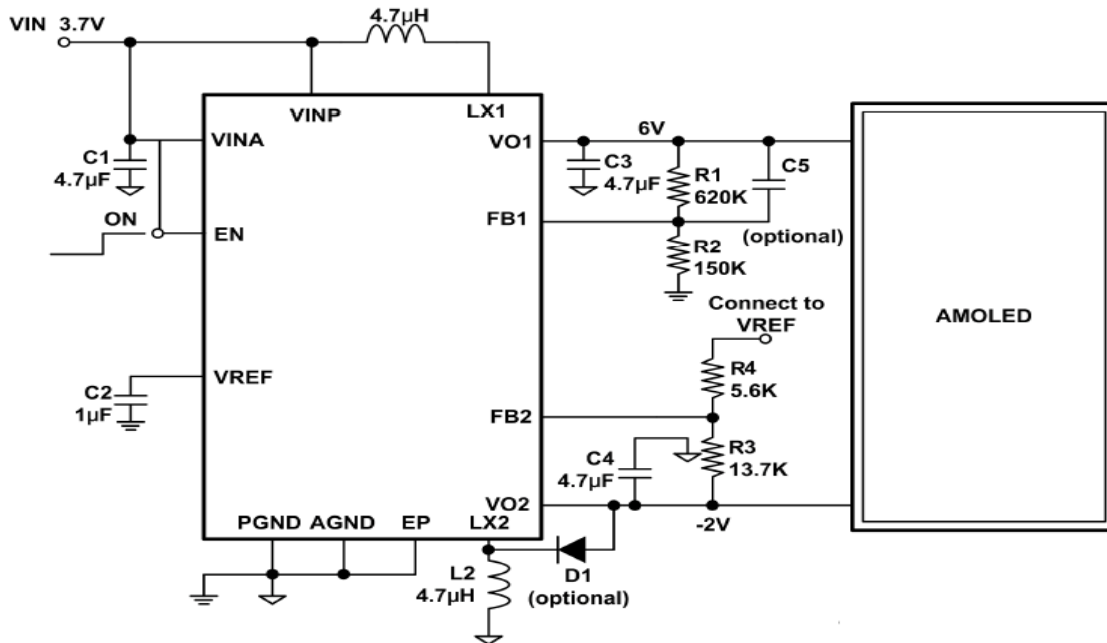

Vo1计算公式: $Vo1 = (R1+R2)*VFB1/R2$, $VFB1=1.209V$.

Vo2计算公式: $Vo2 = VFB2 - (VREF-VFB2)*R3/R4$, $VFB2=0.25V$, $VREF=1.209V$

Block Diagram

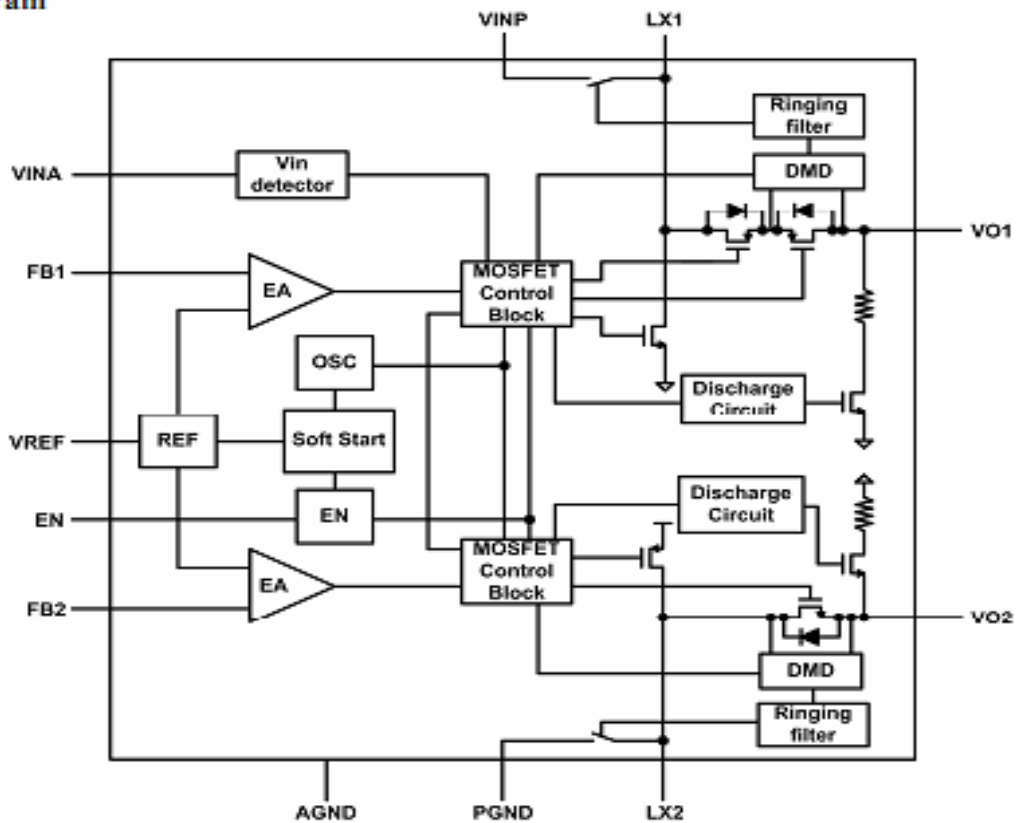
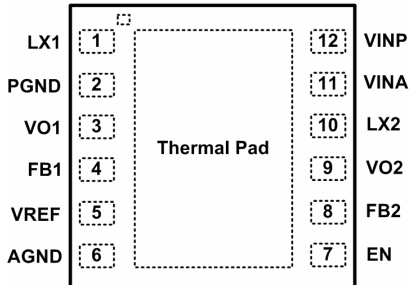

Figure2.

Pin Configurations

Package Type	Pin Configurations
TDFN-12	<p>(TOP VIEW)</p>  <p>The diagram shows a top view of the TDFN-12 package. It features 12 pins arranged in two columns of six. The left column pins are labeled LX1 (1), PGND (2), VO1 (3), FB1 (4), VREF (5), and AGND (6). The right column pins are labeled VINP (12), VINA (11), LX2 (10), VO2 (9), FB2 (8), and EN (7). A central rectangular area is labeled 'Thermal Pad'.</p>

Pin Description

PIN	TDFN-12	DESCRIPTION
LX1	1	Step-up regulator switch node
PGND	2	Power ground
VO1	3	Step-up regulator output voltage
FB1	4	Step-up regulator feedback input
VREF	5	Reference output. Bypass VREF to AGND with a 1 μ F ceramic capacitor.
AGND	6	Analog ground
EN	7	Active-high enable input
FB2	8	Inverting regulator feedback input
VO2	9	Inverting regulator output voltage
LX2	10	Inverting regulator switch node
VINA	11	Analog input supply voltage
VINP	12	Power input supply voltage

Ordering Information

Order Number	Package Type	Marking	Operating Temperature Range
TCS3512_DO	TDFN-12		-40 °C to +85°C

Absolute Maximum Ratings

■ DC Supply Voltage (V _{INA} , V _{INP})	-----	-0.3V to 6V
■ ENABLE Pin (EN)	-----	-0.3V to 6V
■ Inverting Regulator's Switching Current (ILX2)	-----	Internally limited
■ Inverting Regulator Switch Node (LX2)	-----	-6V to V _{INP} +0.3V
■ Inverting Regulator Output Voltage(VO2)	-----	-6V to GND +0.3V
■ Step-up Regulator Switch Node (VO1)	-----	8V
■ Step-up Regulator Output Voltage (LX1)	-----	8V
■ Step-up Regulator's Switching Current (ILX1)	-----	Internal Limited
■ Reference Output Voltage(VREF)	-----	-0.3V to 6V
■ Step-up Regulator Feedback Input (FB1)	-----	-0.3V to 6V
■ Inverting Regulator Feedback Input (FB2)	-----	-0.3V to 6V
■ Thermal Resistance θ _{JA} (TDFN-12)	-----	70°C /W
■ Storage Temperature (T _{ST})	-----	-60°C to +150°C
■ Maximum Junction Temperature	-----	150°C

Recommended Operating Conditions

■ Supply Voltage (VIN)	-----	2.5V to 4.5V
■ Operating Temperature (T _A)	-----	-40°C to +85°C

Electrical Characteristics

T_A=25°C, V_{INA}=V_{INP}=3.7V, I_{O1,2}=30mA, C_I=4.7μF, C_{O1,2}=4.7μF, C_{REF}=1μF, L1=4.7μH, L2=4.7μH, V_{EN}=V_{INA}=V_{INP}, V_{O1}=6V, V_{O2}=-2V unless otherwise specified.

Symbol	Parameter	Conditions	TCS3512			Unit
			Min.	Typ.	Max.	
General Section						
V _{IN}	Operating input voltage range	V _{O1} =4.6V, T _J =-40 to 85°C	2.5		4.5	V
UVLO_H	Under voltage lockout HIGH	V _{INA} rising, T _J =-40 to 85°C		2.40	2.50	V
UVLO_L	Under voltage lockout LOW	V _{INA} falling, T _J =-40 to 85°C	2.10	2.20		V
I _{V_I}	Input current	No load condition (I _{V_I} =I _{INP} +I _{INA}), V _{O1} =6V, V _{O2} =-2V		2		mA
I _S	Shutdown current	V _{EN} =GND, (I _S =I _{INP} +I _{INA})			5	μA
V _{ENH}	Enable high threshold	V _{INA} =2.5V to 4.5V, T _J =-40 to 85°C	1			V
V _{ENL}	Enable low threshold	V _{INA} =2.5V to 4.5V, T _J =-40 to 85°C			0.4	
I _{EN}	Enable input current	V _{EN} =V _I			1	μA
F _{SW}	Frequency	PWM mode, T _J =-40 to 85°C	1.1	1.4	1.7	MHz
D1 _{MAX}	Step-up maximum duty cycle			90		%
D2 _{MAX}	Inverting maximum duty cycle			90		%
η	Total system efficiency	I _{O1,2} =150mA, V _{O1} =6V, V _{O2} =-2V		84		%
V _{REF}	Voltage reference	I _{REF} =10μA	1.196	1.209	1.222	V
I _{REF}	Voltage reference current capability	At V _{REF} =V _{REF} -1.5%	100			μA
V _{O1}	Positive Output Setting Range	V _{INA} =2.5V to 4.5V, I _{O1} =5mA to 100mA	4		8	V

Electrical Characteristics (continued)

$T_A=25^{\circ}\text{C}$, $V_{\text{INA}}=V_{\text{INP}}=3.7\text{V}$, $I_{\text{O1,2}}=30\text{mA}$, $C_1=4.7\mu\text{F}$, $C_{\text{O1,2}}=4.7\mu\text{F}$, $C_{\text{REF}}=1\mu\text{F}$, $L_1=4.7\mu\text{H}$, $L_2=4.7\mu\text{H}$, $V_{\text{EN}}=V_{\text{INA}}=V_{\text{INP}}$, $V_{\text{O1}}=6\text{V}$, $V_{\text{O2}}=-2\text{V}$ unless otherwise specified

Symbol	Parameter	Conditions	TCS3512			Unit
			Min.	Typ.	Max.	
Step-up Converter Section						
ΔV_{O1SL}	Static line regulation ⁽¹⁾	$V_{\text{INA}}=2.5\text{V to }4.5\text{V}$, $I_{\text{O1}}=5\text{mA}$, I_{O2} no load; $T_J=-40$ to 85°C		0.5		%
		$V_{\text{INA}}=2.5\text{V to }4.5\text{V}$, $I_{\text{O1}}=100\text{mA}$, I_{O2} no load; $T_J=-40$ to 85°C		1		
ΔV_{O1LT}	Line transient	$V_{\text{INA}}=3.5\text{V to }3.0\text{V}$, $I_{\text{O1}}=100\text{mA}$, $T_J=-40$ to 85°C , $T_R=T_F=50\mu\text{s}$ output voltage variation with respect to nominal V_{O1}		-30		mV
ΔV_{O1}	Static load regulation ⁽²⁾	$I_{\text{O1}}=5$ to 100mA , I_{O2} no load, $V_{\text{INA}}=2.5\text{V}$; $T_J=-40$ to 85°C		+1		%
		$I_{\text{O1}}=5$ to 100mA , I_{O2} no load, $V_{\text{INA}}=4.5\text{V}$; $T_J=-40$ to 85°C		+0.5		
ΔV_{O1t}	Load transient regulation	$I_{\text{O1}}=3$ to 30mA and $I_{\text{O1}}=30$ to 3mA , $T_R=T_F=30\mu\text{s}$, output voltage variation with respect to nominal V_{O1}		± 50		mV
		$I_{\text{O1}}=10$ to 100mA and $I_{\text{O1}}=100$ to 10mA , $T_R=T_F=30\mu\text{s}$, output voltage variation with respect to nominal V_{O1}		± 100		
I_{O1}	Maximum Step-up output current	$V_1=2.9\text{V to }5.5\text{V}$	150			mA
I_{L1MAX}	I_{peak} current	V_{O1} below 10% of nominal value	1			A
R_{DSONP1}				0.6	1.0	Ω
R_{DSONN1}				0.5	0.8	Ω
Inverting Converter Section						
V_{O2}	Negative Output Voltage Setting Range		-6		-1	V
ΔV_{O2SL}	Static line regulation ⁽³⁾	$V_{\text{INA}}=2.5\text{V to }4.5\text{V}$, $I_{\text{O2}}=5\text{mA}$, I_{O1} no load; $T_J=-40$ to 85°C		+0.5		%
		$V_{\text{INA}}=2.5\text{V to }4.5\text{V}$, $I_{\text{O2}}=100\text{mA}$, I_{O1} no load; $T_J=-40$ to 85°C		+1		
ΔV_{O2LT}	Line transient	$V_{\text{INA}}=3.5\text{V to }3.0\text{V}$, $I_{\text{O2}}=100\text{mA}$, $T_J=-40$ to 85°C , $T_R=T_F=50\mu\text{s}$ output voltage variation with respect to nominal V_{O2}		+20		mV
ΔV_{O2}	Static load regulation ⁽⁴⁾	$I_{\text{O2}}=5$ to 100mA , I_{O1} no load, $V_{\text{INA}}=2.5\text{V}$; $T_J=-40$ to 85°C		+2		%
		$I_{\text{O2}}=5$ to 100mA , I_{O1} no load, $V_{\text{INA}}=4.5\text{V}$; $T_J=-40$ to 85°C		+1.5		
ΔV_{O2t}	Load transient regulation	$I_{\text{O2}}=3$ to 30mA and $I_{\text{O2}}=30$ to 3mA , $T_R=T_F=30\mu\text{s}$, output voltage variation with respect to nominal V_{O2}		± 20	± 80	mV
ΔV_{O2e}	Load transient regulation HC	$I_{\text{O2}}=10$ to 100mA and $I_{\text{O2}}=100$ to 10mA , $T_R=T_F=30\mu\text{s}$		± 30	± 50	mV
I_{O2s}	Maximum inverting output current	$V_{\text{INA}}=2.5\text{V to }2.9\text{V}$			-120	mA

Electrical Characteristics (continued)

$T_A=25^{\circ}\text{C}$, $V_{INA}=V_{INP}=3.7\text{V}$, $I_{O1,2}=30\text{mA}$, $C_I=4.7\mu\text{F}$, $C_{O1,2}=4.7\mu\text{F}$, $C_{REF}=1\mu\text{F}$, $L1=4.7\mu\text{H}$, $L2=4.7\mu\text{H}$, $V_{EN}=V_{INA}=V_{INP}$, $V_{O1}=6\text{V}$, $V_{O2}=-2\text{V}$ unless otherwise specified

Symbol	Parameter	Conditions	TCS3512			Unit
			Min.	Typ.	Max.	
Inverting Converter Section						
I_{O2}	Maximum inverting output current	$V_{INA}=2.9\text{V}$ to 4.5V			-150	mA
I_{L2MAX}	I_{peak} current	V_{O2} below 10% of value		-1.2	-1.1	A
R_{DSONP2}				0.5	0.8	Ω
R_{DSONN2}				0.4	0.7	Ω
Thermal shutdown						
OTP	Over temperature protection			150		$^{\circ}\text{C}$
OTP_{HYST}	Over temperature protection hysteresis			20		$^{\circ}\text{C}$
Discharge resistor						
R_{DIS}	Discharge resistor value			600		Ω
T_{DIS}	Discharge time			6		ms

- $[(V_{O1MAX} - V_{O1MIX}) / (V_{O1} \text{ at } 25^{\circ}\text{C} \text{ and } V_{INA}=2.5\text{V})] \times 100$
- $[(V_{O1MAX} - V_{O1MIX}) / (V_{O1} \text{ at } 25^{\circ}\text{C} \text{ and } I_{O1}=5\text{mA})] \times 100$
- $[(V_{O2MAX} - V_{O2MIX}) / (V_{O2} \text{ at } 25^{\circ}\text{C} \text{ and } V_{INA}=2.5\text{V})] \times 100$
- $[(V_{O2MAX} - V_{O2MIX}) / (V_{O2} \text{ at } 25^{\circ}\text{C} \text{ and } I_{O2}=5\text{mA})] \times 100$

Typical Operating Characteristics

$T_A=25^{\circ}\text{C}$, $V_{\text{INA}}=V_{\text{INP}}=3.7\text{V}$, $C_1=4.7\mu\text{F}$, $C_{\text{O1,2}}=4.7\mu\text{F}$, $C_{\text{REF}}=1\mu\text{F}$, $L_1=4.7\mu\text{H}$, $L_2=4.7\mu\text{H}$, $V_{\text{EN}}=V_{\text{INA}}=V_{\text{INP}}$, $V_{\text{O1}}=6\text{V}$, $V_{\text{O2}}=-2\text{V}$

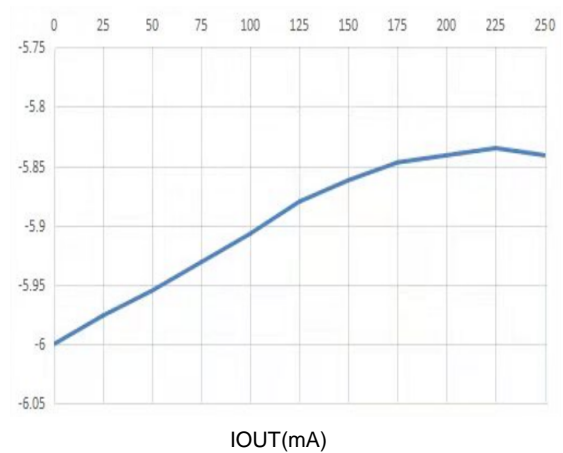
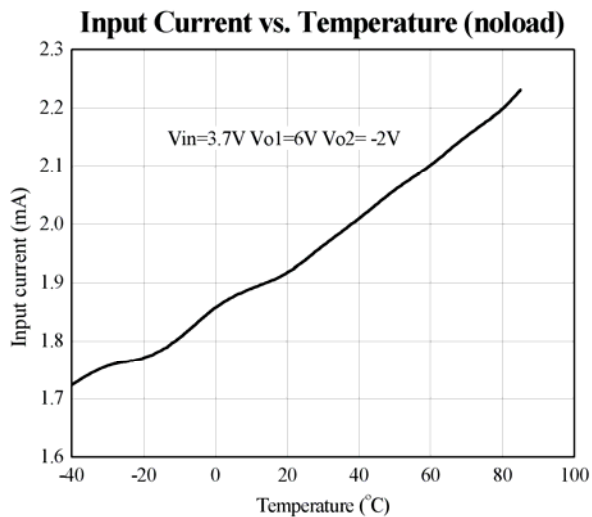
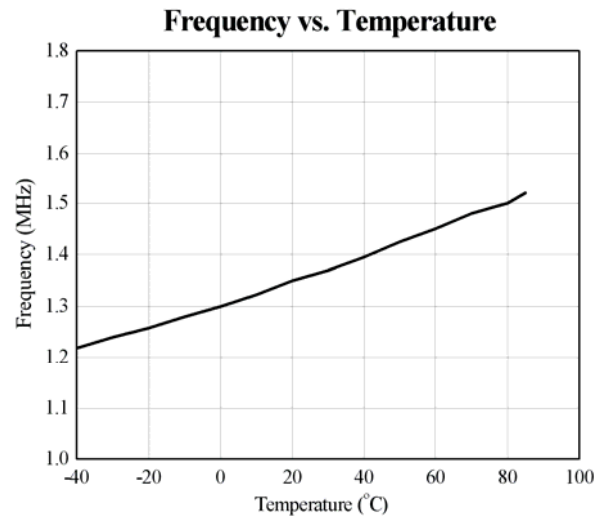
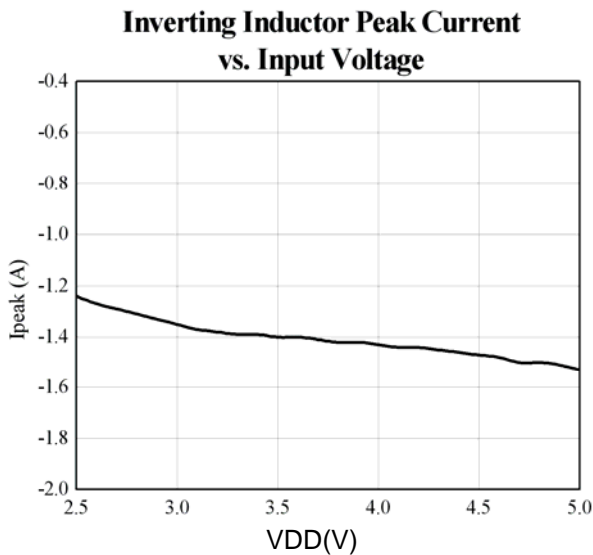
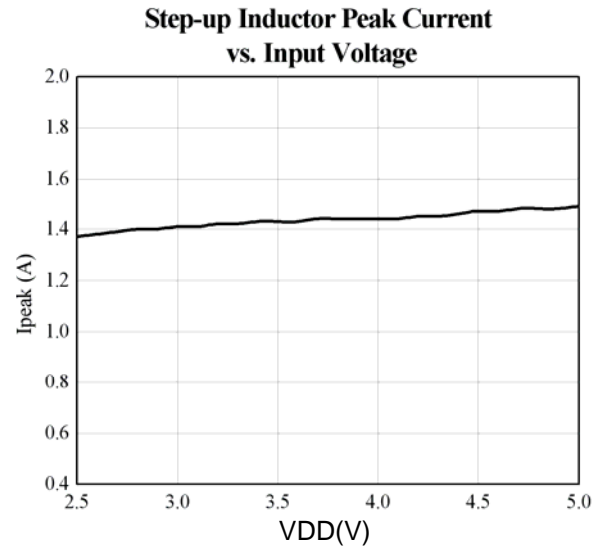
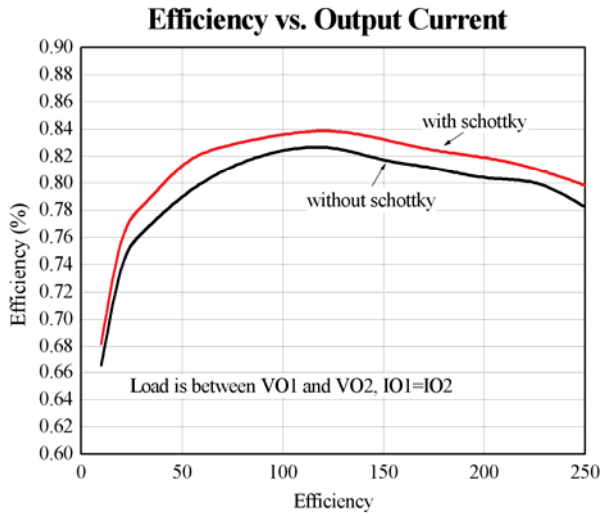

Typical Operating Characteristics (continued)

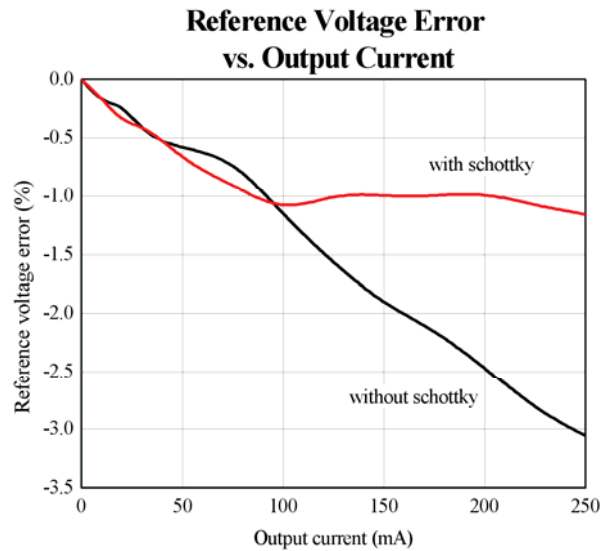
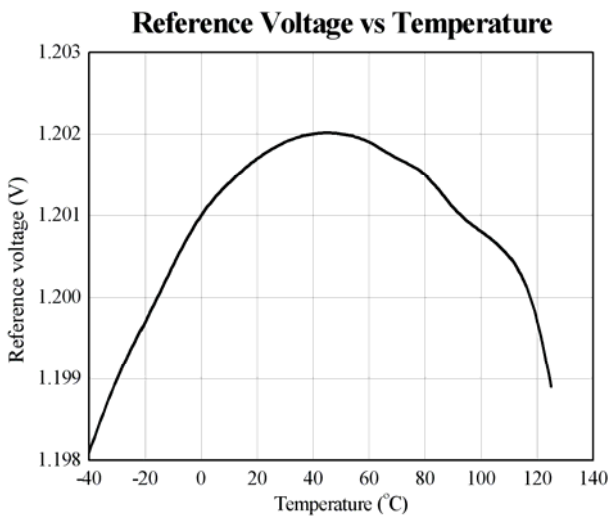
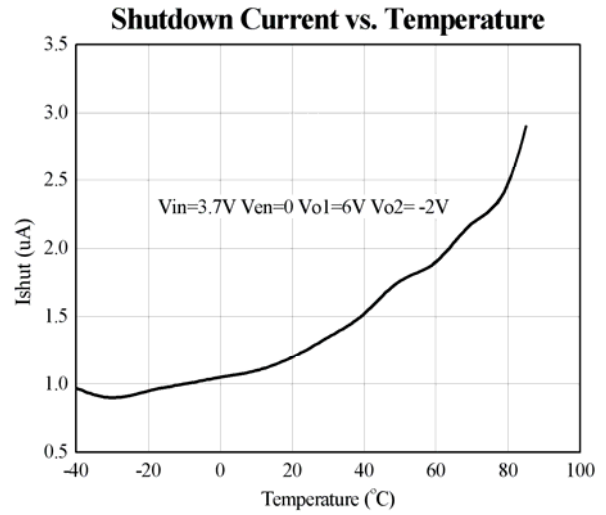
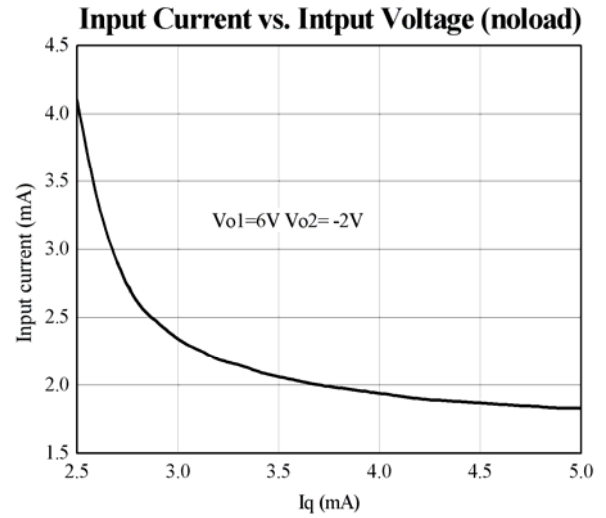
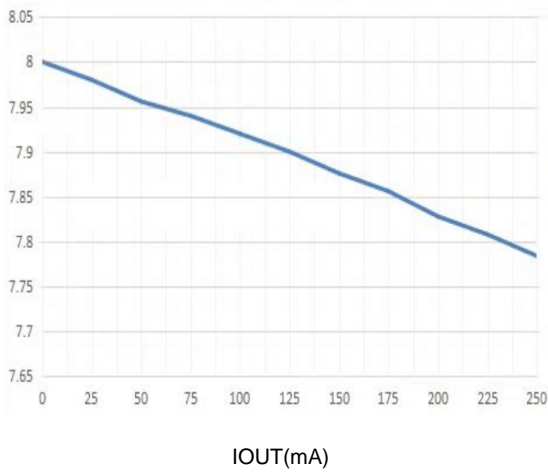

Typical Operating Characteristics (continued)

Startup 100mA Load

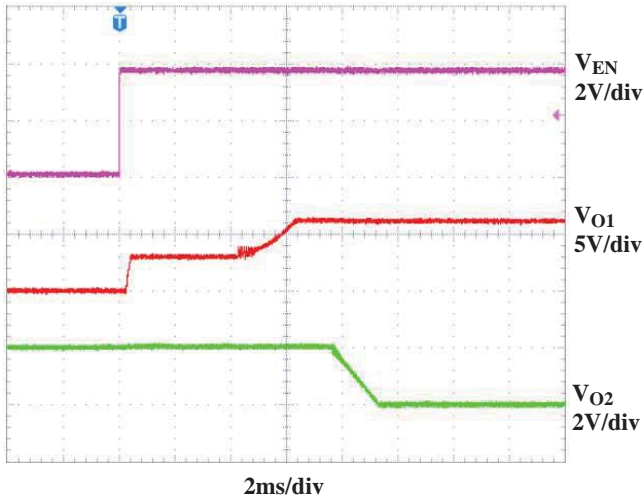

Fast Discharge

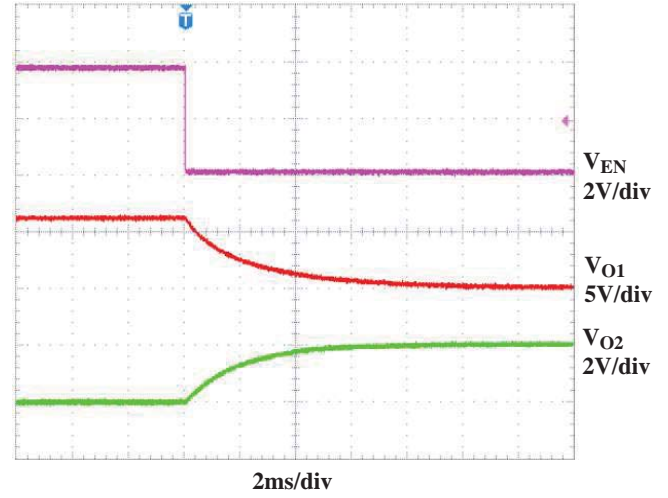

Step-up DCM Mode (30mA Load)

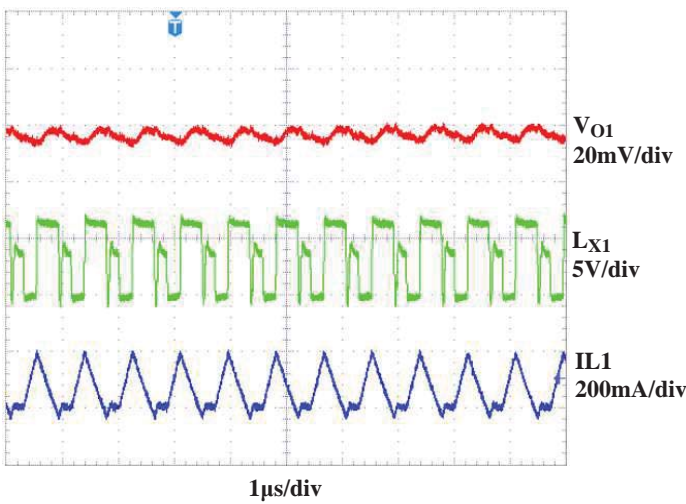

Step-up CCM Mode (100mA Load)

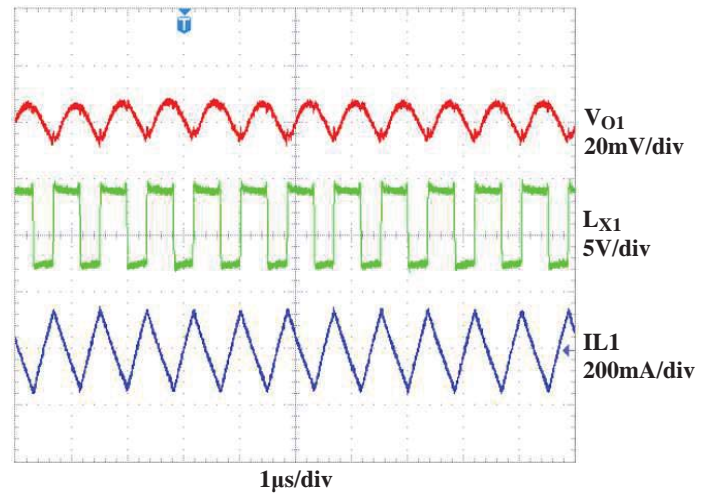

Inverting DCM Mode (30mA Load)

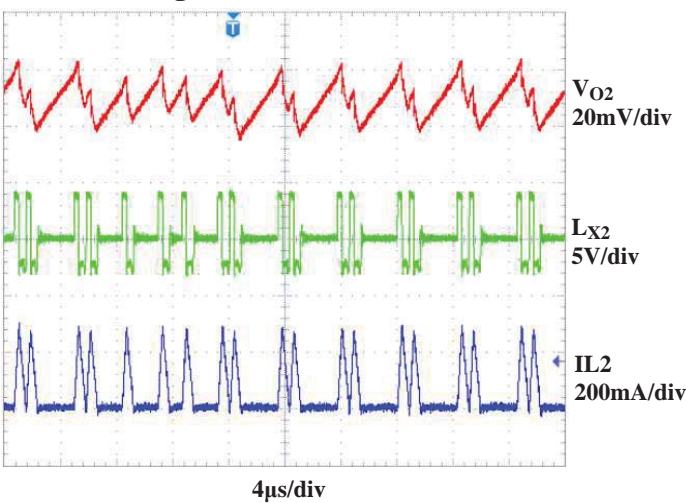

Inverting CCM Mode (100mA Load)

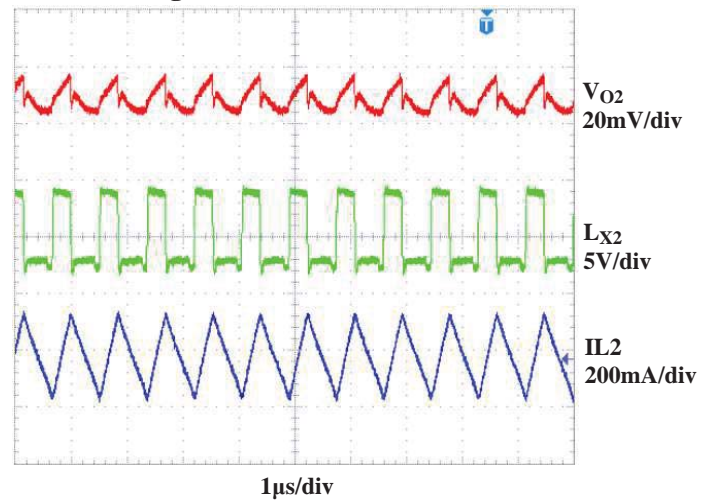

Typical Operating Characteristics (continued)

Step-up Line Transient Response (3 to 3.5V)

$I_{O1}=100\text{mA}$ $I_{O2}=0$

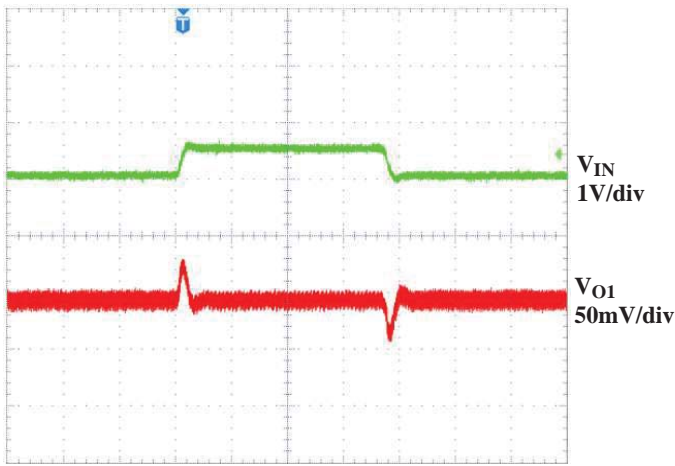

200µs /div

Inverting Line Transient Response (3 to 3.5V)

$I_{O1}=0$ $I_{O2}=100\text{mA}$

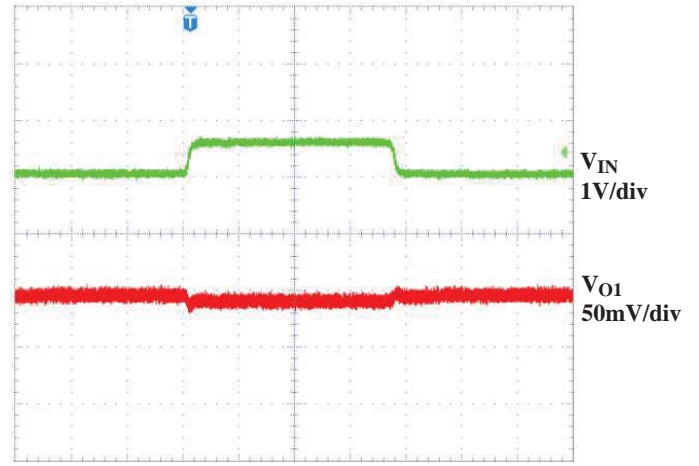

200µs /div

Step-up Load Transient Response

$I_{O1}=3$ to 30mA $I_{O2}=0$

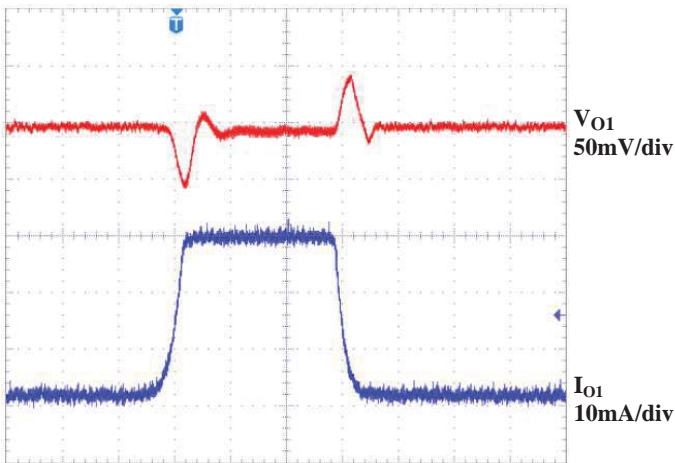

100µs/div

Step-up Load Transient Response

$I_{O1}=10$ to 100mA $I_{O2}=0$

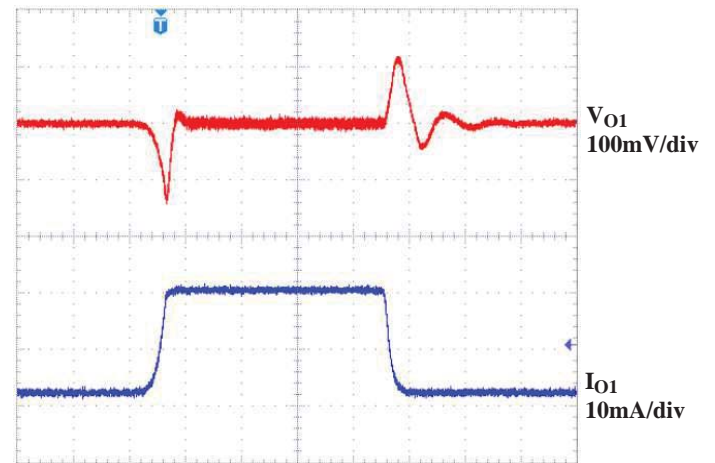

100µs/div

Inverting Load Transient Response

$I_{O1}=0$ $I_{O2}=3$ to 30mA

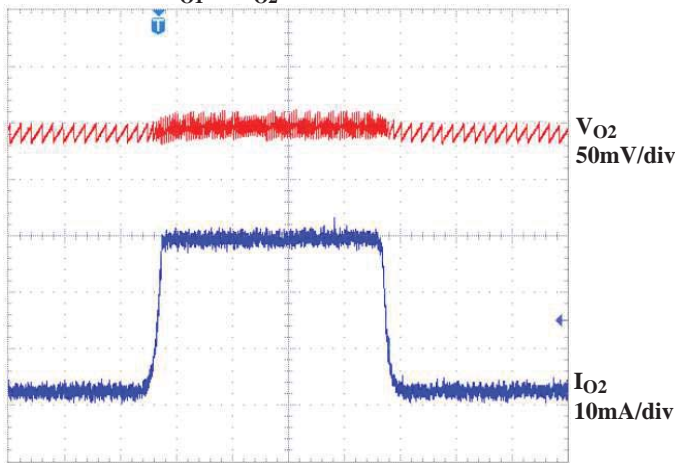

100µs/div

Inverting Load Transient Response

$I_{O1}=0$ $I_{O2}=10$ to 100mA

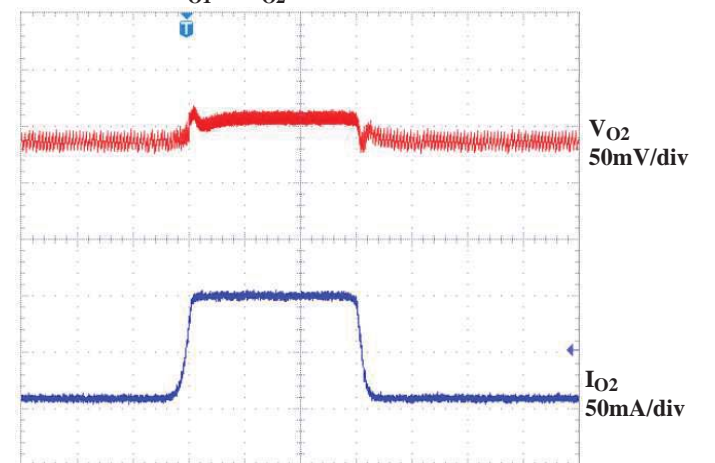

100µs/div

Detailed Description

The TCS3512 includes two current-mode 1.4MHz synchronous regulators for AMOLED displays. The step-up regulator output is adjustable from 4V to 8V and the inverting regulator output is adjustable from -6V to -1V both through the external resistors. Both regulators provide an output current of 250mA. The integrated high-efficiency MOSFET and the built-in digital soft-start function reduce the number of external components for a very compact application circuit while controlling inrush currents.

Step-Up Regulator

The step-up regulator is a constant-frequency current mode type. It operates at a 1.4MHz switching frequency to allow the use of tiny inductors. The regulator controls the output voltage and the power delivered to the output by modulating the duty cycle (D) of the internal power MOSFET in each switching cycle. An error amplifier compares the signal FB1 with an internal reference voltage and changes its output internal compensation node COMP1 to set the peak inductor current. As the load varies the error amplifier sources or sinks current to the compensation node COMP1 accordingly to produce the inductor peak current necessary to service the load. To maintain stability at high duty cycles, a slope-compensation signal is summed with the current-sense signal.

The converter operates in skip mode at light loads condition and includes an anti-ringing switch that turns on when the synchronous rectifier turns off at zero or negative current to control LX1 ringing.

Inverting Converter

The inverting converter is also a constant-frequency (1.4MHz) current-mode type and includes synchronous rectifier. The inverter operates in skip mode at light loads and includes an anti-ringing switch that turns on when the synchronous rectifier turns off at zero or negative current. The switch prevents ringing in the inductor in discontinuous conduction and the resulting RF noise.

The inverting converter operates similarly to the step-up converter, except that the main switch is a p-channel MOSFET between LX2 and VIN. Energy is stored in the inductor during the switch on-time and the continuous inductor current pulls current from the output to ground when the flip-flop resets, the main switch turns off, and the synchronous rectifier turns on.

Undervoltage Lockout (UVLO)

The UVLO circuit compares the input voltage at VIN with the UVLO threshold (2.40V rising, 2.20V falling, typ) to ensure the input voltage is high enough for reliable operation. The wide 200mV (typ) hysteresis prevents supply transients from causing a restart. The startup procedure begins when input voltage exceeds the UVLO rising threshold and EN goes above its logic-high threshold. During normal operation, if the input voltage

falls below the UVLO falling threshold, the controller turns off the regulators.

Thermal Protection

The TCS3512 includes a thermal-protection circuit. Thermal-overload protection prevents excessive power dissipation from overheating the device. When the junction temperature exceeds +150°C, a thermal sensor immediately activates the fault protection, which shuts down the two outputs except the reference, allowing the device to cool down. Once the device cools down by approximately 20°C, cycle the input voltage (below the UVLO falling threshold) to clear the fault latch and reactivate the device. For continuous operation, do not exceed the absolute maximum junction temperature rating of +150°C.

Design Procedure

Inductor Selections

The minimum inductance value, peak current rating, and series resistance are factors to consider when selecting the inductor. These factors influence the converter's efficiency, maximum output load capability transient-response time, and output voltage ripple. Size and cost are also important factors to consider.

The maximum output current, input voltage, output voltage, and switching frequency determine the inductor value. Very high inductance values minimize the current ripple, and therefore reduce the peak current, which decreases core losses in the inductor and conduction losses in the entire power path. However, large inductor values also require more energy storage and more turns of wire, which increase size and can increase conduction losses in the inductor. Low inductance values decrease the size, but increase the current ripple and peak current. Finding the best inductor involves choosing the best compromise between circuit efficiency, inductor size, and cost.

The equations used here include a constant, LIR, which is the ratio of the inductor peak-to-peak ripple current to the average DC inductor current at the full load current. The best trade-off between inductor size and circuit efficiency for step-up and inverting regulators generally has an LIR between 0.3 and 0.5. However, depending on the AC characteristics of the inductor core material and ratio of inductor resistance to other power-path resistances, the best LIR can shift up or down. If the inductor resistance is relatively high, more current ripple can be accepted to reduce the number of turns required and increase the wire diameter. If the inductor resistance is relatively low, increasing inductance to lower the peak current can decrease losses throughout the power path. If extremely thin high-resistance inductors are used, the best LIR can increase to between 0.5 and 1.0.

Once a physical inductor is chosen, higher and lower values of the inductor should be evaluated for efficiency improvements in typical operating regions.

Calculate the required inductance, the maximum DC current, the inductor ripple current, and the peak inductor current using the equations below to choose an inductor value from an appropriate inductor family. The inductor's saturation current rating and the LX1 and LX2 current limits should exceed the peak currents calculated above. The inductor's DC current rating should exceed the maximum expected DC current. For good efficiency, choose an inductor with less than 0.5Ω series resistance.

Step-Up Converter Inductor L₁

Use the following procedure to choose the inductor for the step-up converter. An example is provided below using typical operating conditions of:

Calculate the required inductance:

$$L_1 = \left(\frac{V_{IN(TYP)}}{V_{O1}} \right)^2 \times \left(\frac{V_{O1} - V_{IN(TYP)}}{I_{O1(MAX1)} \times f_{SW}} \right) \times \left(\frac{\eta_1(TYP)}{LIR} \right)$$

The step up converter is a current mode PWM converter operating in both discontinuous conduction mode (DCM) at light load and continuous mode (CCM). In continuous current mode, current flows continuously in the inductor during the entire switching cycle in steady state operation. The voltage conversion ratio in continuous current mode is given by:

$$\frac{V_{O1}}{V_{IN}} = \frac{1}{1-D}$$

Where D is the duty cycle of the switching MOSFET.

Figure 2 shows the block diagram of the boost regulator. It uses a error amplifier architecture consisting of gm stages for voltage feedback. A comparator looks at the peak inductor current cycle by cycle and terminates the PWM cycle if the current limit is reached.

An external resistor divider is required to divide the output voltage down to the nominal reference voltage. Current drawn by the resistor network should be limited to maintain the overall converter efficiency. The maximum value of the resistor network is limited by the feedback input bias current and the potential for noise being coupled into the feedback pin. The boost converter output voltage is determined by the following equation:

$$V_{O1} = \frac{R1 + R2}{R2} \times V_{FB1}$$

The current through the MOSFET is limited to 1.4 APEAK.

This restricts the maximum output current (average) based on the following equation:

$$I_{OMAX} = \left(I_{LMT} - \frac{\Delta I_L}{2} \right) \times \frac{V_{IN}}{V_{O1}}$$

Where ΔI_L is peak to peak inductor ripple current, and is set by:

$$\Delta I_L = \frac{V_{IN}}{L} \times \frac{D}{f_S}$$

Choose L₁ = 4.7μH since actual inductance of these small inductors is much less at significant current.

Calculate the maximum DC current in the inductor and select an inductor whose DC current rating is greater than the maximum DC current calculated:

$$I_{L1(DC_MAX)} = \frac{I_{O1(MAX2)} \times V_{O1}}{V_{IN(MIN)} \times \eta_{1MIN}}$$

Calculate the peak amplitude of the inductor current and choose an inductor with a saturation current rating greater than the peak inductor current calculated. Also, verify that the peak inductor current amplitude is below the minimum current rating of LX1. Use the formulas below to calculate the inductor current ripple and peak inductor current:

$$\Delta I_{L1_RIPPLE} = \frac{V_{IN(MIN)} \times (V_{O1} - V_{IN(MIN)})}{L_1 \times V_{O1} \times f_{SW}}$$

$$I_{L1(PEAK)} = I_{L1(DC_MAX)} + \frac{\Delta I_{L1_RIPPLE}}{2}$$

Inverting Converter Inductor L₂

Use the following procedure to choose the inductor for the inverting converter. An example is provided below using typical operating conditions of:

Calculate the required inductance:

$$L_2 = \left(\frac{V_{IN(TYP)}}{V_{IN(TYP)} + |V_{O2}|} \right)^2 \times \left(\frac{|V_{O2}| \times \eta_{2TYP}}{f_{SW} \times I_{O2(MAX1)} \times LIR} \right)$$

Choose L₂ = 4.7FH since inductance of these small inductors decreases with high current.

Calculate the maximum DC current in the inductor to select an inductor whose DC current rating is greater than the maximum DC current calculated:

$$I_{L2(DC_MAX)} = I_{O2(MAX2)} \times \left(\frac{|V_{O2}| + V_{IN(MIN)}}{\eta_{2MIN} \times V_{IN(MIN)}} \right)$$

Calculate the peak amplitude of the inductor current to choose an inductor with a saturation current rating less than the peak inductor current calculated. Also, with this result, verify that the peak inductor current amplitude is below the minimum current rating of LX2. Formulas to calculate the inductor current ripple and peak inductor current follow:

$$\Delta I_{L2_RIPPLE} = \left(\frac{V_{IN(MIN)}}{L_2 \times f_{SW}} \right) \times \left(\frac{|V_{O2}|}{V_{IN(MIN)} + |V_{O2}|} \right)$$

$$I_{L2(PEAK)} = I_{L2(DC_MAX)} + \frac{\Delta I_{L2_RIPPLE}}{2}$$

The total output voltage ripple has two components: the capacitive ripple caused by the charging and discharging of the output capacitance, and the ohmic ripple due to the capacitor's equivalent series resistance (ESR):

For the step-up converter:

$$V_{O1_RIPPLE} = V_{O1_RIPPLE(C)} + V_{O1_RIPPLE(ESR)}$$

$$V_{O1_RIPPLE(C)} \approx \left(\frac{I_{O1}}{C_{O1} \times f_{SW}} \right) \times \left(\frac{V_{O1} - V_{IN}}{V_{O1}} \right)$$

and:

$$V_{O1_RIPPLE(ESR)} \approx I_{L1(PEAK)} \times R_{ESR_CO1}$$

where:

C_{O1} is the step-up converter's output capacitance.
 $I_{L1(PEAK)}$ is the step-up converter's peak inductor current from the inductor selection.

R_{ESR_CO1} is the capacitor's ESR.

For the inverting converter:

$$V_{O2_RIPPLE} = V_{O2_RIPPLE(C)} + V_{O2_RIPPLE(ESR)}$$

$$V_{O2_RIPPLE(C)} \approx \left(\frac{I_{O2}}{C_{O2} \times f_{SW}} \right) \times \left(\frac{|V_{O2}|}{V_{IN} + |V_{O2}|} \right)$$

and:

$$V_{O2_RIPPLE(ESR)} \approx I_{L2(PEAK)} \times R_{ESR_CO2}$$

where:

C_{O2} is the inverting converter's output capacitance.
 $I_{L2(PEAK)}$ is the inverting converter's peak inductor current from the inductor selection.

R_{ESR_CO2} is the capacitor's ESR.

For ceramic capacitors, the output-voltage ripple is typically dominated by the capacitive term. The voltage rating and temperature characteristics of the output capacitor must also be considered.

Input Capacitor Selection

The input capacitor reduces the current peaks drawn from the input supply and reduces noise injection into the IC. Two 4.7 μ F ceramic capacitors are used.

PCB Layout and Grounding

Careful PCB layout is important for proper operation. Use the following guidelines for good PCB layout:

- 1) Place the VIN pin and VREF pin bypass capacitors as close as possible to the device.
- 2) Keep the traces of the main current paths as short and wide as possible.
- 3) Connect the output capacitors of VO1 and VO2 as close as possible to their respective pins.
- 4) Create a power ground plane (PGND) so the other end of these capacitors and the PGND pin can connect to this plane directly.
- 5) Connect feedback network behind the output capacitors. Keep the loop area small. Place the feedback components near the device.
- 6) LX node is with high frequency voltage swing and should be kept at small area. Keep analog components away from the LX node to prevent stray capacitive noise pickup.
- 7) Minimize the length and maximize the width of the traces between the output capacitors and the load for best transient responses.
- 8) Avoid using vias in the high-current paths. If vias are unavoidable, use many vias in parallel to reduce resistance and inductance.

Packaging Information

TDFN-12

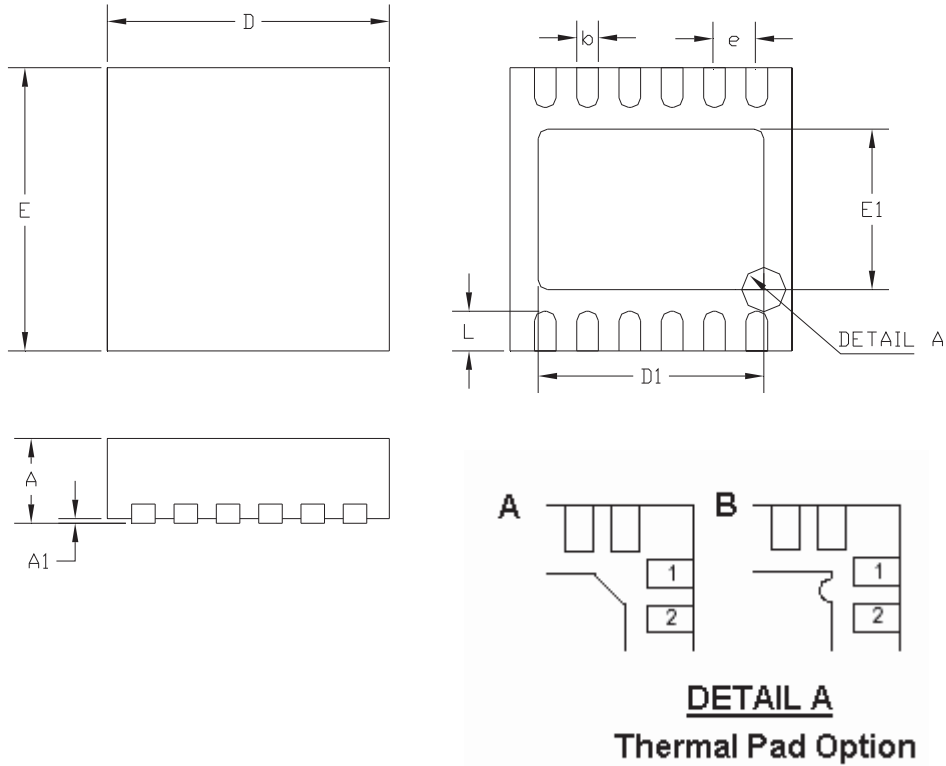

SYMBOLS	MILLIMETERS		INCHES	
	MIN.	MAX.	MIN.	MAX.
A	0.70	0.80	0.028	0.031
A1	0.00	0.05	0.000	0.002
b	0.18	0.30	0.007	0.012
E	2.90	3.10	0.114	0.122
D	2.90	3.10	0.114	0.122
D1	2.40		0.094	
E1	1.70		0.067	
e	0.45		0.018	
L	0.30	0.50	0.012	0.020