



MIL-DTL-26500

Features and Application

MS2426*/AE66*

Features and Application

MIL-DTL-26500 family offers connectors with bayonet coupling as well as threaded coupling. These connectors are intermateable with correspondingly coupled MIL-DTL-83723 Series III connectors (except shell size 8, threaded coupling only).

AE66 connectors are widely used on commercial, military and aerospace systems requiring general-purpose, miniature cylindrical bayonet or threaded coupling connectors.

This family (bayonet as well as threaded) of connectors is offered in wall mount receptacles, jam nut mounted receptacles which incorporate O'ring seals, designed for rear panel "D" hole mounting, and straight plugs.

Twenty-one insert arrangements per MIL-STD-1554 are tooled and qualified to MIL-DTL-26500, utilizing 3 to 57 M39029 contacts. Contacts come in sizes 20, 16 and 12, terminating wire sizes from 24 to 12 gauge.

These connectors are only available in aluminum shells with anodic plating to the MS number. In addition, we offer connectors with passivated stainless steel shells to commercial callouts only.

Insert Polarization

Alternate insert positions documented in the original specification, positions 1 through 5, are still available (except in shell size 8), but are not approved for new design. These alternate insert clocking positions aid in mating of adjacent connectors having identical insert arrangement.

Shell Polarization – Alternate key/keyway positions prevent cross mating of adjacent connectors having same insert arrangement.

Connector Sealing – A pressure seal at the connector interface is accomplished through the aid of a coupling device which compresses the front resilient insulators and thus offers a seal around each contact preventing the passage of moisture through the contact cavity. Rear resilient insulators are designed with a triple wire seal in each cavity to offer positive sealing and prevent wicking of moisture through the connector without the use of external clamping devices or adapters. In addition, a dynamic O'ring seal in the receptacles engages the front of the plug shell when connectors are mated and offers yet another barrier to moisture and contaminants.

Superior Contact Stability - Front release crimp contact system features a beryllium-copper retaining clip completely encased in a tough dielectric wafer, thus protecting the clip tines from damage.

Closed Entry Socket Contacts

Closed-entry socket contacts facilitate positive mating.



26500

MIL-DTL-26500
Performance Specifications
MS2426*/AE66*



Performance Specifications

Operating Temperature Range

Class R: -55°C to +200°C (-67°F to +392°F)
 Class E*: -55°C to +200°C (-67°F to +392°F)

Material and Finish Data (Class)

R – aluminum shell, black anodized finish
 E* – stainless steel shell, passivated

Corrosion Resistance

Classes R and E* withstand 48-hour salt spray.

Environmental Seal

Wired, mated connectors shall meet the altitude-immersion test specified by MIL-DTL-26500.

Fluid Resistance

Unmated connectors resist specified immersions in MIL-PRF-5606 (hydraulic fluid), MIL-PRF-23699 (lubricating oil), MIL-PRF-7808 (lubricating oil), MIL-DTL-5624 (JP-5) and glycol.

Durability

Bayonet Coupling – 500 cycles
 Threaded Coupling – 200 cycles

Shock and Vibration Requirements

Wired, mated connectors shall not be damaged, coupling ring shall not loosen, and there shall be no interruption of electrical continuity longer than one microsecond when subjected to the following:

Shock

Mated connectors withstand a pulse of approximate half sine wave of 100 G magnitude with duration of 6 milliseconds applied in each of the three major axes.

Vibration

Mated connectors withstand the following vibration levels:

- Vibration per EIA-364, test procedure 28 conducted at a low temperature ambient of -55°C (-67°F) and high ambient of +200°C (392°F).

Shell-to-Shell Conductivity

- Class R is non-conductive.
- Maximum potential drop shall not exceed 200 millivolts for class E*.

Voltage Rating

Service Rating	Suggested Operating Voltage**		Test Voltage	Test Voltage	Test Voltage	Test Voltage
	(Sea Level)		Sea Level	50,000 Ft.	70,000 Ft.	110,000 Ft.
	AC (RMS)	DC	V RMS	V RMS	V RMS	V RMS
I	600	850	1500	450	275	200

* Class E only available to commercial callouts. Consult factory for drawings. Pages 153 thru 158 apply to class R only.

** To be used by designer only as a guide.



MIL-DTL-26500

**Part Number Development
Bayonet & Threaded Coupling**

Part Number Development

Mil. Prefix	MS	24266	R	12	T	12	P	N	
Aero Prefix	AE	666	R	12	T	12	P	N	-340
Shell type									
24264 = Wall mount receptacle = 664 (Aero p/n)									
24265 = Jam nut receptacle = 665 (Aero p/n)									
24266 = Straight plug = 666 (Aero p/n)									
Class (Material and Finish)									
R = Aluminum shell, black anodized finish									
E* = Stainless steel shell, passivated									
Shell Size (SS)									
8, 10, 12, 14, 16, 18, 20, 22 or 24									
Coupling Mechanism									
B = Bayonet Coupling									
T = Threaded Coupling									
Insert Arrangement									
See pages 164									
Contact Style									
P = Pin									
S = Socket									
Polarization (Keying)									
N = Normal									
6, 7, 8, 9 or Y (Alternate keyed positions, Y is not available in SS 8)									
1, 2, 3, 4 or 5 (Locked insert polarizations within normally keyed shell, not approved for new design, n/a in SS 8)									
Modification (applies to Aero part numbers only)									
01 = Less contacts (is not marked on the part)									
341 = Connector kitted with MS27291-XX straight clamp									
Consult factory for other modifications									

* Class E only available to commercial callouts. Consult factory for drawings. Pages 153 thru 158 apply to class R only.

Note 1: Each connector is furnished with contacts unless ordered less contacts (L/C) as follows: Two spare contacts for each size contact utilized and at least 15% of the number of contacts but no less than three sealing plugs are provided. No insertion/removal tools are provided. No spares are required for shielded contacts.

Note 2: Proper part number marking has no “0” in front of single digit shell size (8), and no “0” in front of single digit layouts. Example: MS24264R8B3SN and MS24264R18B8P6. Please note that in this series “N” for normal is included in part number marking.

26500

MS24264RB**
Wall Mounting Receptacle
AE664RB**



Bayonet Coupling, Crimp Removable, Front Release

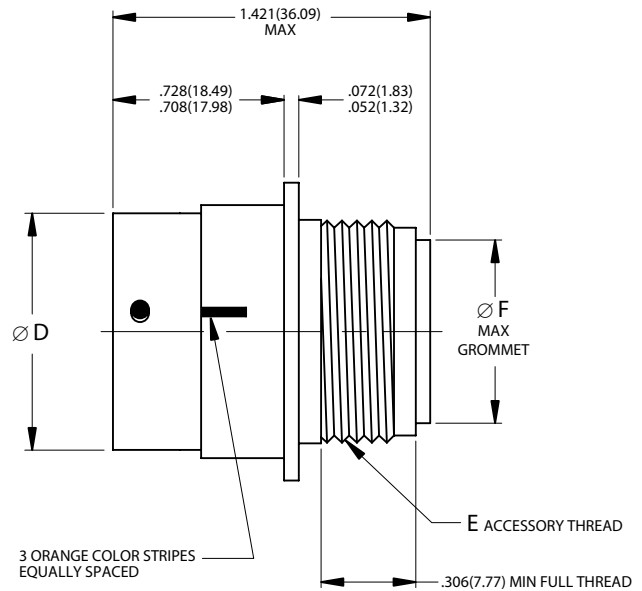
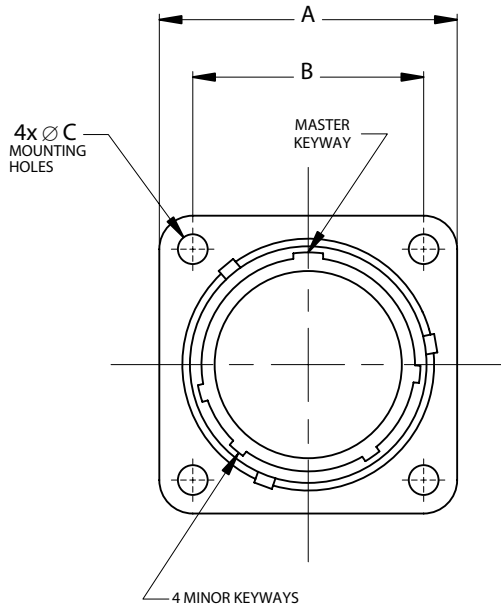

PANEL THICKNESS:
 .125(3.18)MAX

- Page 152 Completed Part Number
- Page 161 Contacts, Sealing Plugs and Tools
- Page 164 Insert Arrangements
- Page 151 Performance Specifications
- Page 163 Insert Availability and Contact Information
- Page 160 Polarization

Shell Size	A		B		Ø C		Ø D		E	Ø F	
	±.005	±.13	(TP)		+0.00	+0.00	+0.00	+0.00	Accessory Thread Class 2A	Maximum	
	inch	mm	inch	mm	inch	mm	inch	mm		inch	mm
8	.812	20.62	.594	15.09	.125	3.18	.536	13.61	7/16-28UNEF	.328	8.33
10	.937	23.80	.719	18.26	.125	3.18	.659	16.74	9/16-24UNEF	.420	10.67
12	1.031	26.19	.812	20.62	.125	3.18	.829	21.06	3/4-20UNEF	.580	14.73
14	1.125	28.58	.906	23.01	.125	3.18	.898	22.81	13/16-20UNEF	.664	16.87
16	1.250	31.75	.969	24.61	.125	3.18	1.025	26.04	15/16-20UNEF	.769	19.53
18	1.343	34.11	1.062	26.97	.125	3.18	1.131	28.73	1-1/16-18UNEF	.902	22.91
20	1.437	36.50	1.156	29.36	.125	3.18	1.256	31.90	1-3/16-18UNEF	1.033	26.24
22	1.562	39.67	1.250	31.75	.125	3.18	1.381	35.08	1-5/16-18UNEF	1.152	29.26
24	1.703	43.26	1.375	34.93	.154	3.91	1.506	38.25	1-7/16-18UNEF	1.282	32.56

26500



MS24265RB**
Jam Nut Receptacle
AE665RB**

Bayonet Coupling, Crimp Removable, Front Release

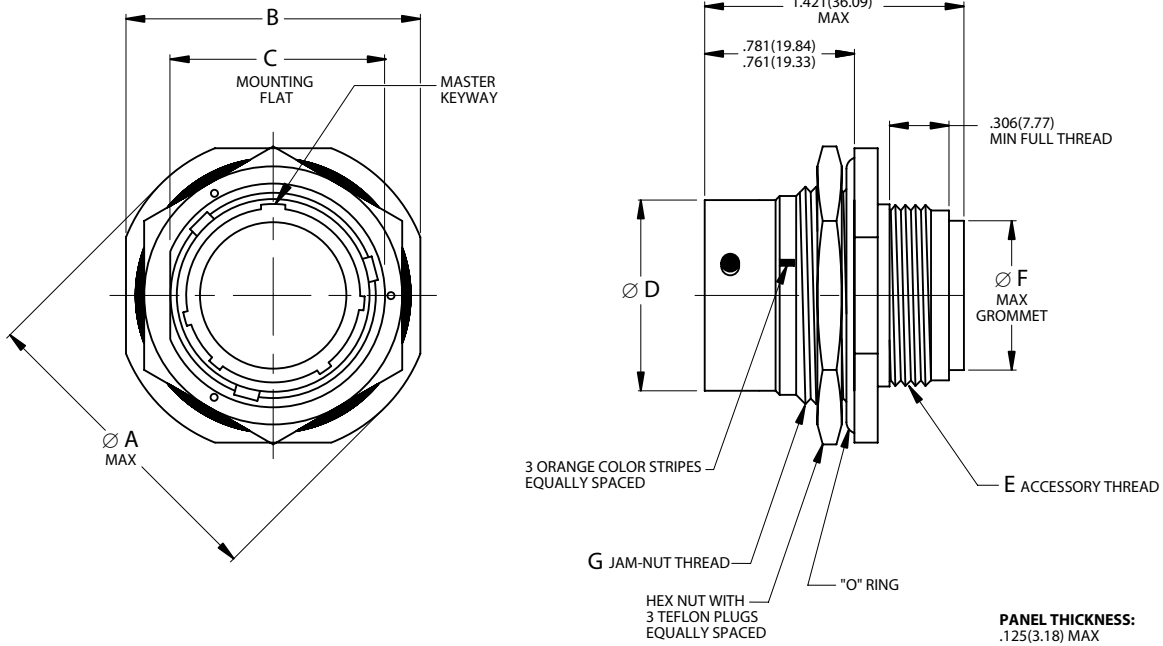

Page 152	Completed Part Number
Page 161	Contacts, Sealing Plugs and Tools
Page 164	Insert Arrangements
Page 151	Performance Specifications
Page 163	Insert Availability and Contact Information
Page 160	Polarization

Shell Size	Ø A		B		C		Ø D		E	Ø F		G
	Maximum		±.005	±.13	±.003	±.08	+0.000	+0.00	Accessory Thread Class 2A	Maximum		Jam Nut Thread Class 2A
	inch	mm	inch	mm	inch	mm	inch	mm		inch	mm	
8	1.068	27.13	.979	24.87	.593	15.06	.536	13.61	7/16-28UNEF	.328	8.33	5/8-20UN
10	1.192	30.28	1.104	28.04	.718	18.24	.659	16.74	9/16-24UNEF	.420	10.67	3/4-20UNEF
12	1.380	35.05	1.291	32.79	.905	22.99	.829	21.06	3/4-20UNEF	.580	14.73	15/16-20UNEF
14	1.505	38.23	1.391	35.33	.968	24.59	.898	22.81	13/16-20UNEF	.664	16.87	1-20UNEF
16	1.630	41.40	1.516	38.51	1.093	27.76	1.025	26.04	15/16-20UNEF	.769	19.53	1-1/8-20UN
18	1.740	44.20	1.641	41.68	1.217	30.91	1.131	28.73	1-1/16-18UNEF	.902	22.91	1-1/4-20UN
20	1.860	47.24	1.766	44.86	1.342	34.09	1.256	31.90	1-3/16-18UNEF	1.033	26.24	1-3/8-18UNEF
22	2.040	51.82	1.954	49.63	1.467	37.26	1.381	35.08	1-5/16-18UNEF	1.152	29.26	1-1/2-20UN
24	2.160	54.86	2.079	52.81	1.592	40.44	1.506	38.25	1-7/16-18UNEF	1.282	32.56	1-5/8-18UNEF

26500

MS24266RB**
Straight Plug
AE666RB**



Bayonet Coupling, Crimp Removable, Front Release

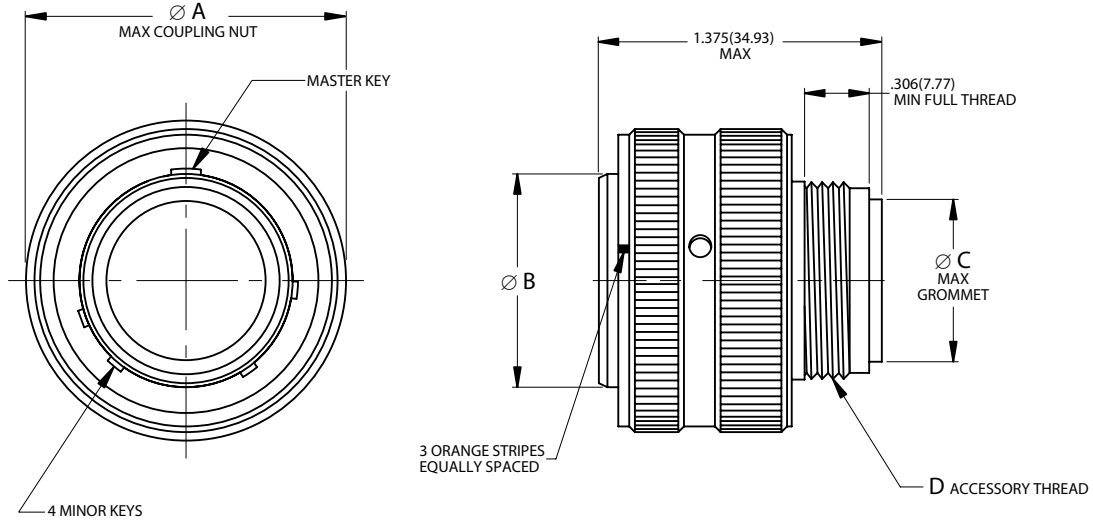

Page 152	Completed Part Number
Page 161	Contacts, Sealing Plugs and Tools
Page 164	Insert Arrangements
Page 151	Performance Specifications
Page 163	Insert Availability and Contact Information
Page 160	Polarization

Shell Size	$\varnothing A$		$\varnothing B$		$\varnothing C$		D
	Maximum		+0.00	+0.00	Maximum		Accessory Thread Class 2A
	inch	mm	-0.005	-0.13	inch	mm	
8	.776	19.71	.424	10.77	.328	8.33	7/16-28UNEF
10	.906	23.01	.526	13.36	.420	10.67	9/16-24UNEF
12	1.078	27.38	.696	17.68	.580	14.73	3/4-20UNEF
14	1.141	28.98	.765	19.43	.664	16.87	13/16-20UNEF
16	1.266	32.16	.892	22.66	.769	19.53	15/16-20UNEF
18	1.375	34.93	.998	25.35	.902	22.91	1-1/16-18UNEF
20	1.510	38.35	1.123	28.52	1.033	26.24	1-3/16-18UNEF
22	1.625	41.28	1.248	31.70	1.152	29.26	1-5/16-18UNEF
24	1.760	44.70	1.373	34.87	1.282	32.56	1-7/16-18UNEF

26500



MS24264RT**

Wall Mounting Receptacle

AE664RT**

Threaded Coupling, Crimp Removable, Front Release

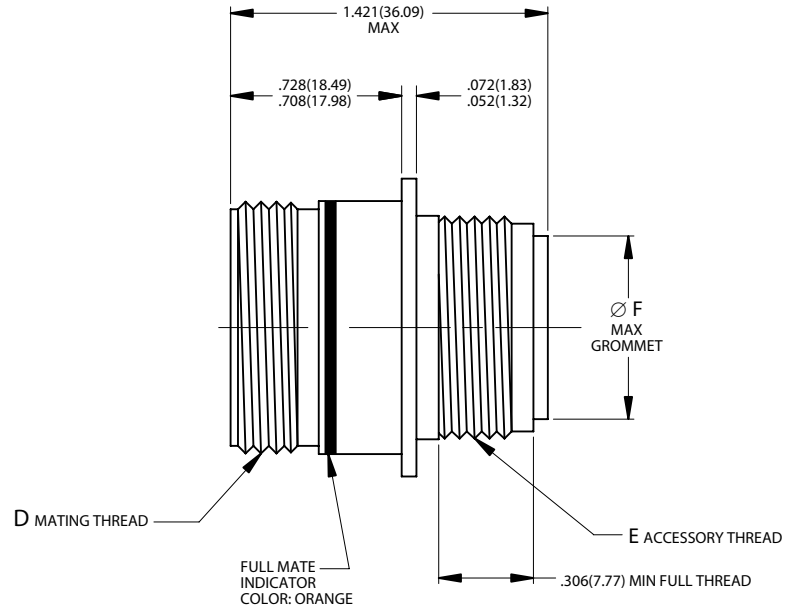
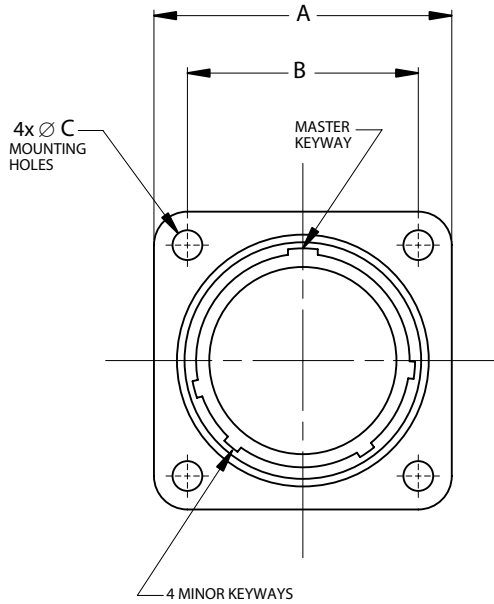

PANEL THICKNESS:
 .125(3.18) MAX

- Page 152 Completed Part Number
- Page 161 Contacts, Sealing Plugs and Tools
- Page 164 Insert Arrangements
- Page 151 Performance Specifications
- Page 163 Insert Availability and Contact Information
- Page 160 Polarization

Shell Size	A		B		\varnothing C		D	E	\varnothing F	
	\pm .005	\pm .13	(TP)		+ .000	+ .00	Mating Thread	Accessory Thread	Maximum	
	inch	mm	inch	mm	inch	mm	Class 2A	Class 2A	inch	mm
8	.812	20.62	.594	15.09	.125	3.18	9/16-24UNEF	7/16-28UNEF	.328	8.33
10	.937	23.80	.719	18.26	.125	3.18	11/16-24UNEF	9/16-24UNEF	.420	10.67
12	1.031	26.19	.812	20.62	.125	3.18	7/8-20UNEF	3/4-20UNEF	.580	14.73
14	1.125	28.58	.906	23.01	.125	3.18	15/16-20UNEF	13/16-20UNEF	.664	16.87
16	1.250	31.75	.969	24.61	.125	3.18	1-1/16-18UNEF	15/16-20UNEF	.769	19.53
18	1.343	34.11	1.062	26.97	.125	3.18	1-3/16-18UNEF	1-1/16-18UNEF	.902	22.91
20	1.437	36.50	1.156	29.36	.125	3.18	1-5/16-18UNEF	1-3/16-18UNEF	1.033	26.24
22	1.562	39.67	1.250	31.75	.125	3.18	1-7/16-18UNEF	1-5/16-18UNEF	1.152	29.26
24	1.703	43.26	1.375	34.93	.154	3.91	1-9/16-18UNEF	1-7/16-18UNEF	1.282	32.56

MS24265RT**
Jam Nut Receptacle
AE665RT**



Threaded Coupling, Crimp Removable, Front Release

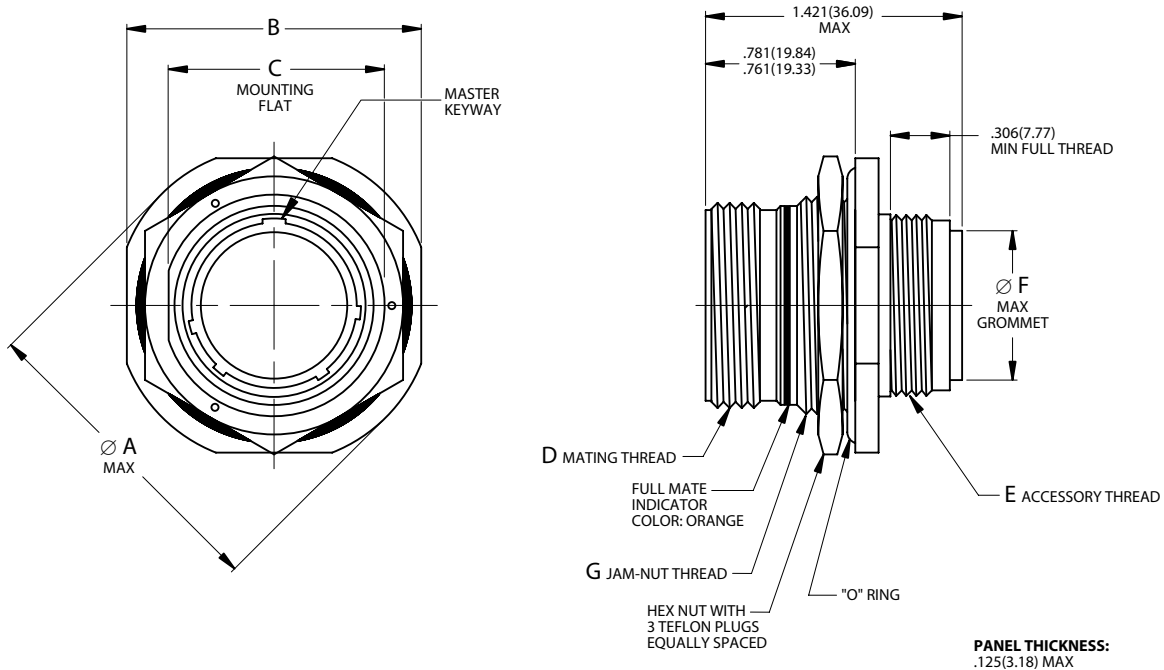

Page 152	Completed Part Number
Page 161	Contacts, Sealing Plugs and Tools
Page 164	Insert Arrangements
Page 151	Performance Specifications
Page 163	Insert Availability and Contact Information
Page 160	Polarization

Shell Size	Ø A		B		C		D	E	Ø F		G
	Maximum		±.005	±.13	±.003	±.08	Mating Thread Class 2A	Accessory Thread Class 2A	Maximum		Jam Nut Thread Class 2A
	inch	mm	inch	mm	inch	mm			inch	mm	
8	1.068	27.13	.979	24.87	.593	15.06	9/16-24UNEF	7/16-28UNEF	.328	8.33	5/8-20UN
10	1.192	30.28	1.104	28.04	.718	18.24	11/16-24UNEF	9/16-24UNEF	.420	10.67	3/4-20UNEF
12	1.380	35.05	1.291	32.79	.905	22.99	7/8-20UNEF	3/4-20UNEF	.580	14.73	15/16-20UNEF
14	1.505	38.23	1.391	35.33	.968	24.59	15/16-20UNEF	13/16-20UNEF	.664	16.87	1-20UNEF
16	1.630	41.40	1.516	38.51	1.093	27.76	1-1/16-18UNEF	15/16-20UNEF	.769	19.53	1-1/8-20UN
18	1.740	44.20	1.641	41.68	1.217	30.91	1-3/16-18UNEF	1-1/16-18UNEF	.902	22.91	1-1/4-20UN
20	1.860	47.24	1.766	44.86	1.342	34.09	1-5/16-18UNEF	1-3/16-18UNEF	1.033	26.24	1-3/8-18UNEF
22	2.040	51.82	1.954	49.63	1.467	37.26	1-7/16-18UNEF	1-5/16-18UNEF	1.152	29.26	1-1/2-20UN
24	2.160	54.86	2.079	52.81	1.592	40.44	1-9/16-18UNEF	1-7/16-18UNEF	1.282	32.56	1-5/8-18UNEF

26500



MS24266RT**
Straight Plug
AE666RT**

Threaded Coupling, Crimp Removable, Front Release

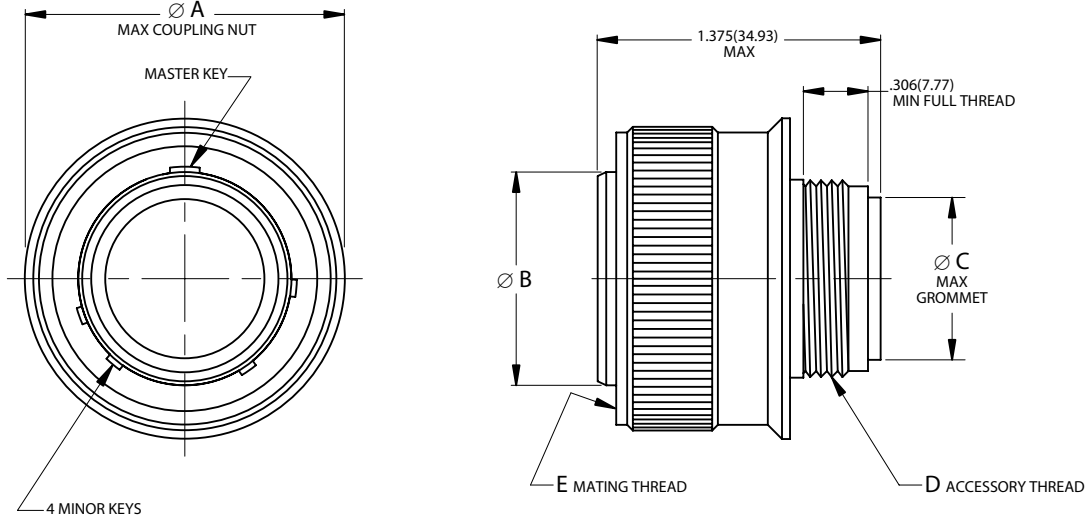

Page 152	Completed Part Number
Page 161	Contacts, Sealing Plugs and Tools
Page 164	Insert Arrangements
Page 151	Performance Specifications
Page 163	Insert Availability and Contact Information
Page 160	Polarization

Shell Size	Ø A		Ø B		Ø C		D	E
	Maximum		+0.00 -0.005	+0.00 -0.13	Maximum		Accessory Thread Class 2A	Mating Thread Class 2B
	inch	mm	inch	mm	inch	mm		
8	.776	19.71	.424	10.77	.328	8.33	7/16-28UNEF	9/16-24UNEF
10	.906	23.01	.526	13.36	.420	10.67	9/16-24UNEF	11/16-24UNEF
12	1.078	27.38	.696	17.68	.580	14.73	3/4-20UNEF	7/8-20UNEF
14	1.141	28.98	.765	19.43	.664	16.87	13/16-20UNEF	15/16-20UNEF
16	1.266	32.16	.892	22.66	.769	19.53	15/16-20UNEF	1-1/16-18UNEF
18	1.375	34.93	.998	25.35	.902	22.91	1-1/16-18UNEF	1-3/16-18UNEF
20	1.510	38.35	1.123	28.52	1.033	26.24	1-3/16-18UNEF	1-5/16-18UNEF
22	1.625	41.28	1.248	31.70	1.152	29.26	1-5/16-18UNEF	1-7/16-18UNEF
24	1.760	44.70	1.373	34.87	1.282	32.56	1-7/16-18UNEF	1-9/16-18UNEF

26500

Shell Keying

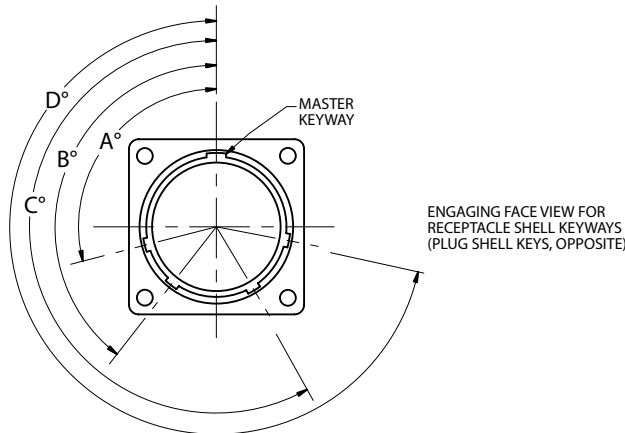

Insert Clocking

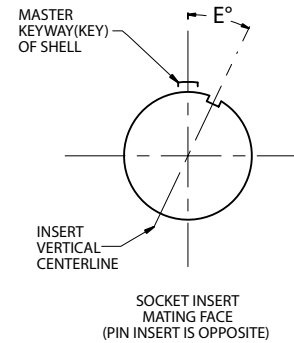

Notes:

1. In the normal position (N), the insert centerline coincides with the centerline of the master keyway (key) of the shell: $E = 0^\circ$.
2. In the alternate keying positions (6, 7, 8, 9 and Y), the minor keyways (keys) are positioned with reference to master key/keyway as indicated in the keying position table below.
3. In the alternate insert clocking positions (1, 2, 3, 4 and 5), the socket insert (viewing from the mating side) is rotated counter-clockwise relative to the centerline of the master keyway (key) of the shell. The pin insert is rotated clockwise.

Shell Size	Polarizing	Key/Keyway Positions				Insert Position
	Position	A°	B°	C°	D°	E°
8*, 10	N	105	140	215	265	0
	6	102	132	248	320	0
	7	80	118	230	312	0
	8	35	140	205	275	0
	9	64	155	234	304	0
10 only	Y**	25	115	220	270	0
12 thru 24	N	105	140	215	265	0
	6	18	149	192	259	0
	7	92	152	222	342	0
	8	84	152	204	334	0
	9	24	135	199	240	0
	Y**	98	152	268	338	0
10 thru 24	1†	105	140	215	265	10
	2†	105	140	215	265	20
	3†	105	140	215	265	30
	4†	105	140	215	265	40
	5†	105	140	215	265	50

* Per MIL-STD-1554, keyed position Y and clocked positions 1, 2, 3, 4 and 5 are not available in shell size 8.

† Per MIL-STD-1554, insert positions 1 thru 5 are inactive for new design.

** Alternate positions "Z" and "10" are cancelled and superseded by Position "Y".



MIL-DTL-26500 Bayonet and Threaded Flange and Jam Nut Receptacles Panel Cutouts

Panel Cutouts

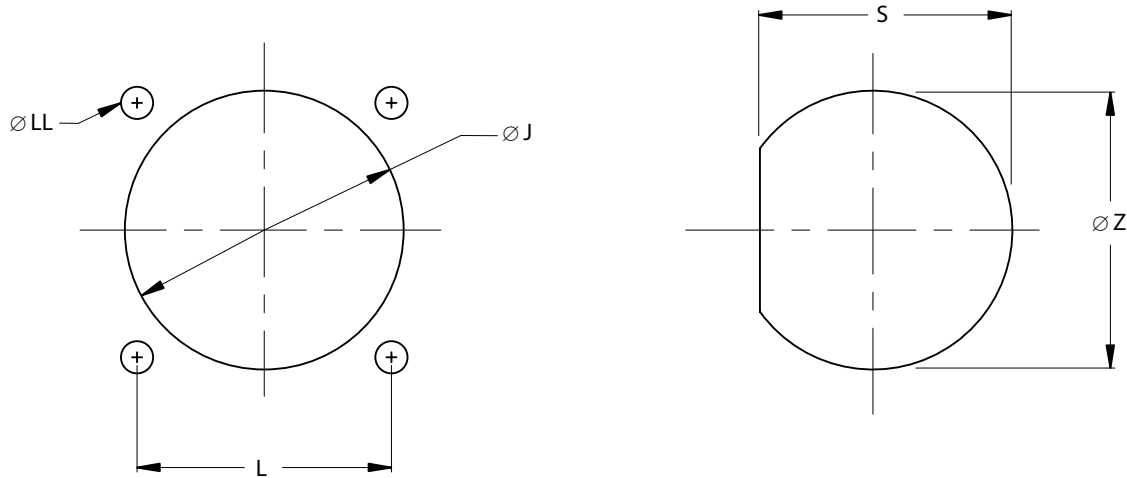

Note: Maximum panel thickness of .125 inch (3.18 mm).

Flange and Jam Nut Mounting Dimensions

Shell Size	L		$\varnothing J$		$\varnothing J$		$\varnothing LL$		S		$\varnothing Z$	
	(TP)		For Back Mounting Minimum		For Front Mounting Minimum		+0.000	+0.00	$\pm .005$		$\pm .13$	
	inch	mm	inch	mm	inch	mm	inch	mm	inch	mm	inch	mm
8	.594	15.09	.620	15.75	.447	11.35	.125	3.18	.605	15.37	.635	16.13
10	.719	18.26	.748	19.00	.572	14.53	.125	3.18	.730	18.54	.760	19.30
12	.812	20.62	.913	23.19	.760	19.30	.125	3.18	.917	23.29	.947	24.05
14	.906	23.01	.980	24.89	.822	20.88	.125	3.18	.980	24.89	1.010	25.65
16	.969	24.61	1.107	28.12	.948	24.08	.125	3.18	1.105	28.07	1.135	28.83
18	1.062	26.97	1.209	30.71	1.072	27.23	.125	3.18	1.225	31.12	1.260	32.00
20	1.156	29.36	1.337	33.96	1.192	30.28	.125	3.18	1.350	34.29	1.385	35.18
22	1.250	31.75	1.452	36.88	1.322	33.58	.125	3.18	1.475	37.47	1.510	38.35
24	1.375	34.93	1.577	40.06	1.442	36.63	.154	3.91	1.600	40.64	1.635	41.53

MIL-DTL-26500
Contacts, Tools and Seal Plugs
MS2426*/AE66*



Contacts, Plastic Insertion/Removal Tools and Seal Plugs

Contact Size	Application	Pin Contacts	Socket Contacts	Seal Plugs	Insertion/Removal Tools
	Type	Military No.	Military No.	Military No.	Military No.
					Plastic
20	Power/Signal	M39029/31-241	M39029/32-260	MS27488-20-1	N/A
16	Power/Signal	M39029/31-229	M39029/32-248	MS27488-16-1	N/A
12	Power/Signal	M39029/31-235	M39029/32-254	MS27488-12-1	N/A
8 Coax	Coax	M39029/54-343	M39029/55-345	MS27488-8-1	N/A

Crimping and Metal Insertion/Extraction Tools

Contact Size/Type	Crimp Tool	Positioner	Positioner	Insertion Tool	Extraction Tool
		For Pin Contacts	For Socket Contacts	Metal	Metal
	Military No.	Military No.	Military No.	Military No.	Military No.
20	M22520/1-01	M22520/1-02	M22520/1-02	M81969/17-03	M81969/19-07
	M22520/2-01	M22520/2-02	M22520/2-02		
16	M22520/1-01	M22520/1-02	M22520/1-02	M81969/17-04	M81969/19-08
12	M22520/1-01	M22520/1-02	M22520/1-02	M81969/17-05	M81969/19-09
8 Coax Inner	M22520/2-01	M22520/2-24	M22520/2-24	M81969/17-06	M81969/19-03
8 Coax Outer	M22520/5-01	M22520/5-10	M22520/5-10		

Contact and Wire Data

Contact Size	Test Current	Potential	Crimp Well Data			Wire Range		Finished Wire Ø Range			
	DC Test	Drop	Well Dia.	Minimum Well Dept		AWG	mm ²	Minimum		Maximum	
	Amps	Millivolts	inch	inch	mm			inch	mm	inch	mm
20	7.5	55	.049 ±.001	.267	6.78	24-20	.20-.52	.040	1.02	.090	2.29
16	13.0	49	.067 ±.001	.236	5.99	20-16	.52-1.31	.068	1.73	.130	3.30
12	23.0	42	.100 ±.002	.236	5.99	14-12	2.08-3.31	.106	2.69	.170	4.32

Note 1: Test Current and Maximum Voltage Drop when tested with silver-plated wire at 25°C.

Note 2: No plastic Insertion/Removal tools are supplied as part of contact packages when ordering 26500 connectors. Metal insertion and extraction tools must be ordered separately.



MIL-DTL-26500
Contact Installation Instructions
MS2426*/AE66*

Contact Installation Instructions

Crimping Contacts

1. Select the appropriate crimp tool and ensure that the proper crimp head positioner is used.
2. Cycle the tool to be sure the indentors are open.
3. Determine the correct selector setting for the wire size from the data plate on the positioner (turret head assembly) and set the selector knob on the crimp tool to match.
4. Place the contact, mating end first, into the tool.
5. Insert the stripped wire into the hollow end of the contact. Be sure the wire is inserted as far as it will go.
6. Close the tool completely to crimp. Unless the tool is closed completely, the tool will not release the contact.
7. Remove the crimped contact from the tool. Check the inspection hole to verify that the wire is fully inserted.

Insertion of Contacts

1. Before inserting the contacts, unscrew the accessories (clamps, backshells or adapters) from rear of plug or receptacle. Slide the hardware over the wire bundle in the proper order for reassembly after all the contacts are inserted.
2. To assist insertion of contacts, lubricate insulator (grommet) cavities with isopropyl alcohol. Alcohol will evaporate and will not leave a conductive film. **Caution: Never use any lubricant other than isopropyl alcohol.**
3. Place the correct insertion tool on the contact so that the wire runs along the groove in the tool. (Tool tip will butt against the shoulder.) Hold the plug or receptacle body firmly.

4. Beginning with a center cavity, insert the contact into the insulator with a slow, even pressure until the contact snaps into position. Make sure the contact and tool are held perpendicular to the face of the insert during the contact installation or the grommet could be damaged.
- 4.1 If contacts are not inserted all the way prior to removing insertion tool, do not try to reinsert the insertion tool. Instead, remove the contact and try again; otherwise reinserting the insertion tool may damage the inside of the contact cavity.
5. Remove tool and check the face of the connector for proper contact installation. Proper installation may also be checked by pulling back lightly on the wire to make sure the contact is properly seated.

Completion

After all the cavities have been filled, slide the hardware back into position on the connector and tighten.

Extraction of Contacts (Rework)

1. Slide the hardware back over the wire bundle.
2. Select the appropriate tool. Place tool over the contact on mating side and insert into the cavity.
3. Exert nominal force axially to release retention clip. Spacer sleeve will shoulder at face of insulation when tool is inserted to proper depth.
4. Push extraction plunger to force the contact out of the rear of the insert.
5. Grasp contact or wire and pull the wired contact out of the rear of the insulator.
6. Remove extraction tool axially.
7. After using the extraction tool, the spacer sleeve should be set forward in the last notch to protect the end of the plunger guide.

Size	Pin Contact	Socket Contact	Basic Crimp Tool	Positioner	Insertion Tool	Removal Tool
20	M39029/31-241	M39029/32-260	M22520/1-01	M22520/1-02 Red	M81969/17-03	M81969/19-07
			M22520/2-01	M22520/2-02		
16	M39029/31-229	M39029/32-248	M22520/1-01	M22520/1-02 Blue	M81969/17-04	M81969/19-08
12	M39029/31-235	M39029/32-254	M22520/1-01	M22520/1-02 Yellow	M81969/17-05	M81969/19-09

MIL-DTL-26500 Bayonet and Threaded Insert Availability and Contact Information per MIL-STD-1554



Insert Availability and Contact Information

Insert Arrangement	Aero-Electric		Total	Quantity of Contacts				Service	Alternate Positions				
	Status		No. of	(by Size)					(Insert Rotation in Degrees)				
	QPL'd	Tooled	Contacts	20	16	12	# 8 Coax	Rating	1*	2*	3*	4*	5*
8-3	Yes	Yes	3	3				I	N/A	N/A	N/A	N/A	N/A
10-5	Yes	Yes	5	5				I	10	20	30	40	50
12-3	Yes	Yes	3		3			I	10	20	30	40	50
12-12	Yes	Yes	12	12				I	10	20	30	40	50
14-7	Yes	Yes	7		7			I	10	20	30	40	50
14-12	Yes	Yes	12	9	3			I	10	20	30	40	50
14-15	Yes	Yes	15	15				I	10	20	30	40	50
16-10	Yes	Yes	10		10			I	10	20	30	40	50
16-24	Yes	Yes	24	24				I	10	20	30	40	50
18-8	Yes	Yes	8			8		I	10	20	30	40	50
18-11	Yes	Yes	11		10		1	I	10	20	30	40	50
18-14	Yes	Yes	14		14			I	10	20	30	40	50
18-31	Yes	Yes	31	31				I	10	20	30	40	50
20-16	Yes	Yes	16		16			I	10	20	30	40	50
20-25	Yes	Yes	25	19		6		I	10	20	30	40	50
20-39	Yes	Yes	39	37	2			I	10	20	30	40	50
20-41	Yes	Yes	41	41				I	10	20	30	40	50
22-19	Yes	Yes	19		19			I	10	20	30	40	50
22-55	Yes	Yes	55	55				I	10	20	30	40	50
24-30**	N/A	Yes	30		30			I	10	20	30	40	50
24-43	Yes	Yes	43	23	20			I	10	20	30	40	50
24-57	Yes	Yes	57	55		2		I	10	20	30	40	50

* Per MIL-STD-1554, insert positions 1 thru 5 are inactive for new design.

** Non MIL-STD-1554 layout, available to Aero-Electric part number only.



Insert Arrangement Views

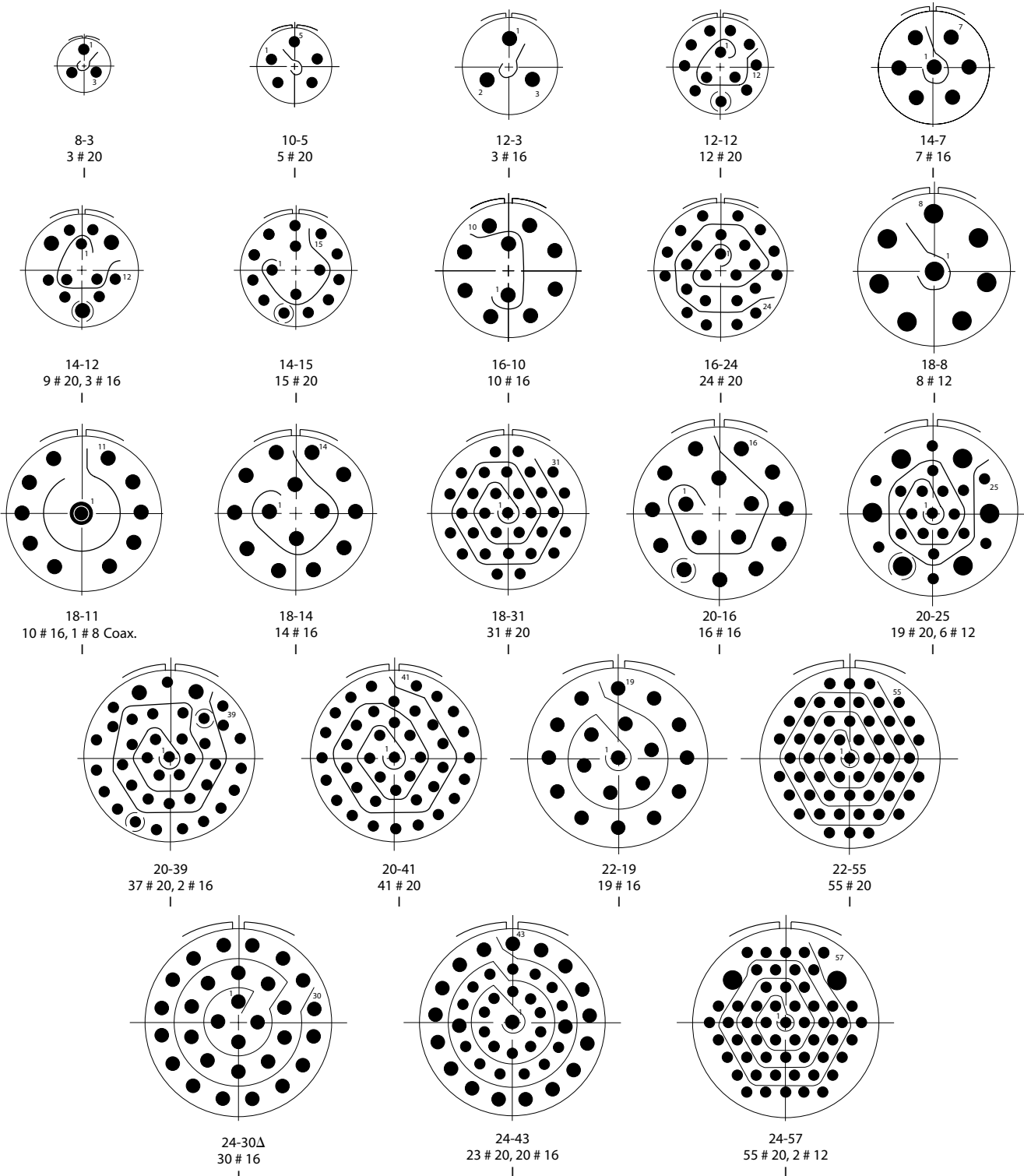

Δ Non MIL-STD-1554 layout, available to Aero-Electric part number only.