

REVISIONS					
REV	ECO	DESCRIPTION	DATE	BY	APPR
A1	--	FIRST RELEASED	Mar.26,2017	Ben	Tommy
A2	--	UPDATE NOTES	Jul-06-2017	Nick	Tommy
A3	--	UPDATE DRAWING	Mar-21-2018	White	Tommy

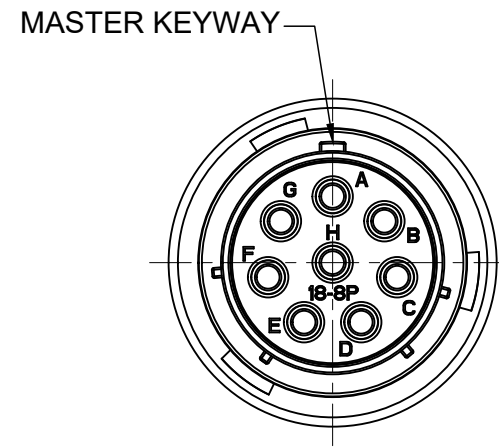

SEALING PLUGS CAN BE PURCHASED SEPARATELY

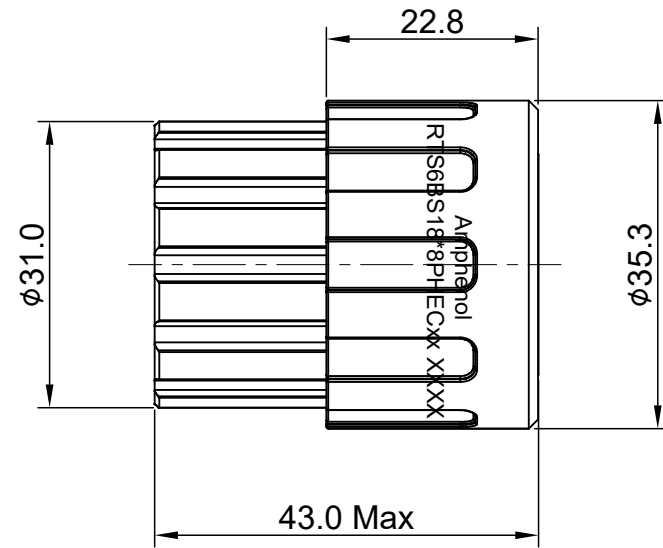
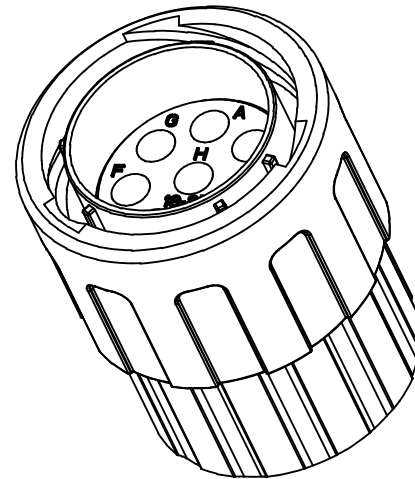
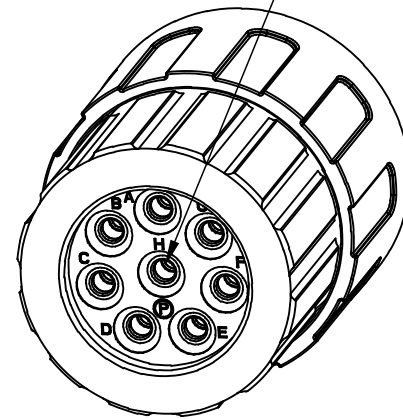

NOTES : (UNLESS OTHERWISE SPECIFIED)

- MATERIAL :
 - SHELL : THERMOPLASTIC , UL94 V-0.
 - INSERT : THERMOPLASTIC , UL94 V-0.
 - COUPLING NUT : THERMOPLASTIC , UL94 V-0.
 - O-RING : NBR OR SILICONE RUBBER.
 - WASHER: SILICONE RUBBER.
 - END CAP : THERMOPLASTIC , UL94 V-0.
 - PLASTIC RING : THERMOPLASTIC , UL94 V-0.
 - WIRE SEAL : SILICONE RUBBER.
- SPECIFICATIONS :
 - 2.1, RATED CURRENT : 23A (MAX).
 - 2.2, RATED VOLTAGE : 500V(AC/DC).
 - 2.3, OPERATING TEMPERATURE : SEE TABLE.
 - 2.4, DIELECTRIC WITHSTANDING VOLTAGE : LESS THAN 2 MILLIAMPS CURRENT LEAKAGE@2000 VOLTS AC.
 - 2.5, INSULATION RESISTANCE : 5000 MEGOHMS MIN.
 - 2.6, IP-CLASS : IP67 AND IP69K IN THE MATED CONDITION, WIRE SEALS FULLY POPULATED.
 - 2.7, MATING CYCLES DURABILITY : 500 CYCLES MIN.
 - 2.8, RoHS COMPLIANT.
- SUITABLE CONTACTS : 2.5mm CONTACT.
- ALL DIMENSIONS ARE FOR REFERENCE USE ONLY.
- CONTACT SIZE AND REAR SEAL WIRE RANGE :

CONTACT SIZE	MIN. INSUL O.D.	MAX. INSUL O.D.	WIRE RANGE
2.5MM	ø3.3MM	ø4.3MM	12 - 14AWG

KEY	PART NUMBER	
	-40°C ~ 105°C	-40°C ~ 125°C
N	RTS6BS18N8PHEC	RTS6BS18N8PHEC03

QUANTITY	PART NUMBER	DESCRIPTION	ITEM								
MATERIALS LIST											
UNLESS OTHERWISE SPECIFIED 1) All dimensions are in metric(mm). 2) Tolerances are as follows: 1 PL DEC ±0.30 2 PL DEC ±0.15 3 PL DEC ±0.08 3) Note reference =		SIGNATURES DRAWN: White CHECKED: Tod ENGINEER: APPROVAL: Tommy	DATE Mar-21-2018 Mar-21-2018 Mar-21-2018								
MATERIAL SPECIFICATIONS:		<p style="text-align: center;">Amphenol</p> <p style="text-align: center;">Sine Systems - www.amphenol-sine.com 44724 Morley Drive Clinton Township, MI 48036</p>									
PROCESS SPECIFICATIONS:		<p style="text-align: center;">ECO-MATE,PLUG,END CAP, 8POS,PIN CONTACT,SIZE 18</p>									
NEXT ASSY:		THIS DRAWING IS SUPPLIED FOR INFORMATION ONLY. DESIGN FEATURES, SPECIFICATIONS AND PERFORMANCE DATA SHOWN HEREON ARE THE PROPERTY OF THE AMPHENOL CORPORATION. NO RIGHTS OF REPRODUCTION ARE IMPLIED. ALL DIMENSIONS ARE SUBJECT TO NORMAL MANUFACTURING VARIATIONS.	<table border="1"> <tr> <td>SIZE</td> <td>TYPE</td> <td>DWG NO:</td> <td>REVISION</td> </tr> <tr> <td>B</td> <td>C-</td> <td>RTS6BS18*8PHECxx</td> <td>A3</td> </tr> </table>	SIZE	TYPE	DWG NO:	REVISION	B	C-	RTS6BS18*8PHECxx	A3
SIZE	TYPE	DWG NO:	REVISION								
B	C-	RTS6BS18*8PHECxx	A3								
SCALE: NONE		SHEET 1 OF 1									

TITLE: ECO-MATE,PLUG,END CAP,8POS,PIN CONTACT,SIZE 18
 DWG NO: RTS6BS18*8PHECXX
 REV: A3
 SH: 1
 OF: 1

ecomate® RM/RSSM/Aquarius™ - Contact Size 12 Options

Machined, Crimp Contacts				
Part Number		Contact Size (AWG)	Wire Range (mm ²)	Plating
Male	Female			
MP12B23T	MS12B23T	14-12AWG	2.3-3.5mm ²	Tin
MP12B23S	MS12B23S	14-12AWG	2.3-3.5mm ²	Silver
MP12B23F	MS12B23F	14-12AWG	2.3-3.5mm ²	Gold Flash
MP12B23G5	MS12B23G5	14-12AWG	2.3-3.5mm ²	Gold 5μ"
MP12B23G10	MS12B23G10	14-12AWG	2.3-3.5mm ²	Gold 10μ"
MP12B23G15	MS12B23G15	14-12AWG	2.3-3.5mm ²	Gold 15μ"
MP12B23G30	MS12B23G30	14-12AWG	2.3-3.5mm ²	Gold 30μ"

Machined, Tooling	
Part Number	Description
QXRT12S	Contact Extraction Tool, 2.5mm contact
UH2-5	Universal Locator, Fits AF8 and WA27F
AF8	Hand Crimper
WA27F	Pneumatic Crimper

Plating Options, All	
Symbol	Plating
T	Tin Plated
S	Silver Plated
F	Gold Flash
G5	Gold 5μ" (Thickness 5μ")
G10	Gold 10μ" (Thickness 10μ")
G15	Gold 15μ" (Thickness 15μ")
G30	Gold 30μ" (Thickness 30μ")

Stamped & Formed, Crimp Contacts				
Part Number		Contact Size (AWG)	Wire Range (mm ²)	Plating
Male	Female			
SP12A1T	SS12A1T	14-12AWG	2.5-3.5mm ²	Tin

Stamped & Formed, Tooling	
Part Number	Description
QXRT12S	Contact Extraction Tool, 2.5mm Contact
MFX-3962	Hand Tool, Stamped & Formed Contact, 2.5mm Contact

Misc Tooling, All	
Part Number	Description
CA-4012-59	Sealing Plug, Size 12

Standard Quantity Order Options	
Machined	Bag, 500 Pieces
Stamped & Formed	Reel, 1000 Pieces