

REVISIONS					
REV	ECO	DESCRIPTION	DATE	BY	APPR
A1	--	RELEASED DRAWING	Jun-30-2017	Nick	Tommy
A2	--	UPDATE DRAWING	Mar-20-2018	White	Tommy
A3	--	UPDATE DRAWING	Apr-10-2018	White	Tommy

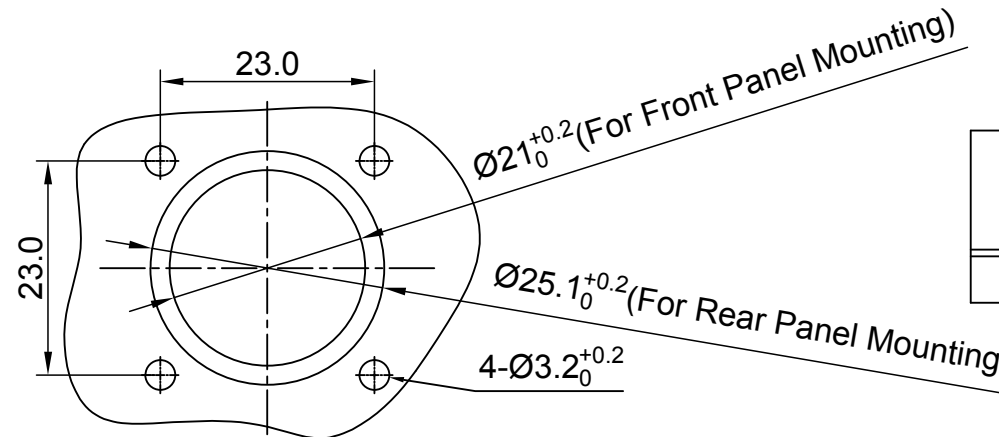
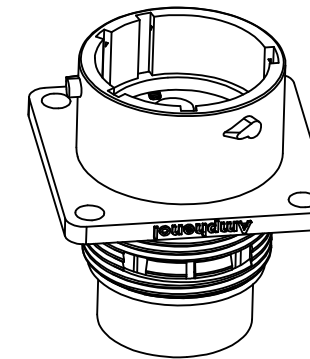
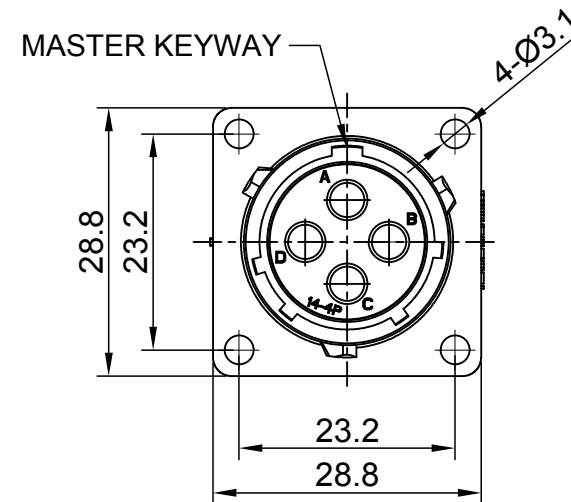
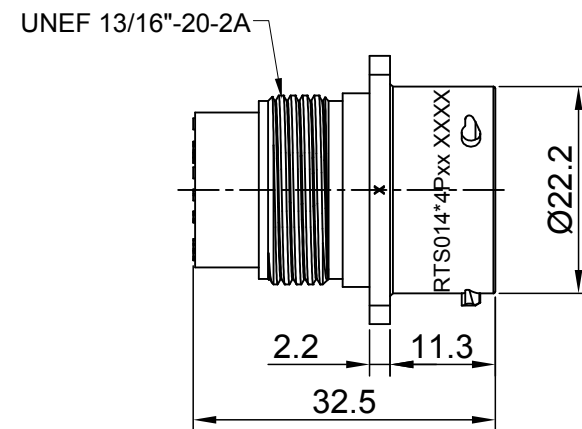

PANEL CUT OUT REFERENCE

KEY	PART NUMBER	
		-40°C ~ 105°C
N	RTS014N4P	RTS014N4P03

NOTES : (UNLESS OTHERWISE SPECIFIED)

- MATERIAL :
SHELL : THERMOPLASTIC , UL94 V-0.
INSERT : THERMOPLASTIC , UL94 V-0.
SEAL GASKET : NBR/SILICONE RUBBER.
- SPECIFICATIONS :
2.1 RATED CURRENT : 23A (MAX).
2.2 RATED VOLTAGE : 500V(AC/DC).
2.3 OPERATING TEMPERATURE : SEE CHART .
2.4 DIELECTRIC WITHSTANDING VOLTAGE : LESS THAN
2 MILLIAMPS CURRENT LEAKAGE@2000 VOLTS AC.
2.5 INSULATION RESISTANCE : 5000 MEGOHMS MIN.
2.6 IP CLASS : IP67 AND IP69K IN THE MATED CONDITION,
PANEL EXTERNAL.
2.7 MATING CYCLES DURABILITY : 500 CYCLES MIN.
2.8 RoHS COMPLIANT.
- SUITABLE CONTACTS : 2.5MM CONTACT.
- ALL DIMENSIONS ARE FOR REFERENCE USE ONLY.

QUANTITY	PART NUMBER	DESCRIPTION	ITEM
MATERIALS LIST			
UNLESS OTHERWISE SPECIFIED 1) All dimensions are in metric(mm). 2) Tolerances are as follows: 1 PL DEC ±0.30 Fractions ±1/64 2 PL DEC ±0.15 Angles ±1° 3 PL DEC ±0.08		SIGNATURES DATE DRAWN: White Apr-10-2018 CHECKED: Tod Apr-10-2018 ENGINEER: APPROVAL: Tommy Apr-10-2018	
MATERIAL SPECIFICATIONS:		CUSTOMER:	
PROCESS SPECIFICATIONS:		THIS DRAWING IS SUPPLIED FOR INFORMATION ONLY. DESIGN FEATURES, SPECIFICATIONS AND PERFORMANCE DATA SHOWN HEREON ARE THE PROPERTY OF THE AMPHENOL CORPORATION. NO RIGHTS OF REPRODUCTION ARE IMPLIED. ALL DIMENSIONS ARE SUBJECT TO NORMAL MANUFACTURING VARIATIONS.	
NEXT ASSY:		SCALE: NONE	
		<div style="text-align: center;"> <p>Sine Systems - www.amphenol-sine.com 44724 Morley Drive Clinton Township, MI 48036</p> <p>ECO-MATE, RECEPTACLE, FLANGE, SIZE 14, 4 POS, PIN</p> </div>	
		SIZE: B C- DWG NO: RTS014*4Pxx REVISION: A3	SHEET 1 OF 1

TITLE: ECO-MATE RECEPTACLE SIZE 14,4POS,PIN

DWG NO:

RTS014*4Pxx

REV: A3

SH: 1

OF: 1

ecomate® RM/RSSM/Aquarius™ - Contact Size 12 Options

Machined, Crimp Contacts				
Part Number		Contact Size (AWG)	Wire Range (mm ²)	Plating
Male	Female			
MP12B23T	MS12B23T	14-12AWG	2.3-3.5mm ²	Tin
MP12B23S	MS12B23S	14-12AWG	2.3-3.5mm ²	Silver
MP12B23F	MS12B23F	14-12AWG	2.3-3.5mm ²	Gold Flash
MP12B23G5	MS12B23G5	14-12AWG	2.3-3.5mm ²	Gold 5μ"
MP12B23G10	MS12B23G10	14-12AWG	2.3-3.5mm ²	Gold 10μ"
MP12B23G15	MS12B23G15	14-12AWG	2.3-3.5mm ²	Gold 15μ"
MP12B23G30	MS12B23G30	14-12AWG	2.3-3.5mm ²	Gold 30μ"

Machined, Tooling	
Part Number	Description
QXRT12S	Contact Extraction Tool, 2.5mm contact
UH2-5	Universal Locator, Fits AF8 and WA27F
AF8	Hand Crimper
WA27F	Pneumatic Crimper

Plating Options, All	
Symbol	Plating
T	Tin Plated
S	Silver Plated
F	Gold Flash
G5	Gold 5μ" (Thickness 5μ")
G10	Gold 10μ" (Thickness 10μ")
G15	Gold 15μ" (Thickness 15μ")
G30	Gold 30μ" (Thickness 30μ")

Stamped & Formed, Crimp Contacts				
Part Number		Contact Size (AWG)	Wire Range (mm ²)	Plating
Male	Female			
SP12A1T	SS12A1T	14-12AWG	2.5-3.5mm ²	Tin

Stamped & Formed, Tooling	
Part Number	Description
QXRT12S	Contact Extraction Tool, 2.5mm Contact
MFX-3962	Hand Tool, Stamped & Formed Contact, 2.5mm Contact

Misc Tooling, All	
Part Number	Description
CA-4012-59	Sealing Plug, Size 12

Standard Quantity Order Options	
Machined	Bag, 500 Pieces
Stamped & Formed	Reel, 1000 Pieces