

REVISIONS					
REV	ECO	DESCRIPTION	DATE	BY	APPR
B1	-	RELEASED DRAWING	JULY-17-2014	BEN	TOMMY
B2	-	UPDATING DRAWING	OCT-13-17	Flan	Tommy

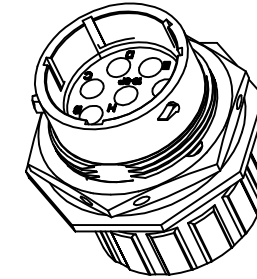
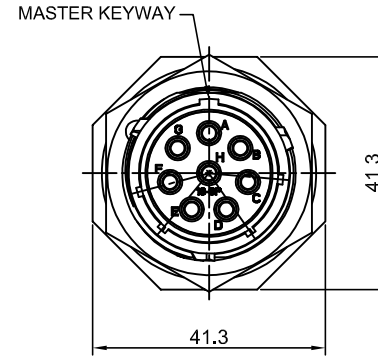
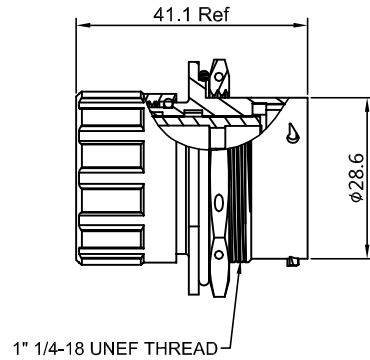

NOTES : (UNLESS OTHERWISE SPECIFIED)

1. MATERIAL :

- SHELL : ZINC ALLOY , NICKEL PLATED.
- INSERT : THERMOPLASTIC , UL94 V-0.
- END CAP : THERMOPLASTIC , UL94 V-0.
- PLASTIC BUSHING : THERMOPLASTIC , UL94 V-0.
- NUTS : AL ALLOY NICKEL PLATED.
- SEAL GASKET : NBR/SILICONE RUBBER.
- O-RING : NBR/SILICONE RUBBER.
- WIRE SEAL : SILICONE RUBBER.

2. SPECIFICATIONS :

- 2.1 RATED CURRENT : 23A (MAX).
- 2.2 RATED VOLTAGE : 500V(AC/DC).
- 2.3 OPERATING TEMPERATURE : SEE CHART.
- 2.4 DIELECTRIC WITHSTANDING VOLTAGE : LESS THAN 2 MILLIAMPS CURRENT LEAKAGE@2000 VOLTS AC.
- 2.5 INSULATION RESISTANCE : 5000 MEGOHMS MIN.
- 2.6 IP--CLASS : IP67.
- 2.7 MATING CYCLES DURABILITY : 500 CYCLES MIN.
- 2.8 RoHS COMPLIANT.

3. SUITABLE CONTACTS : 2.5mm CONTACTS.

4. ALL DIMENSIONS ARE FOR REFERENCE USE ONLY.

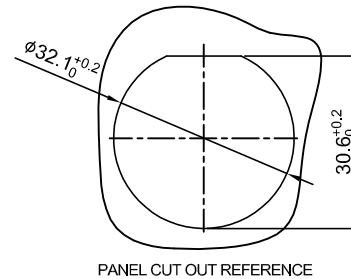

KEY POS	PART NUMBER	
	-40°C ~ 105°C	-40°C ~ 125°C
N	RT07188PNHEC	RT07188PNHEC03
W	RT07188PWHEC	RT07188PWHEC03
X	RT07188PXHEC	RT07188PXHEC03
Y	RT07188PYHEC	RT07188PYHEC03
Z	RT07188PZHEC	RT07188PZHEC03

QUANTITY	SEE PART NUMBER CHART	DESCRIPTION	ITEM
<b>MATERIALS LIST</b>			
UNLESS OTHERWISE SPECIFIED 1) All dimensions are in metric (mm). 2) Tolerances are as follows: 1 PL DEC ±0.30 2 PL DEC ±0.15 3 PL DEC ±0.08 3) Note reference =		SIGNATURES DRAWN: Flan CHECKED: Tod ENGINEER: APPROVAL: Tommy CUSTOMER:	DATE OCT-13-17 OCT-13-17 OCT-13-17
PROCESS SPECIFICATIONS:		<b>Amphenol</b> Sine Systems - www.amphenol-sine.com 44724 Morley Drive Clinton Township, MI 48036	
NEXT ASSY:		ECO-MATE, RECEPTACLE, SIZE 18,8POS,PIN,END CAP.	
THIS DRAWING IS SUPPLIED FOR INFORMATION ONLY. DESIGN FEATURES, SPECIFICATIONS AND PERFORMANCE DATA SHOWN HEREON ARE THE PROPERTY OF THE AMPHENOL CORPORATION. NO RIGHTS OF REPRODUCTION ARE IMPLIED. ALL DIMENSIONS ARE SUBJECT TO NORMAL MANUFACTURING VARIATIONS.		SIZE: B TYPE: C- SCALE: NONE	DWG NO: RT07188P*HEC* REVISION: B2
		SHEET 1 OF 1	

TITLE: ECO-MATE RECEPTACLE SIZE 18,8POS,PIN,END CAP  
DWG NO: RT07188P\*HEC\*  
REV: B2  
SH: 1  
OF: 1

# ecomate® RM/RSSM/Aquarius™ - Contact Size 12 Options

Machined, Crimp Contacts				
Part Number		Contact Size (AWG)	Wire Range (mm <sup>2</sup> )	Plating
Male	Female			
MP12B23T	MS12B23T	14-12AWG	2.3-3.5mm <sup>2</sup>	Tin
MP12B23S	MS12B23S	14-12AWG	2.3-3.5mm <sup>2</sup>	Silver
MP12B23F	MS12B23F	14-12AWG	2.3-3.5mm <sup>2</sup>	Gold Flash
MP12B23G5	MS12B23G5	14-12AWG	2.3-3.5mm <sup>2</sup>	Gold 5μ"
MP12B23G10	MS12B23G10	14-12AWG	2.3-3.5mm <sup>2</sup>	Gold 10μ"
MP12B23G15	MS12B23G15	14-12AWG	2.3-3.5mm <sup>2</sup>	Gold 15μ"
MP12B23G30	MS12B23G30	14-12AWG	2.3-3.5mm <sup>2</sup>	Gold 30μ"

Machined, Tooling	
Part Number	Description
QXRT12S	Contact Extraction Tool, 2.5mm contact
UH2-5	Universal Locator, Fits AF8 and WA27F
AF8	Hand Crimper
WA27F	Pneumatic Crimper

Plating Options, All	
Symbol	Plating
T	Tin Plated
S	Silver Plated
F	Gold Flash
G5	Gold 5μ" (Thickness 5μ")
G10	Gold 10μ" (Thickness 10μ")
G15	Gold 15μ" (Thickness 15μ")
G30	Gold 30μ" (Thickness 30μ")

Stamped & Formed, Crimp Contacts				
Part Number		Contact Size (AWG)	Wire Range (mm <sup>2</sup> )	Plating
Male	Female			
SP12A1T	SS12A1T	14-12AWG	2.5-3.5mm <sup>2</sup>	Tin

Stamped & Formed, Tooling	
Part Number	Description
QXRT12S	Contact Extraction Tool, 2.5mm Contact
MFX-3962	Hand Tool, Stamped & Formed Contact, 2.5mm Contact

Misc Tooling, All	
Part Number	Description
CA-4012-59	Sealing Plug, Size 12

Standard Quantity Order Options	
Machined	Bag, 500 Pieces
Stamped & Formed	Reel, 1000 Pieces