



# F100170 Universal Demultiplexer/Decoder

## General Description

The F100170 universal demultiplexer/decoder functions as either a dual 1-of-4 decoder or as a single 1-of-8 decoder, depending on the signal applied to the Mode Control (M) input. In the dual mode, each half has a pair of active-LOW Enable ( $\bar{E}$ ) inputs. Pin assignments for the  $\bar{E}$  inputs are such that in the 1-of-8 mode they can easily be tied together in pairs to provide two active-LOW enables ( $\bar{E}_{1a}$  to  $\bar{E}_{1b}$ ,  $\bar{E}_{2a}$  to  $\bar{E}_{2b}$ ). Signals applied to auxiliary inputs  $H_a$ ,  $H_b$  and  $H_c$  determine whether the outputs are active HIGH or active LOW. In the dual 1-of-4 mode the Address inputs are  $A_{0a}$ ,  $A_{1a}$  and

$A_{0b}$ ,  $A_{1b}$  with  $A_{2a}$  unused (i.e., left open, tied to  $V_{EE}$  or with LOW signal applied). In the 1-of-8 mode, the Address inputs are  $A_{0a}$ ,  $A_{1a}$ ,  $A_{2a}$  with  $A_{0b}$  and  $A_{1b}$  LOW or open. All inputs have 50 k $\Omega$  pulldown resistors.

Refer to the F100370 datasheet for:

- PCC packaging
- Lower power
- Military versions
- Extended voltage specs (-4.2V to -5.7V)

**Ordering Code:** See Section 8

## Logic Symbols

Single 1-of-8 Application

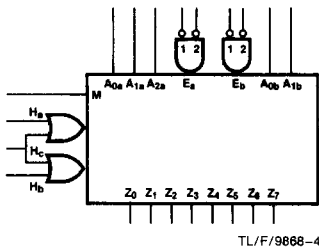

Dual 1-of-4 Application

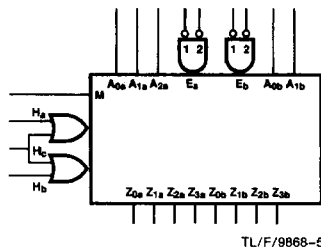

Pin Names	Description
$A_{na}, A_{nb}$	Address Inputs
$\bar{E}_{na}, \bar{E}_{nb}$	Enable Inputs
M	Mode Control Input
$H_a$	$Z_0-Z_3$ ( $\bar{Z}_{0a}-\bar{Z}_{3a}$ ) Polarity Select Input
$H_b$	$Z_4-Z_7$ ( $\bar{Z}_{0b}-\bar{Z}_{3b}$ ) Polarity Select Input
$H_c$	Common Polarity Select Input
$Z_0-Z_7$	Single 1-of-8 Data Outputs
$Z_{na}, Z_{nb}$	Dual 1-of-4 Data Outputs

## Connection Diagrams

24-Pin DIP

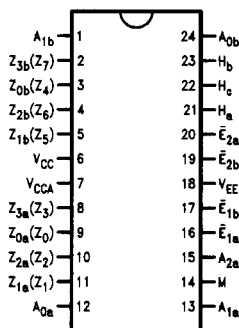

24-Pin Quad Cerpak

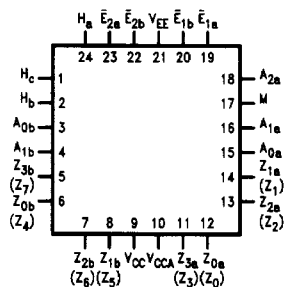

# Logic Diagram

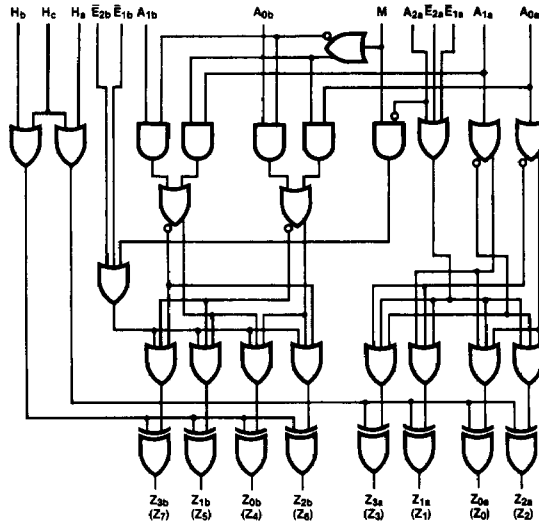

TL/F/9868-6

Note: (Z<sub>n</sub>) for 1-of-4 applications.

## Truth Tables

Dual 1-of-4 Mode (M = A<sub>2a</sub> = H<sub>c</sub> = LOW)

Inputs			Active HIGH Outputs (H <sub>a</sub> and H <sub>b</sub> Inputs HIGH)				Active LOW Outputs (H <sub>a</sub> and H <sub>b</sub> Inputs LOW)				
$\bar{E}_{1a}$ $\bar{E}_{1b}$	$\bar{E}_{2a}$ $\bar{E}_{2b}$	A <sub>1a</sub> A <sub>1b</sub>	A <sub>0a</sub> A <sub>0b</sub>	Z <sub>0a</sub> Z <sub>0b</sub>	Z <sub>1a</sub> Z <sub>1b</sub>	Z <sub>2a</sub> Z <sub>2b</sub>	Z <sub>3a</sub> Z <sub>3b</sub>	Z <sub>0a</sub> Z <sub>0b</sub>	Z <sub>1a</sub> Z <sub>1b</sub>	Z <sub>2a</sub> Z <sub>2b</sub>	Z <sub>3a</sub> Z <sub>3b</sub>
H	X	X	X	L	L	L	L	H	H	H	H
X	H	X	X	L	L	L	L	H	H	H	H
L	L	L	L	H	L	L	L	L	H	H	H
L	L	L	H	L	H	L	L	L	L	H	H
L	L	H	L	L	L	H	L	H	L	L	H
L	L	H	H	L	L	L	H	H	H	H	L

Single 1-of-8 Mode (M = HIGH; A<sub>0b</sub> = A<sub>1b</sub> = H<sub>a</sub> = H<sub>b</sub> = LOW)

Inputs					Active HIGH Outputs* (H <sub>c</sub> Input HIGH)							
$\bar{E}_1$	$\bar{E}_2$	A <sub>2a</sub>	A <sub>1a</sub>	A <sub>0a</sub>	Z <sub>0</sub>	Z <sub>1</sub>	Z <sub>2</sub>	Z <sub>3</sub>	Z <sub>4</sub>	Z <sub>5</sub>	Z <sub>6</sub>	Z <sub>7</sub>
H	X	X	X	X	L	L	L	L	L	L	L	L
X	H	X	X	X	L	L	L	L	L	L	L	L
L	L	L	L	L	H	L	L	L	L	L	L	L
L	L	L	L	H	L	H	L	L	L	L	L	L
L	L	L	H	L	L	L	H	L	L	L	L	L
L	L	L	H	H	L	L	L	H	L	L	L	L
L	L	H	L	L	L	L	L	L	H	L	L	L
L	L	H	L	H	L	L	L	L	L	H	L	L
L	L	H	H	L	L	L	L	L	L	L	H	L
L	L	H	H	H	L	L	L	L	L	L	L	H

H = HIGH Voltage Level

L = LOW Voltage Level

X = Don't Care

\*for H<sub>c</sub> = LOW, output states are complemented

$\bar{E}_1 = \bar{E}_{1a}$  and  $\bar{E}_{1b}$  wired;  $\bar{E}_2 = \bar{E}_{2a}$  and  $\bar{E}_{2b}$  wired

### Absolute Maximum Ratings

Above which the useful life may be impaired. (Note 1)

**If Military/Aerospace specified devices are required, please contact the National Semiconductor Sales Office/Distributors for availability and specifications.**

Storage Temperature                    -65°C to +150°C  
 Maximum Junction Temperature (T<sub>J</sub>)       +150°C

Case Temperature under Bias (T<sub>C</sub>)           0°C to +85°C  
 V<sub>EE</sub> Pin Potential to Ground Pin       -7.0V to +0.5V  
 Input Voltage (DC)                       V<sub>EE</sub> to +0.5V  
 Output Current (DC Output HIGH)       -50 mA  
 Operating Range (Note 2)               -5.7V to -4.2V

### DC Electrical Characteristics

V<sub>EE</sub> = -4.5V, V<sub>CC</sub> = V<sub>CCA</sub> = GND, T<sub>C</sub> = 0°C to +85°C (Note 3)

Symbol	Parameter	Min	Typ	Max	Units	Conditions (Note 4)	
V <sub>OH</sub>	Output HIGH Voltage	-1025	-955	-880	mV	V <sub>IN</sub> = V <sub>IH</sub> (Max) or V <sub>IL</sub> (Min)	Loading with 50Ω to -2.0V
V <sub>OL</sub>	Output LOW Voltage	-1810	-1705	-1620			
V <sub>OHC</sub>	Output HIGH Voltage	-1035			mV	V <sub>IN</sub> = V <sub>IH</sub> (Min) or V <sub>IL</sub> (Max)	Loading with 50Ω to -2.0V
V <sub>OLC</sub>	Output LOW Voltage			-1610			
V <sub>IH</sub>	Input HIGH Voltage	-1165		-880	mV	Guaranteed HIGH Signal for All Inputs	
V <sub>IL</sub>	Input LOW Voltage	-1810		-1475	mV	Guaranteed LOW Signal for All Inputs	
I <sub>IL</sub>	Input LOW Current	0.50			μA	V <sub>IN</sub> = V <sub>IL</sub> (Min)	

### DC Electrical Characteristics

V<sub>EE</sub> = -4.2V, V<sub>CC</sub> = V<sub>CCA</sub> = GND, T<sub>C</sub> = 0°C to +85°C (Note 3)

Symbol	Parameter	Min	Typ	Max	Units	Conditions (Note 4)	
V <sub>OH</sub>	Output HIGH Voltage	-1020		-870	mV	V <sub>IN</sub> = V <sub>IH</sub> (Max) or V <sub>IL</sub> (Min)	Loading with 50Ω to -2.0V
V <sub>OL</sub>	Output LOW Voltage	-1810		-1605			
V <sub>OHC</sub>	Output HIGH Voltage	-1030			mV	V <sub>IN</sub> = V <sub>IH</sub> (Min) or V <sub>IL</sub> (Max)	Loading with 50Ω to -2.0V
V <sub>OLC</sub>	Output LOW Voltage			-1595			
V <sub>IH</sub>	Input HIGH Voltage	-1150		-870	mV	Guaranteed HIGH Signal for All Inputs	
V <sub>IL</sub>	Input LOW Voltage	-1810		-1475	mV	Guaranteed LOW Signal for All Inputs	
I <sub>IL</sub>	Input LOW Current	0.50			μA	V <sub>IN</sub> = V <sub>IL</sub> (Min)	

### DC Electrical Characteristics

V<sub>EE</sub> = -4.8V, V<sub>CC</sub> = V<sub>CCA</sub> = GND, T<sub>C</sub> = 0°C to +85°C (Note 3)

Symbol	Parameter	Min	Typ	Max	Units	Conditions (Note 4)	
V <sub>OH</sub>	Output HIGH Voltage	-1035		-880	mV	V <sub>IN</sub> = V <sub>IH</sub> (Max) or V <sub>IL</sub> (Min)	Loading with 50Ω to -2.0V
V <sub>OL</sub>	Output LOW Voltage	-1830		-1620			
V <sub>OHC</sub>	Output HIGH Voltage	-1045			mV	V <sub>IN</sub> = V <sub>IH</sub> (Min) or V <sub>IL</sub> (Max)	Loading with 50Ω to -2.0V
V <sub>OLC</sub>	Output LOW Voltage			-1610			
V <sub>IH</sub>	Input HIGH Voltage	-1165		-880	mV	Guaranteed HIGH Signal for All Inputs	
V <sub>IL</sub>	Input LOW Voltage	-1830		-1490	mV	Guaranteed LOW Signal for All Inputs	
I <sub>IL</sub>	Input LOW Current	0.50			μA	V <sub>IN</sub> = V <sub>IL</sub> (Min)	

**Note 1:** Absolute maximum ratings are those values beyond which the device may be damaged or have its useful life impaired. Functional operation under these conditions is not implied.

**Note 2:** Parametric values specified at -4.2V to -4.8V.

**Note 3:** The specified limits represent the "worst case" value for the parameter. Since these "worst case" values normally occur at the temperature extremes, additional noise immunity and guard banding can be achieved by decreasing the allowable system operating ranges.

**Note 4:** Conditions for testing shown in the tables are chosen to guarantee operation under "worst case" conditions.

**DC Electrical Characteristics** $V_{EE} = -4.2V$  to  $-4.8V$  unless otherwise specified,  $V_{CC} = V_{CCA} = GND$ ,  $T_C = 0^\circ C$  to  $+85^\circ C$ 

Symbol	Parameter	Min	Typ	Max	Units	Conditions
$I_{IH}$	Input HIGH Current $H_c, A_{0a}, A_{1a}, A_{2a}$ All Others			310 250	$\mu A$	$V_{IN} = V_{IH}(\text{Max})$
$I_{EE}$	Power Supply Current	-153	-109	-76	mA	Inputs Open

**Ceramic Dual-In-Line Package AC Electrical Characteristics** $V_{EE} = -4.2V$  to  $-4.8V$ ,  $V_{CC} = V_{CCA} = GND$ 

Symbol	Parameter	$T_C = 0^\circ C$		$T_C = +25^\circ C$		$T_C = +85^\circ C$		Units	Conditions
		Min	Max	Min	Max	Min	Max		
$t_{PLH}$ $t_{PHL}$	Propagation Delay $\bar{E}_{na}, \bar{E}_{nb}$ to Output	0.90	2.30	0.90	2.20	0.90	2.30	ns	<i>Figures 1 and 2</i>
$t_{PLH}$ $t_{PHL}$	Propagation Delay $A_{na}, A_{nb}$ to Output	1.00	2.80	1.00	2.70	1.00	2.90	ns	
$t_{PLH}$ $t_{PHL}$	Propagation Delay $H_a, H_b, H_c$ to Output	1.00	3.00	1.00	2.90	1.00	3.00	ns	
$t_{PLH}$ $t_{PHL}$	Propagation Delay M to Output	1.50	3.90	1.60	3.80	1.60	3.90	ns	
$t_{TLH}$ $t_{THL}$	Transition Time 20% to 80%, 80% to 20%	0.45	1.70	0.45	1.70	0.45	1.80	ns	

**Cerpak AC Electrical Characteristics** $V_{EE} = -4.2V$  to  $-4.8V$ ,  $V_{CC} = V_{CCA} = GND$ 

Symbol	Parameter	$T_C = 0^\circ C$		$T_C = +25^\circ C$		$T_C = +85^\circ C$		Units	Conditions
		Min	Max	Min	Max	Min	Max		
$t_{PLH}$ $t_{PHL}$	Propagation Delay $\bar{E}_{na}, \bar{E}_{nb}$ to Output	0.90	2.10	0.90	2.00	0.90	2.10	ns	<i>Figures 1 and 2</i>
$t_{PLH}$ $t_{PHL}$	Propagation Delay $A_{na}, A_{nb}$ to Output	1.00	2.60	1.00	2.50	1.00	2.70	ns	
$t_{PLH}$ $t_{PHL}$	Propagation Delay $H_a, H_b, H_c$ to Output	1.00	2.80	1.00	2.70	1.00	2.80	ns	
$t_{PLH}$ $t_{PHL}$	Propagation Delay M to Output	1.50	3.70	1.60	3.60	1.60	3.70	ns	
$t_{TLH}$ $t_{THL}$	Transition Time 20% to 80%, 80% to 20%	0.45	1.60	0.45	1.60	0.45	1.70	ns	

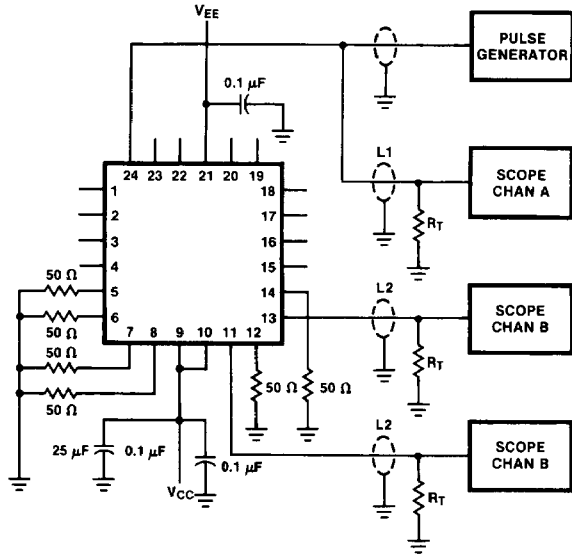

FIGURE 1. AC Test Circuit

TL/F/9868-7

**Notes:**

- $V_{CC}, V_{CCA} = +2V, V_{EE} = -2.5V$
- L1 and L2 = equal length 50Ω impedance lines
- $R_T = 50\Omega$  terminator internal to scope
- Decoupling 0.1 μF from GND to  $V_{CC}$  and  $V_{EE}$
- All unused outputs are loaded with 50Ω to GND
- $C_L =$  Fixture and stray capacitance  $\leq 3$  pF
- Pin numbers shown are for flatpak; for DIP see logic symbol

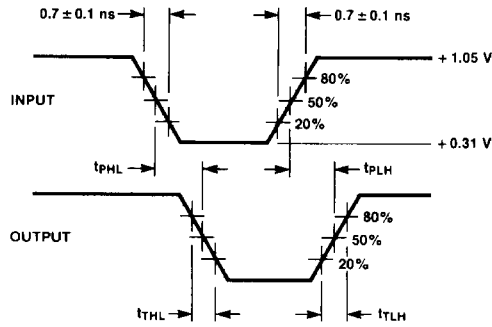

FIGURE 2. Propagation Delay and Transition Times

TL/F/9868-8