

General Description

The MX7219T of push-pull output comparators feature a fast 4.5ns propagation delay and operation from +2.7V to +5.5V. Beyond-the-rails input common-mode range makes it an ideal choice for low-voltage applications. The rail-to-rail output directly drives either CMOS or TTL logic.

Micro size packages provide options for portable and space-restricted applications. The MX7219T is available in SOT23-5.

Features

- ◆ High speed: 4.5ns
- ◆ Rail-to-rail I/O
- ◆ Supply voltage: +2.7V to +5.5V
- ◆ Push-pull CMOS output stage
- ◆ Low supply current: 3.2mA
- ◆ 6-pin SOT23-6L

Applications

- ◆ Automatic test equipment
- ◆ Wireless base stations

Terminal Assignments

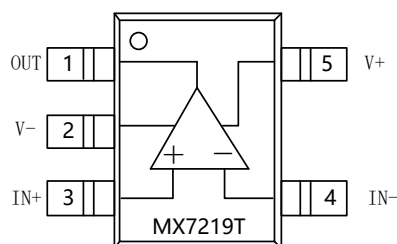

Pin information

- ◆ Threshold detector
- ◆ Zero-crossing detector

General Information

Ordering Information

Part Number	Description
MX7219T	SOT23-5L
MPQ	3000pcs

Package Dissipation Rating

Package	R θ JA (°C/W)
SOT-23 (5)	200

Absolute Maximum Ratings

Parameter	Value
Supply Voltage	+5.5V
Signal Input Terminals	(V-) - 0.3V to (V+) + 0.3V
Signal Input Terminals Current	10mA
Output Short Circuit	74mA
Junction Temperature	150°C
Storage Temperature, Tstg	-50 to 150°C
Leading Temperature (soldering, 10secs)	260°C
ESD susceptibility HBM	±2000V
Charged-Device Model (CDM)	500V

Stresses beyond those listed in Absolute Maximum Ratings may cause permanent damage to the device. Exposure to absolute maximum rating conditions for extended periods may affect reliability. Functional operation of the device at any conditions beyond those indicated in the Recommended Operating Conditions section is not implied.

Recommended Operating Condition

Symbol	Range
Supply Voltage	2.7V~5.5V
Operating temperature	-40~125°C

Electrical Characteristics

($V_S = +2.7V$ to $+5.5V$, $T_A = 25^\circ C$, unless otherwise noted)

Symbol	Parameter	Test condition	Min	Typ.	Max	Unit
Offset Voltage						
V_{OS}	Input Offset Voltage ⁽¹⁾	$V_{CM} = 0V, I_O = 0mA$		± 1	± 6.5	mV
dV_{OS}/dT	Offset Voltage vs Temperature	$T_A = -40^\circ C$ to $+125^\circ C$		± 5		$\mu V/^\circ C$
PSRR	Offset Voltage vs Power Supply	$V_S = 2.7V$ to $5.5V$		100	400	$\mu V/V$
Input Hysteresis				6		mV
Input Bias Current						
I_B	Input Bias Current	$V_{CM} = V_{CC}/2 \pm 2V$		± 2	± 10	pA
I_{OS}	Input Offset Current ⁽²⁾			± 2	± 10	pA
Input Voltage Range						
V_{CM}	Common-Mode Voltage Range	$V_{CM} = -0.2V$ to $(V+) + 0.2V$	$(V-) - 0.2V$		$(V+) + 0.2V$	V
CMRR	Common-Mode Rejection		55		70	dB
Input Impedance						
Common-Mode				$10^{13} \parallel 2$		$\Omega \parallel pF$
Differential				$10^{13} \parallel 4$		$\Omega \parallel pF$
Switching Characteristics						
T_{pd}	Propagation Delay Time ⁽³⁾	$\Delta V_{IN} = 100mV$, Overdrive = $20mV$		5	8	ns
		$\Delta V_{IN} = 100mV$, Overdrive = $5mV$	7.5		12	ns
Δt_{SKEW}	Propagation Delay Skew ⁽⁴⁾	$\Delta V_{IN} = 100mV$, Overdrive = $20mV$		0.5		ns
f_{MAX}	Maximum Toggle Frequency	Overdrive = $50mV$, $V_S = 5V$		80		MHz
t_R	Rise Time ⁽⁵⁾			1.5		ns
t_F	Fall Time ⁽⁵⁾			1.5		ns
Output						
V_{OH}, V_{OL}	Voltage Output from Rail	$I_{OUT} = \pm 1mA$	-50	30	50	mV
Power Supply						
V_S	Specified Voltage		+2.7		+5.5	V
Operating Voltage Range	Operating Voltage Range		2.2		5.5	V
I_Q	Quiescent Current	$V_S = 5V, V_O = High$	2	3.6	5	mA

(1) V_{OS} is defined as the average of the positive and the negative switching thresholds.

(2) The difference between I_{B+} and I_{B-} .

(3) Propagation delay cannot be accurately measured with low overdrive on automatic test equipment. This parameter is ensured by characterization and testing at 100mV overdrive.

(4) The difference between the propagation delay going high and the propagation delay going low.

(5) Measured between 10% of V_S and 90% of V_S .

Characteristic Plots

(At $T_A = +25^\circ\text{C}$, $V_S = +5\text{V}$, and Input Overdrive = 100mV, unless otherwise noted.)

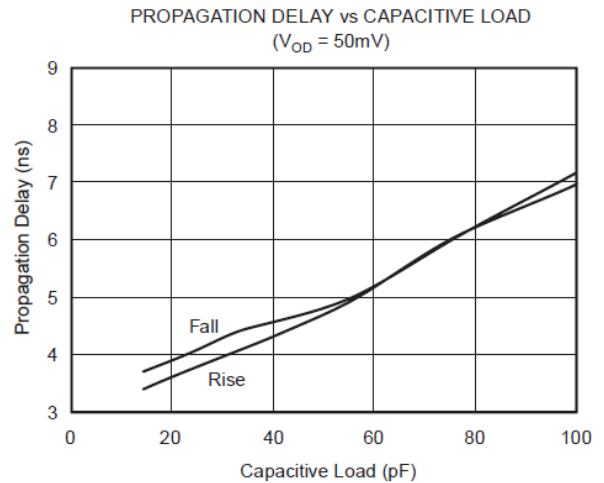
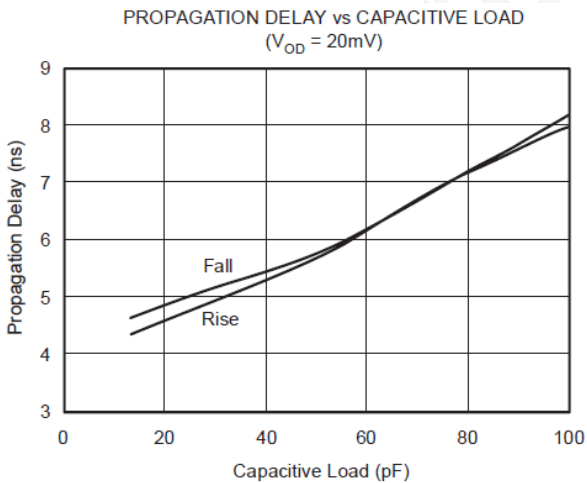
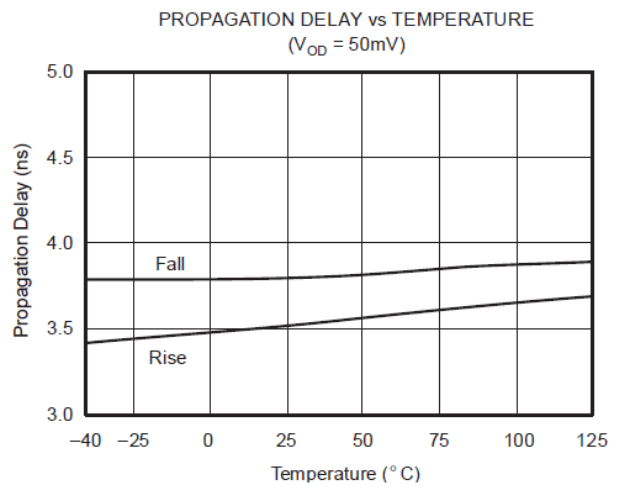
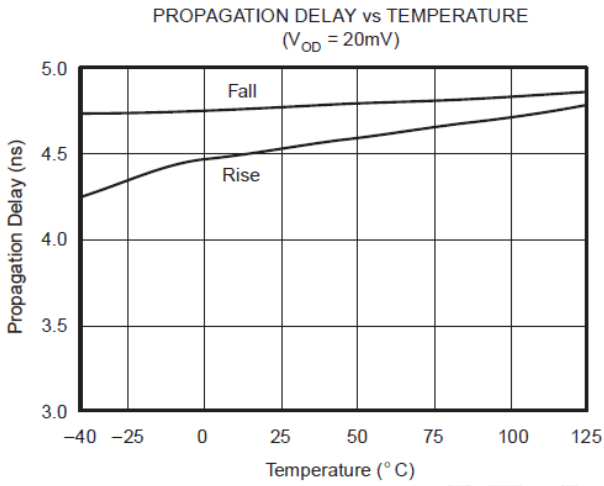
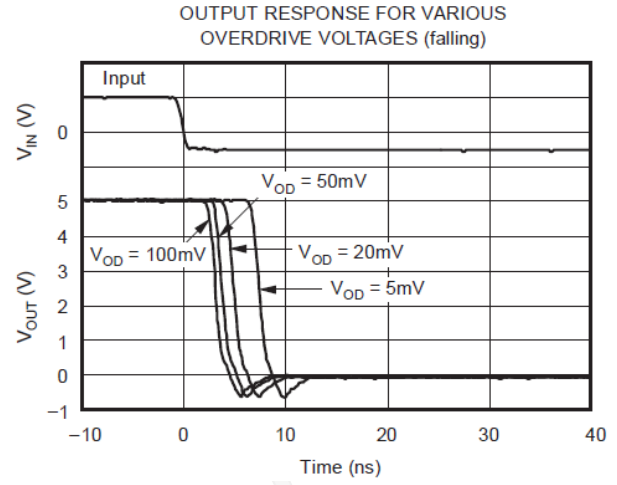
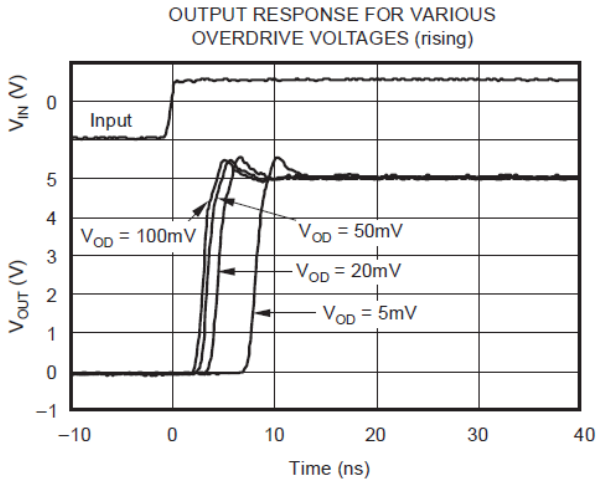

4.5ns Rail-to-Rail, High-Speed Comparator

PROPAGATION DELAY vs SUPPLY VOLTAGE
($V_{CM} = 1V, V_{OD} = 20mV$)

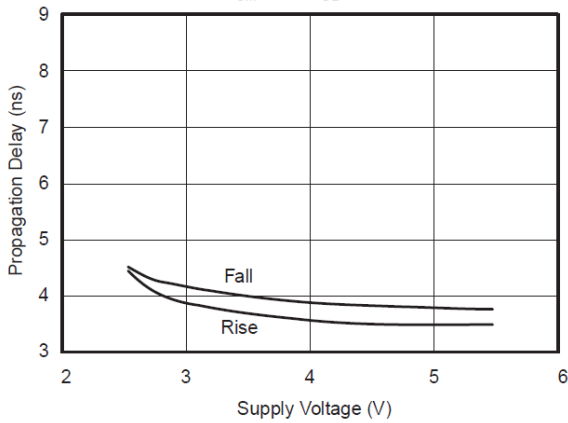

WAKE-UP DELAY vs TEMPERATURE

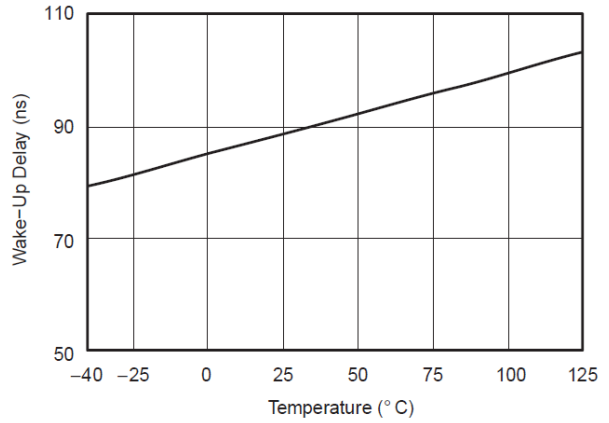

RESPONSE TO 50MHz SINE WAVE
($V_{DD} = 5V, V_{IN} = 20mV_{PP}$)

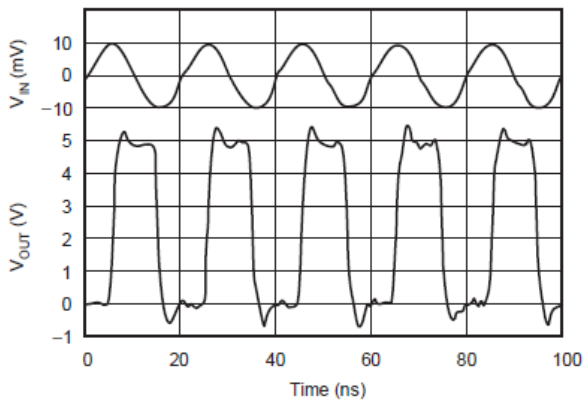

RESPONSE TO 100MHz SINE WAVE
($\pm 2.5V$ dual supply into 50Ω oscilloscope input)

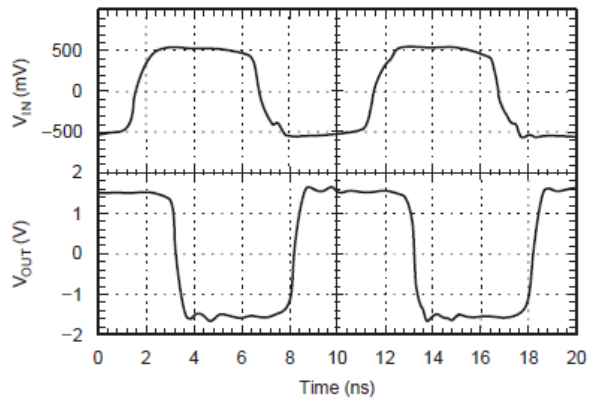

QUIESCENT CURRENT vs SUPPLY VOLTAGE

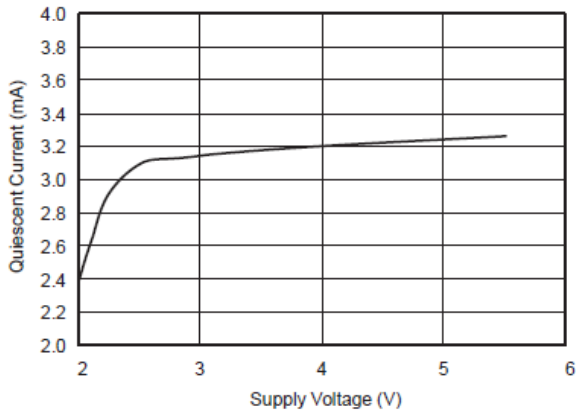

QUIESCENT CURRENT vs TEMPERATURE

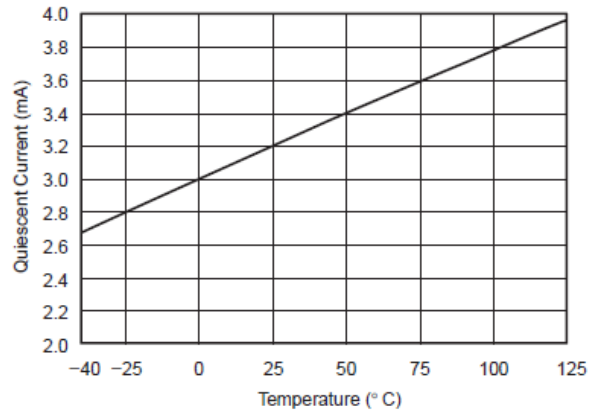

4.5ns Rail-to-Rail, High-Speed Comparator

Operation Description

The MX7219T features high-speed response and includes 6mV of internal hysteresis for improved noise immunity with an input common-mode range that extends 0.2V beyond the power-supply rails.

Operating Voltage

MX7219T comparators are specified for use on a single supply from +2.7V to +5.5V (or a dual supply from ±1.35V to ±2.75V) over a temperature range of -40°C to +125°C. The device continues to function below this range, but performance is not specified.

Adding External Hysteresis

The MX7219T has a robust performance when used with a good layout. However, comparator inputs have little noise immunity within the range of specified offset voltage (±5mV). For slow moving or noisy input signals, the comparator output may display multiple switching as input signals move through the switching threshold. In such applications, the 6mV of internal hysteresis of the MX7219T might not be sufficient. In cases where greater noise immunity is desired, external hysteresis may be added by connecting a small amount of feedback to the positive input. The following figure shows a typical topology used to introduce 25mV of additional hysteresis, for a total of 31mV hysteresis when operating from a single 5V supply. Total hysteresis is approximated by the following equation:

$$V_{HYST} = (V_S) \times R_1 / (R_1 + R_2) + 6mV$$

V_{HYST} sets the value of the transition voltage required to switch the comparator output by enlarging the threshold region, thereby reducing sensitivity to noise.

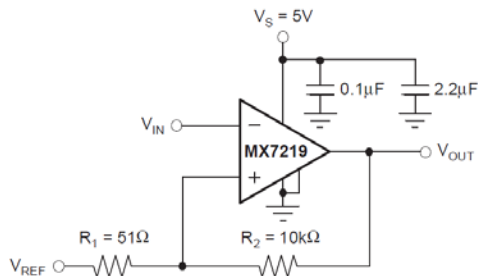

Adding Hysteresis

Input Over-Voltage Protection

Device inputs are protected by ESD diodes that will conduct if the input voltages exceed the power supplies by more than

approximately 300mV. Momentary voltages greater than 300mV beyond the power supply can be tolerated if the input current is limited to 10mA. This limiting is easily accomplished with a small input resistor in series with the comparator, as shown in the following figure.

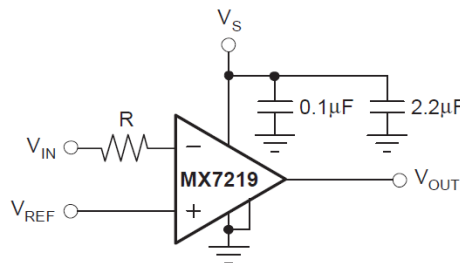

Input Current Protection for Voltages Exceeding the Supply Voltage

Relaxation Oscillator

The MX7219T can easily be configured as a simple and inexpensive relaxation oscillator. In the following figure, the R2 network sets the trip threshold at 1/3 and 2/3 of the single supply. Since this is a high-speed circuit, the resistor values are rather low to minimize the effect of parasitic capacitance. The positive input alternates between 1/3 of V_S and 2/3 of V_S depending on whether the output is low or high. The time to charge (or discharge) is $0.69R_1C$. Therefore, the period is $1.38R_1C$. For 62pF and 1KΩ as shown in the following figure, the output is calculated to be 10.9MHz. An implementation of this circuit oscillated at 9.6MHz. Parasitic capacitance and component tolerances explain the difference between theory and actual performance.

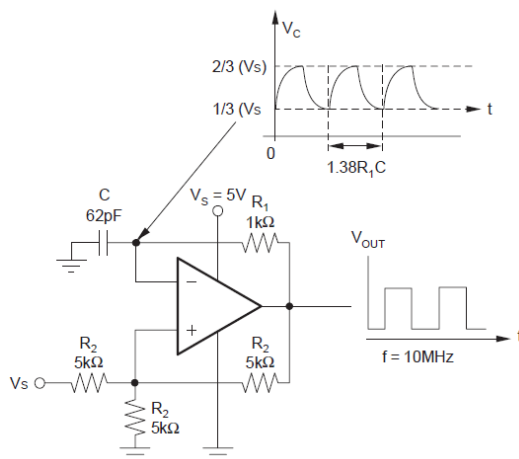

Relaxation Oscillator

PCB Layout

For any high-speed comparator or amplifier, proper design, and printed circuit board (PCB) layout are necessary for optimal performance. Excess stray capacitance on the active input, or improper grounding, can limit the maximum performance of high-speed circuitry.

Minimizing resistance from the signal source to the comparator input is necessary to minimize the propagation delay of the complete circuit. The source resistance along with input and stray capacitance creates an RC filter that delays voltage transitions at the input and reduces the amplitude of high-frequency signals. The input capacitance of the MX7219T along with stray capacitance from an input pin to ground results in several picofarads of capacitance.

The location and type of capacitors used for power-supply bypassing is critical to high-speed comparators. The suggested 2.2 μ F tantalum capacitor do not need to be as close to the device as the 0.1 μ F capacitor and may be shared with other devices. The 2.2 μ F capacitor buffers the power-supply line against ripple, and the 0.1 μ F capacitor provides a charge for the comparator during high-frequency switching.

In a high-speed circuit, fast rising and falling switching transients create voltage differences across lines that would be at the same potential at DC. To reduce this effect, a ground plane is often used to reduce difference in voltage potential within the circuit board. A ground plane has the advantage of minimizing the effect of stray capacitances on the circuit board by providing a more desirable path for the current to flow. With a signal trace over a ground plane, at high frequency the return current (in the ground plane) tends to flow right under the signal trace. Breaks in the ground plane (as simple as through-hole leads and vias) increase the inductance of the plane, making it less effective at higher frequencies. Breaks in the ground plane for necessary vias should be spaced randomly.

Package information

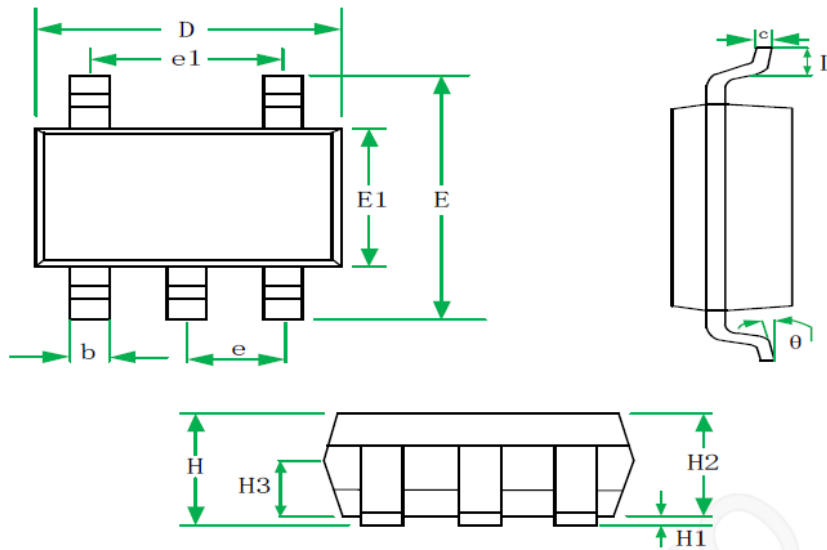

SYMBOL	MILLIMETERS			INCHES		
	MIN	NOM	MAX	MIN	NOM	MAX
H	1.07		1.25	0.042		0.049
H1	0.02	0.06	0.10	0.001	0.002	0.004
H2	1.05	1.10	1.15	0.041	0.043	0.045
H3	0.60	0.65	0.70	0.024	0.026	0.028
b	0.30	0.40	0.50	0.012	0.016	0.020
c	0.102	0.152	0.202	0.004	0.006	0.008
D	2.82	2.92	3.02	0.111	0.115	0.119
E	2.65	2.80	2.95	0.104	0.110	0.116
E1	1.50	1.60	1.70	0.059	0.063	0.067
e	0.95BSC			0.037BSC		
e1	1.90BSC			0.075BS		
L	0.30	0.40	0.50	0.012	0.016	0.020
θ	0		8°	0		8°

SOT23-5 for MX7219T

Restrictions on Product Use

- ◆ MAXIN micro is continually working to improve the quality and reliability of its products. Nevertheless, semiconductor devices in general can malfunction or fail due to their inherent electrical sensitivity and vulnerability to physical stress. It is the responsibility of the buyer, when utilizing MAXIN products, to comply with the standards of safety in making a safe design for the entire system, and to avoid situations in which a malfunction or failure of such MAXIN products could cause loss of human life, bodily injury or damage to property.
- ◆ In developing your designs, please ensure that MAXIN products are used within specified operating ranges as set forth in the most recent MAXIN products specifications.
- ◆ The information contained herein is subject to change without notice.

Version update record:

V10 The original version (preliminary)

Preliminary