

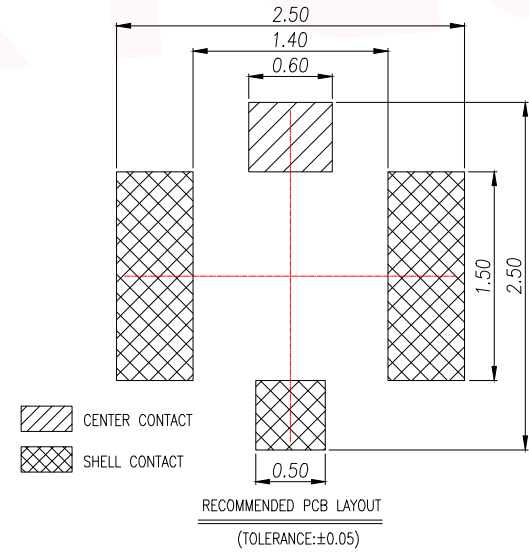

| | | | | |
|------|------|----------|------|------|
| REV. | Q'TY | ECN. NO. | APR. | DATE |
| | | | | |

PRELIMINARY
DESIGN IS SUBJECT
TO CHANGE WITHOUT
PRIOR NOTICE

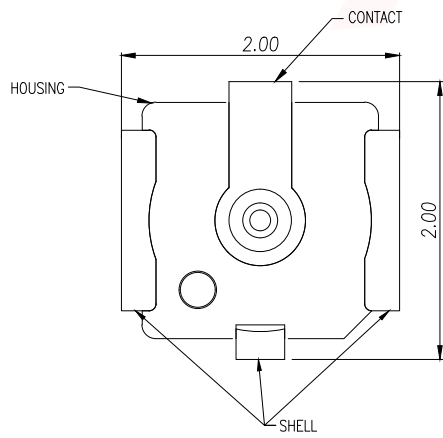
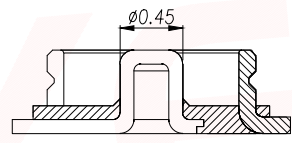
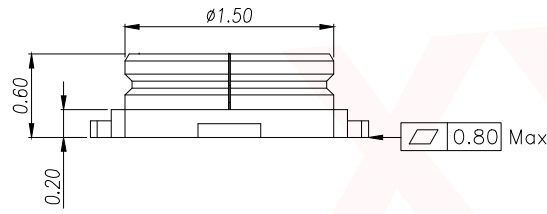
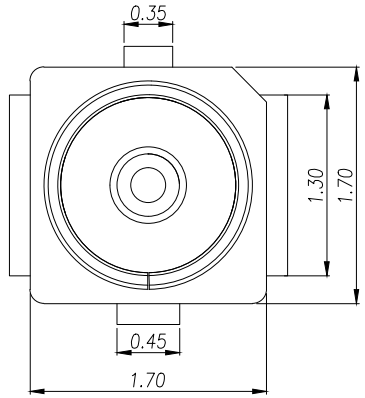

 CENTER CONTACT
 SHELL CONTACT

NOTES :

- 1.0. RATING :
 - 1.1. VOITAGE :60 VAC (R.M.S.)
 - 1.2. NOMINAL CHARACTERISTIC IMPEDANCE: 50 Ohm
 - 1.3. APPLICABLE FREQUENCY: DC ~ 6GHz
 - 1.4. VSWR: 1.3 MAX. (DC~3GHz), 1.5 MAX. (3~6GHz)
 - 1.5. TEMPERATURE :-40°C TO +85°C
- 2.0. ALL DIMENSIONS SHOULD BE CONTROLLED IN FAI.:
- 3.0. MARKED ∇^* SHOULD BE CONTROLLED BY QIP.:
- 4.0. MATERIAL SEE BILL OF MATERIAL :

| DIMENSION IN mm | | 厦门市辛译精密电子有限公司 Xiamen XinYi Xyconn Electronics Co.,Ltd | | |
|--------------------------------------|----------|--|------|--|
| TOLERANCE UNLESS OTHERWISE SPECIFIED | | APR. | Alex | TITLE: 无线座 四代座子 |
| .X±0.35 | X.*± 5* | CHK. | Jack | DWG NO. RF1-4D |
| .XX±0.25 | .X*± 3* | DRA. | Can | PROJ.  CUSTOMER DRAWING |
| .XXX±0.15 | .XX*± 1* | SIZE | A4 | SCALE 1:1 SHEET 1/3 REV. A |

| | | | | |
|------|------|----------|------|------|
| REV. | Q'TY | ECN. NO. | APR. | DATE |
| | | | | |

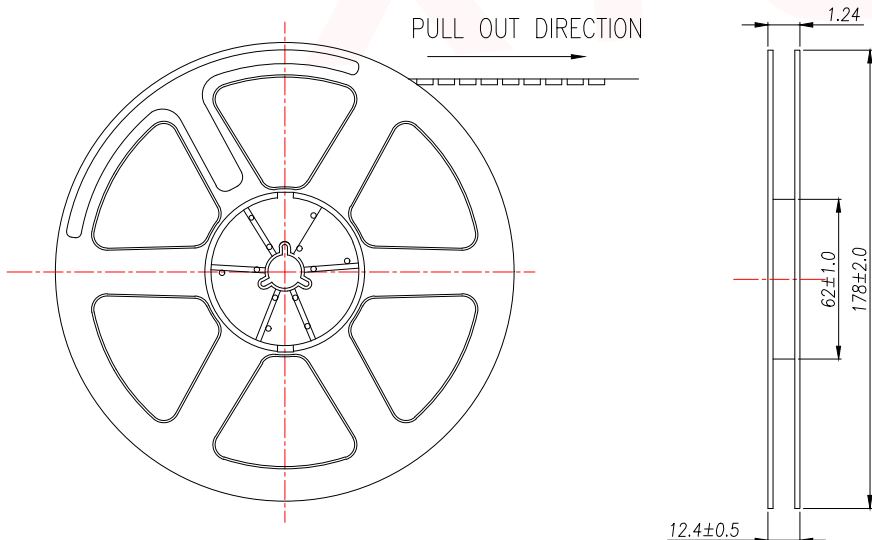
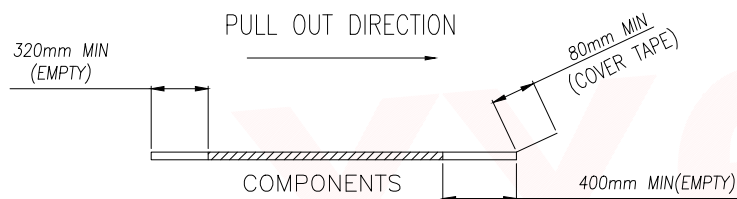
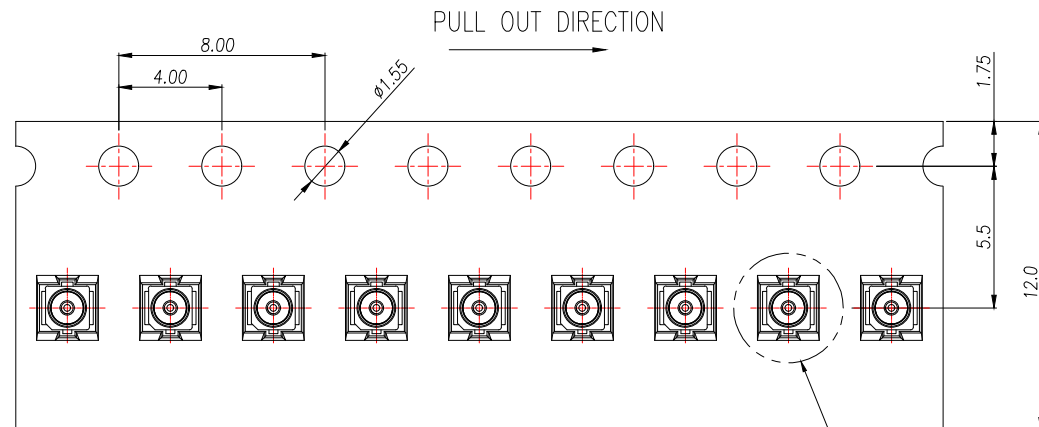

NOTES:

- MATERIAL :
 - EMBOSSED CARRIER: PET
 - COVER TAPE: PET
 - SHIPPING CARTON: CORRUGATED FIBER
- DIMENSION :
 - REEL: W=12.4
 - SHIPPING CARTON: L=190, W=190, H=190
- PEELING RESISTANCE: 10gf~130gf.
- QUANTITY/WEIGHT :

PRELIMINARY
DESIGN IS SUBJECT
TO CHANGE WITHOUT
PRIOR NOTICE

| PART NO. | PRIMARY PACKING | SECONDARY PACKING | NET WEIGHT | GROSS WEIGHT |
|---------------|-----------------|-------------------|-------------|--------------|
| MRFB04-B01100 | 3000PCS/REEL | 30000PCS/BOX | 0.17KG/REEL | 1.90KG/BOX |

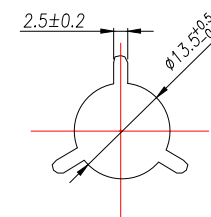
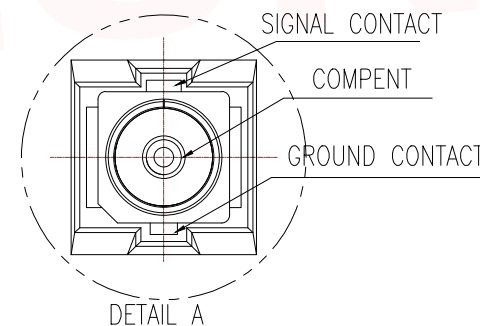

| DIMENSION IN mm | | 厦门市辛译精密电子有限公司 Xiamen XinYi Xyconn Electronics Co.,Ltd | | | |
|--------------------------------------|----------|--|-------|-------------------------|--------|
| TOLERANCE UNLESS OTHERWISE SPECIFIED | | APR. | Alex | TITLE: 无线座 四代座子 | |
| .X±0.35 | X.*± 5* | CHK. | Jack | DWG NO. RF1-4D | |
| .XX±0.25 | .X*± 3* | DRA. | Can | PROJ. CUSTOMER DRAWING | |
| .XXX±0.15 | .XX*± 1* | SIZE | A4 | SCALE | 1:1 |
| | | | SHEET | 2/3 | REV. A |

| | | | | |
|------|------|----------|------|------|
| REV. | Q'TY | ECN. NO. | APR. | DATE |
| | | | | |

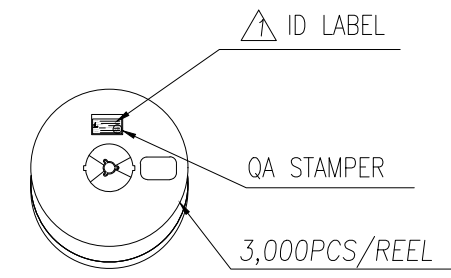

PRELIMINARY
DESIGN IS SUBJECT
TO CHANGE WITHOUT
PRIOR NOTICE

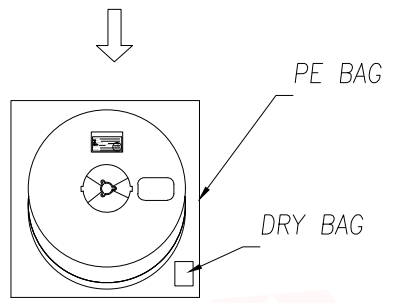

| | |
|------------------|------------------|
| 品名 NAME: | _____ |
| 料号 PART No.: | _____ |
| 客户料号 CLIENT P/N: | _____ |
| 客户订单 CLIENT PO#: | _____ |
| 数量 QTY: | _____ 重量 WEIGHT: |
| 批次 LOT No.: | _____ |
| 日期 DATE: | _____ |

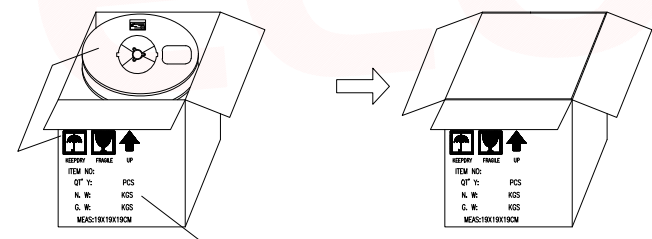
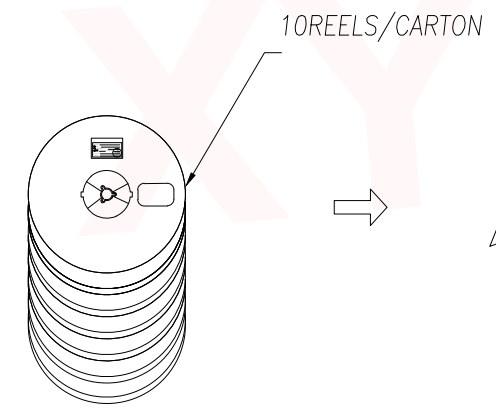

QTY: 30,000 PCS
N. W: 0.077 KGS
G. W: 1.033 KGS
MEAS: 19X19X19CM

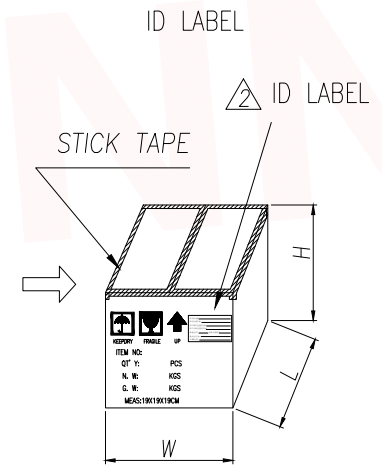

| | | | | |
|--------------------------------------|-----------|--|-----------|-------------------------|
| DIMENSION IN mm | | 厦门市辛译精密电子有限公司 Xiamen XinYi Xyconn Electronics Co.,Ltd | | |
| TOLERANCE UNLESS OTHERWISE SPECIFIED | | | | |
| .X±0.35 | X.*± 5* | APR. | Alex | TITLE: 无线座 四代座子 |
| .XX±0.25 | .X.*± 3* | CHK. | Jack | DWG NO. RF1-4D |
| .XXX±0.15 | .XX.*± 1* | DRA. | Can | PROJ. CUSTOMER DRAWING |
| | | SIZE A4 | SCALE 1:1 | SHEET 3/3 REV. A |