

REV.	Q'TY	ECN. NO.	APR.	DATE

PRELIMINARY  
DESIGN IS SUBJECT  
TO CHANGE WITHOUT  
PRIOR NOTICE

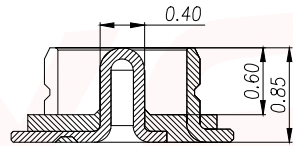

SECTION A-A

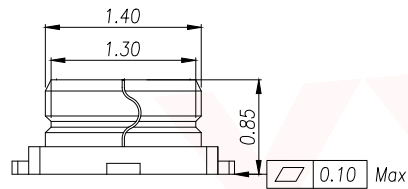
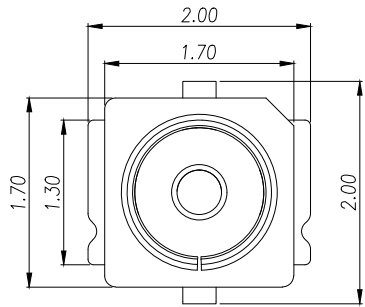
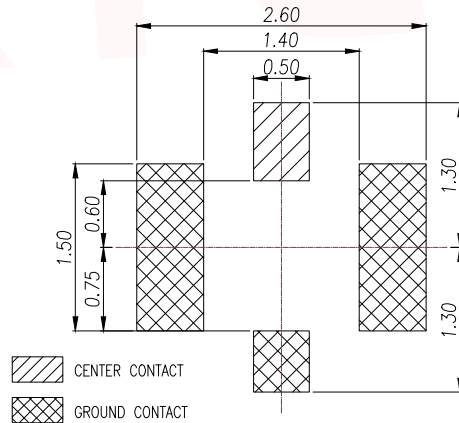
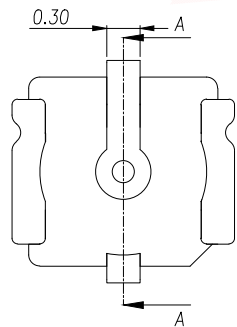

 CENTER CONTACT  
 GROUND CONTACT

RECOMMENDED PCB LAYOUT  
(TOLERANCE:±0.05)

NOTES :

- 1.0. RATING :
  - 1.1. VOLTAGE :60 VAC (R.M.S.)
  - 1.2. NOMINAL CHARACTERISTIC IMPEDANCE: 50 Ohm
  - 1.3. APPLICABLE FREQUENCY: DC ~ 6GHz
  - 1.4. VSWR: 1.3 MAX. (DC~3GHz), 1.5 MAX. (3~6GHz)
  - 1.5. TEMPERATURE :-40°C TO +85°C
- 2.0. ALL DIMENSIONS SHOULD BE CONTROLLED IN FAI.:
- 3.0. MARKED  $\nabla^*$  SHOULD BE CONTROLLED BY QIP.:
- 4.0. MATERIAL SEE BILL OF MATERIAL :

DIMENSION IN mm		厦门市辛译精密电子有限公司 Xiamen XinYi Xyecomm Electronics Co.,Ltd		
TOLERANCE UNLESS OTHERWISE SPECIFIED		APR.	Alex	TITLE: 无线座 三代座子
.X±0.35	X.*± 5*	CHK.	Jack	DWG NO. RF1-3D
.XX±0.25	.X*± 3*	DRA.	Can	PROJ.  CUSTOMER DRAWING
.XXX±0.15	.XX*± 1*	SIZE	A4	SCALE 1:1 SHEET 1/3 REV. A

REV.	Q'TY	ECN. NO.	APR.	DATE

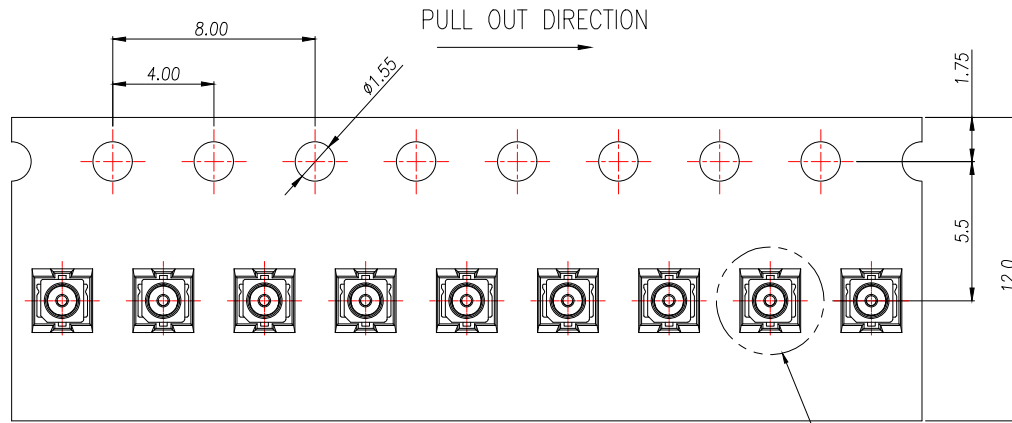

PRELIMINARY  
DESIGN IS SUBJECT  
TO CHANGE WITHOUT  
PRIOR NOTICE

NOTES:

- MATERIAL :
  - 1.1 EMBOSSED CARRIER: PET
  - 1.2 COVER TAPE: PET
  - 1.3 SHIPPING CARTON: CORRUGATED FIBER
- DIMENSION :
  - 2.1 REEL: W=12.4
  - 2.2 SHIPPING CARTON: L=190, W=190, H=190
- PEELING RESISTANCE: 10gf~130gf.
- QUANTITY/WEIGHT :

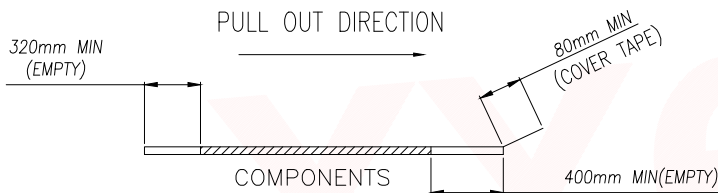

PART NO.	PRIMARY PACKING	SECONDARY PACKING	NET WEIGHT	GROSS WEIGHT
MRFB03-B01100	3000PCS/REEL	30000PCS/BOX	0.18KG/REEL	2.00KG/BOX

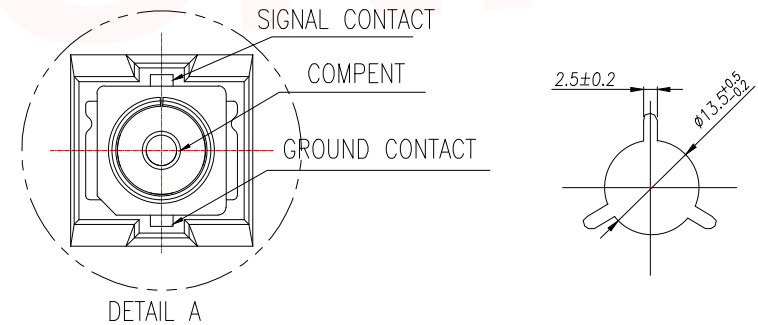
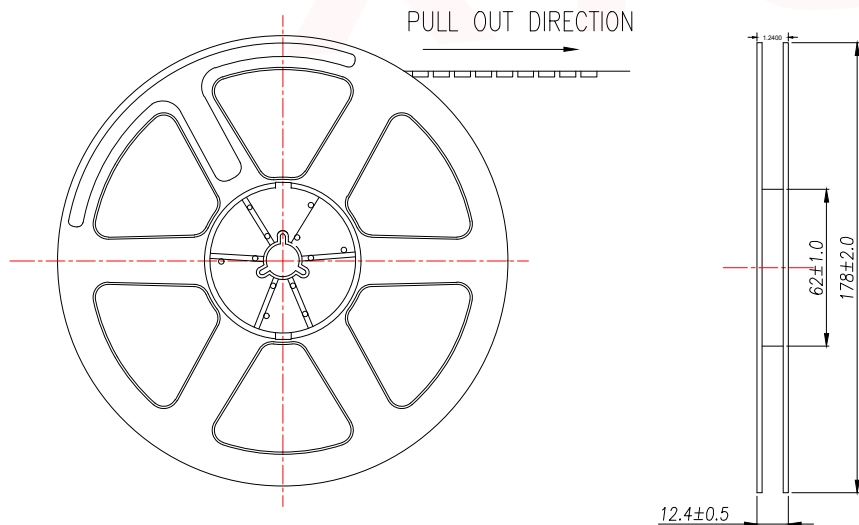

DIMENSION IN mm		厦门市辛译精密电子有限公司 Xiamen XinYi Xyconn Electronics Co.,Ltd		
TOLERANCE UNLESS OTHERWISE SPECIFIED		APR.	Alex	TITLE: 无线座 三伏座子
.X±0.35	X.*± 5*	CHK.	Jack	DWG NO. RF1-3D
.XX±0.25	.X*± 3*	DRA.	Can	PROJ.  CUSTOMER DRAWING
.XXX±0.15	.XX*± 1*	SIZE	A4	SCALE 1:1 SHEET 2/3 REV. A

REV.	Q'TY	ECN. NO.	APR.	DATE

PRELIMINARY  
DESIGN IS SUBJECT  
TO CHANGE WITHOUT  
PRIOR NOTICE

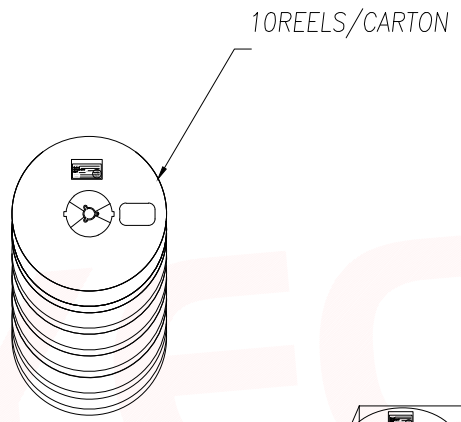
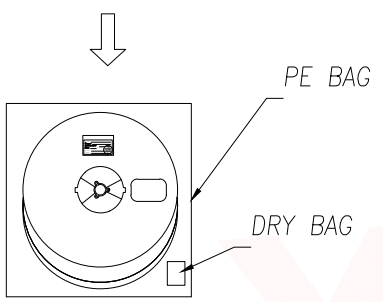
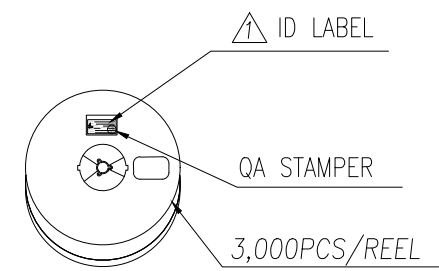

品名NAME: \_\_\_\_\_

料号 PART No: \_\_\_\_\_

客户料号 CUSTOMER PART No: \_\_\_\_\_

数量 Q'TY: \_\_\_\_\_ 重量WEIGHT: \_\_\_\_\_

批次 LOT No: \_\_\_\_\_

日期 DATE: \_\_\_\_\_

ID LABEL

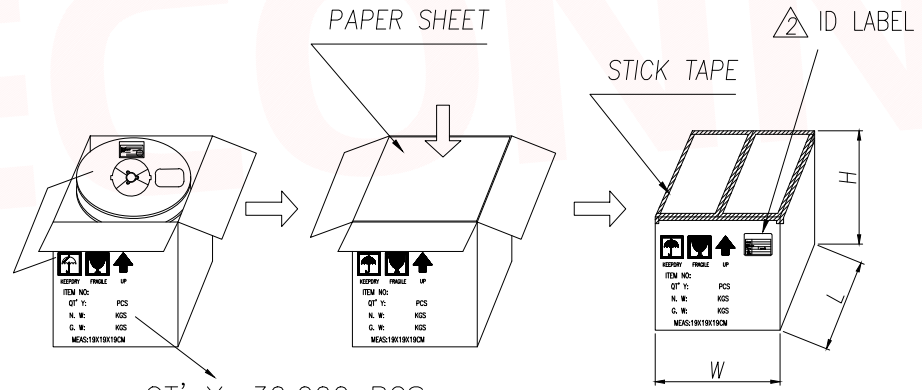
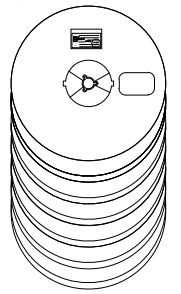

QT' Y: 30,000 PCS  
N. W: 1.76 KGS  
G. W: 2.0 KGS  
MEAS: 19X19X19CM

DIMENSION IN mm		厦门市辛译精密电子有限公司 Xiamen XinYi Xyconn Electronics Co.,Ltd		
TOLERANCE UNLESS OTHERWISE SPECIFIED				
.X±0.35	X.*± 5*	APR.	Alex	TITLE: 无线座 三代座子
.XX±0.25	.X.*± 3*	CHK.	Jack	DWG NO. RF1-3D
.XXX±0.15	.XX.*± 1*	DRA.	Can	PROJ.  CUSTOMER DRAWING
		SIZE A4	SCALE 1:1	SHEET 3/3 REV. A