

## ■ FEATURE

- ◆ 30V/6.0A,  $R_{DS(ON)}=18m\Omega$  (typ.)@ $V_{GS}=10V$
- ◆ 30V/4.8A,  $R_{DS(ON)}=25m\Omega$  (typ.)@ $V_{GS}=4.5V$
- ◆ Super high design for extremely low  $R_{DS(ON)}$
- ◆ Exceptional on-resistance and Maximum DC current capability
- ◆ Full RoHS compliance
- ◆ SOT23-3L package design

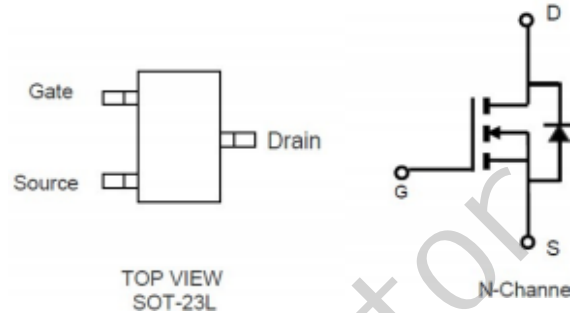

## ■ DESCRIPTION

The 3404 is the N-Channel logic enhancement mode power field effect transistor is produced using high cell density advanced trench technology..

This high density process is especially tailored to minimize on-state resistance. These devices are particularly suited for low voltage application, and low in-line power loss are needed in a very small outline surface mount package.

## ■ APPLICATIONS

- ◆ Power Management
- ◆ Portable Equipment
- ◆ DC/DC Converter
- ◆ Load Switch
- ◆ DSC

## ■ ABSOLUTE MAXIMUM RATINGS ( $T_A = 25^\circ C$ Unless otherwise noted )

Symbol	Parameter		Typical	Unit
$V_{DSS}$	Drain-Source Voltage		30	V
$V_{GSS}$	Gate-Source Voltage		$\pm 20$	V
$I_D$	Continuous Drain Current ( $T_C=25^\circ C$ )	$V_{GS}=10V$	6.0	A
	Continuous Drain Current ( $T_C=70^\circ C$ )		5.0	
$I_{DM}$	Pulsed Drain Current		20	A
$I_S$	Continuous Source Current (Diode Conduction)		1.5	A
$P_D$	Power Dissipation	$T_A=25^\circ C$	1.5	W
		$T_A=70^\circ C$	0.9	
$T_J$	Operation Junction Temperature		150	$^\circ C$
$T_{STG}$	Storage Temperature Range		-55~+150	$^\circ C$
$R_{\theta JA}$	Thermal Resistance Junction to Ambient		90	$^\circ C/W$

**Note: Absolute maximum ratings are those values beyond which the device could be permanently damaged.**

**Absolute maximum ratings are stress rating only and functional device operation is not implied**

**■ ELECTRICAL CHARACTERISTICS** ( $T_A=25^\circ\text{C}$  Unless otherwise noted)

Symbol	Parameter	Condition	Min	Typ	Max	Unit
<b>Static Parameters</b>						
$V_{(BR)DSS}$	Drain-Source Breakdown Voltage	$V_{GS}=0V, I_D=250\mu A$	30			V
$V_{GS(th)}$	Gate Threshold Voltage	$V_{DS}=V_{GS}, I_D=250\mu A$	1		2	V
$I_{GSS}$	Gate Leakage Current	$V_{DS}=0V, V_{GS}=\pm 20V$			$\pm 100$	nA
$I_{DSS}$	Zero Gate Voltage Drain Current	$V_{DS}=24V, V_{GS}=0$			1	uA
		$V_{DS}=24V, V_{GS}=0$ $T_J=55^\circ\text{C}$			5	
$R_{DS(ON)}$	Drain-Source On-Resistance	$V_{GS}=10V, I_D=6.0A$		18	30	m $\Omega$
		$V_{GS}=4.5V, I_D=4.8A$		25	40	
<b>Source-Drain Diode</b>						
$V_{SD}$	Diode Forward Voltage	$I_S=1.0A, V_{GS}=0V$		0.7	1.0	V
<b>Dynamic Parameters</b>						
$Q_g$	Total Gate Charge	$V_{DS}=20V$ $V_{GS}=4.5V$ $I_D=6.0A$		6		nC
$Q_{gs}$	Gate-Source Charge			1.1		
$Q_{gd}$	Gate-Drain Charge			2.5		
$C_{iss}$	Input Capacitance	$V_{DS}=15V$ $V_{GS}=0V$ $f=1\text{MHz}$		414		pF
$C_{oss}$	Output Capacitance			60		
$C_{rss}$	Reverse Transfer Capacitance			49		
$T_{d(on)}$	Turn-On Time	$V_{DS}=15V$ $I_D=5A$		7.5		nS
$T_r$				45		
$T_{d(off)}$	Turn-Off Time	$V_{GEN}=10V$ $R_G=3.3\Omega$		10		
$T_f$				4		

**Note: 1. Pulse test: pulse width $\leq 300\mu\text{s}$ , duty cycle $\leq 2\%$**

**2. Static parameters are based on package level with recommended wire bonding**

■ **TYPICAL CHARACTERISTICS** (25°C Unless Note)

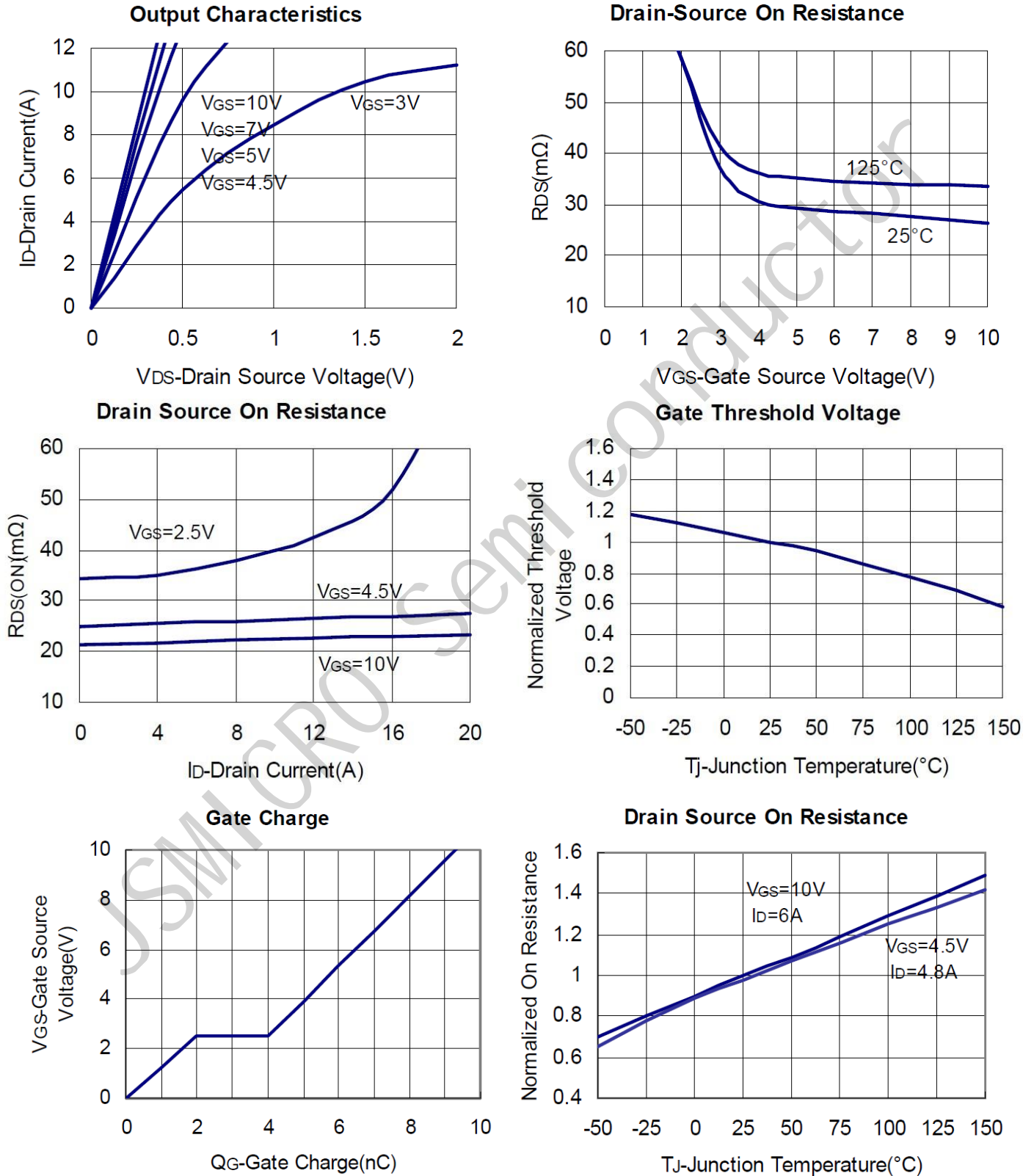

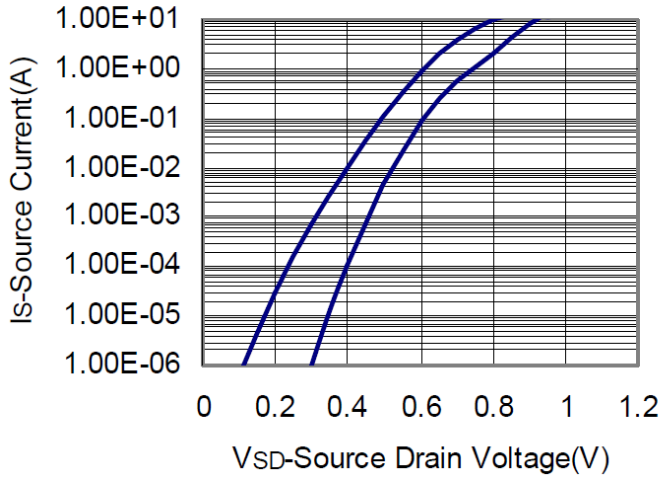
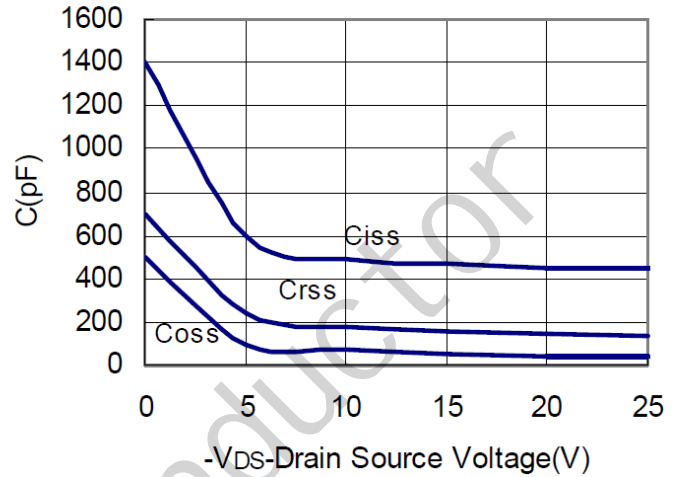
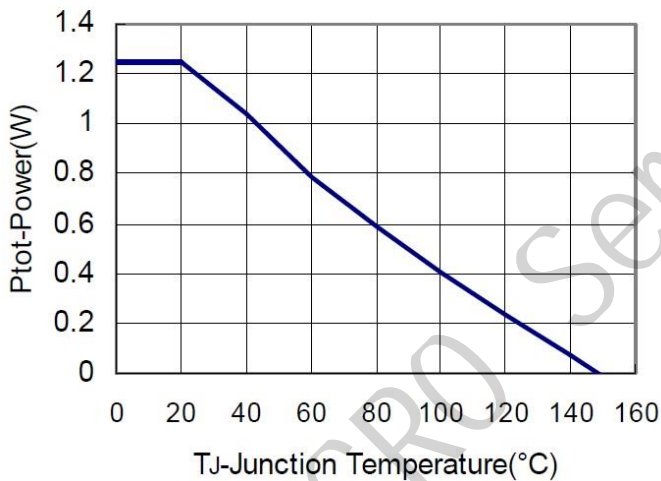
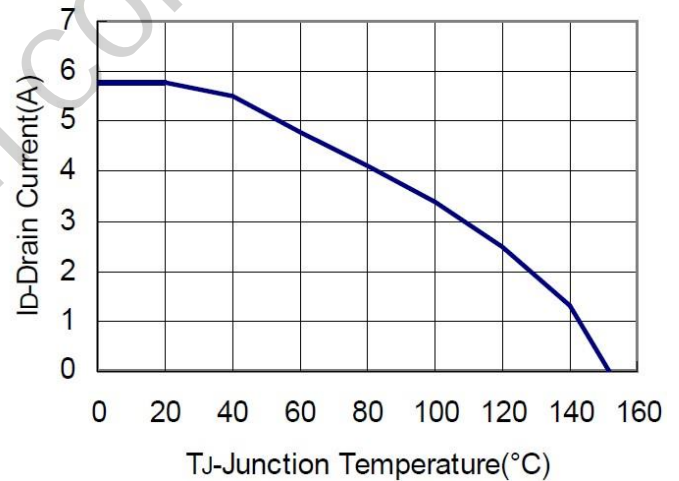
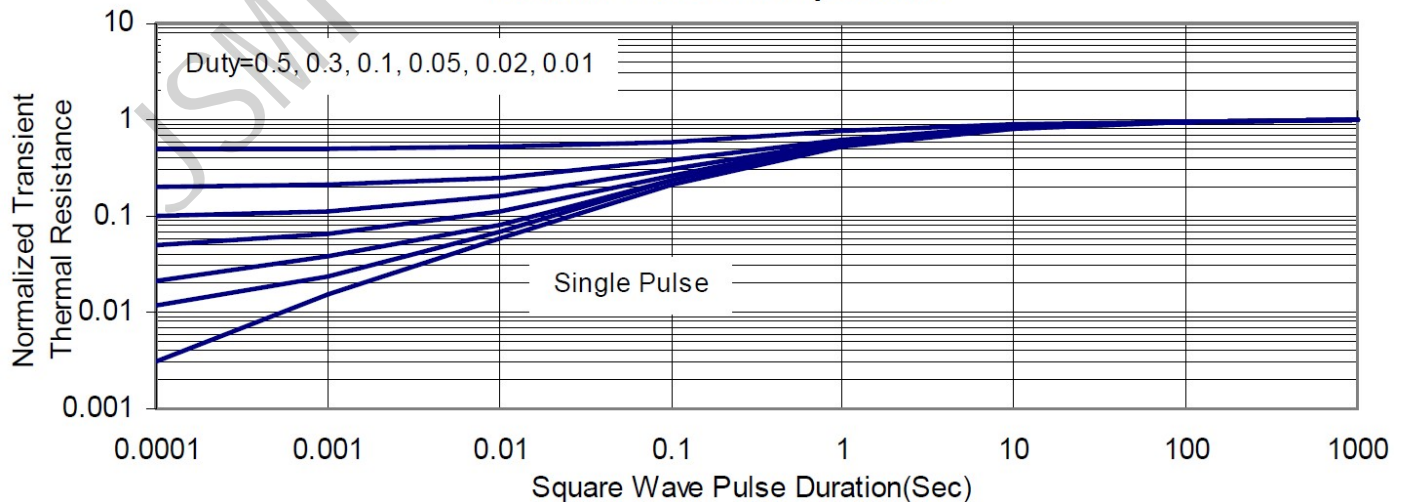
**TYPICAL CHARACTERISTICS (continuous)**
**Source Drain Diode Forward**

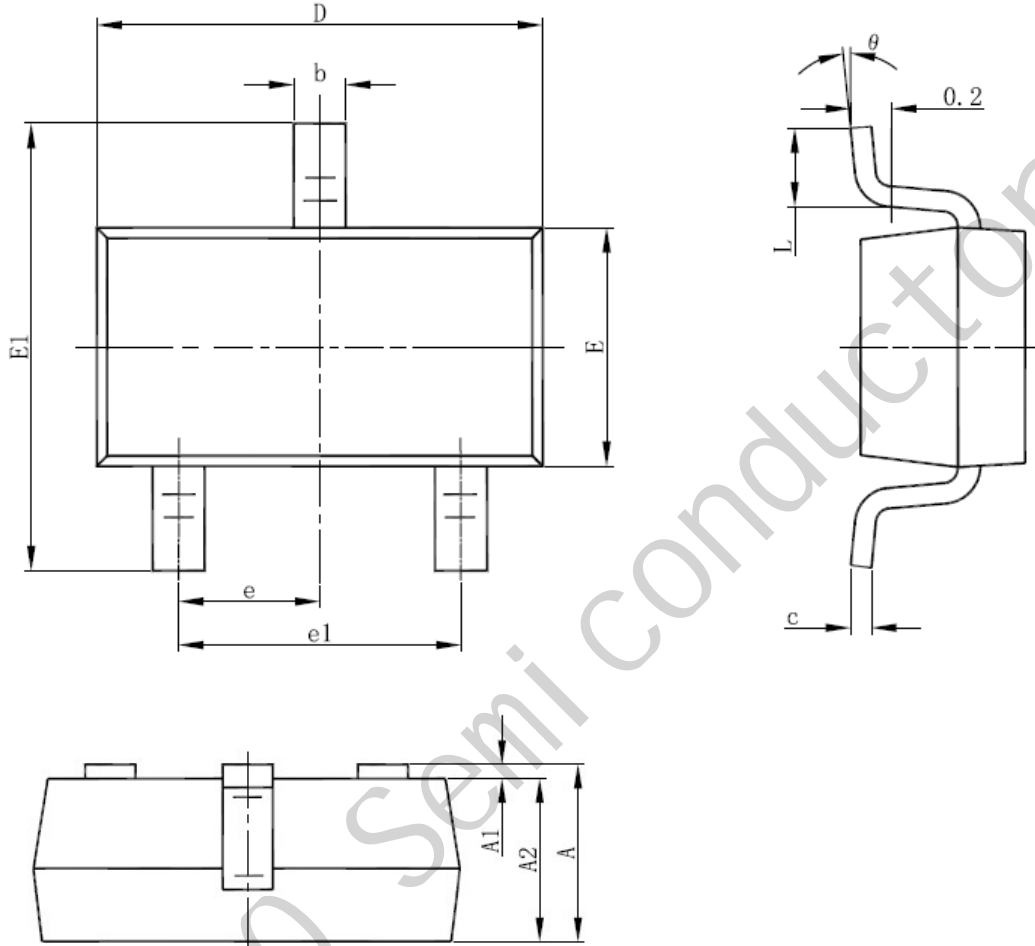
**Capacitance**

**Power Dissipation**

**Drain Current**

**Thermal Transient Impedance**

**■ SOT23-3L PACKAGE OUTLINE DIMENSIONS**

Symbol	Dimensions In Millimeters		Dimensions In Inches	
	Min	Max	Min	Max
A	1.050	1.250	0.041	0.049
A1	0.000	0.100	0.000	0.004
A2	1.050	1.150	0.041	0.045
b	0.300	0.500	0.012	0.020
c	0.100	0.200	0.004	0.008
D	2.820	3.020	0.111	0.119
E	1.500	1.700	0.059	0.067
E1	2.650	2.950	0.104	0.116
e	0.950(BSC)		0.037(BSC)	
e1	1.800	2.000	0.071	0.079
L	0.300	0.600	0.012	0.024
theta	0°	8°	0°	8°