

■ Features

- The plastic material used carries Underwriters Laboratory flammability recognition 94V-0
- Surge overload ratings to 30 amperes
- Ideal for printed circuit board application
- High temperature soldering guaranteed 260 °C/5 seconds at 5 lbs (2.3kg) tension

■ Mechanical Data

- Case: Reliable low cost construction utilizing molded plastic technique
- Terminals: Plated leads solderable per MIL-STD-202, Method 208
- Mounting Position: Any

■ Maximum Ratings & Thermal Characteristics

Parameter	Symbol	DB101S	DB102S	DB103S	DB104S	DB105S	DB106S	DB107S	Unit
Maximum repetitive peak reverse voltage	V_{RRM}	50	100	200	400	600	800	1000	V
Maximum RMS bridge input voltage	V_{RMS}	35	70	140	280	420	560	700	V
Maximum DC blocking voltage	V_{DC}	50	100	200	400	600	800	1000	V
Maximum average forward rectified output current at $T_A=40^{\circ}C$	$I_{F(AV)}$	1.0							A
Peak forward surge current single sine-wave superimposed on rated load (JEDEC Method)	I_{FSM}	30							A
Rating for fusing ($t < 8.3ms$)	i^2t	3.735							$A^2 sec$
Typical thermal resistance per element (1)	$R_{\theta JA}$	110							$^{\circ}C/W$
Typical junction capacitance per element (2)	C_J	25.0							pF
Operating junction and storage temperature range	T_J T_{STG}	-55 to + 150							$^{\circ}C$

Notes: Rating at 25 °C ambient temperature unless otherwise specified, Resistive or Inductive load, 60 Hz. For Capacitive load derate current by 20%.

■ Electrical Characteristics

CHARACTERISTICS	SYMBOL	DB101S	DB102S	DB103S	DB104S	DB105S	DB106S	DB107S	UNIT
Maximum instantaneous forward voltage drop per leg at 1.0A	V_F	1.1							V
Maximum DC Reverse Current at Rated DC Blocking Voltage	I_R	10 500							μA

Notes: Rating at 25 °C ambient temperature unless otherwise specified, Resistive or Inductive load, 60 Hz. For Capacitive load derate current by 20%.

Thermal resistance from Junction to Ambient on P.C.board mounting.

Measured at 2.0MHz and applied reverse voltage of 4.0 volts.

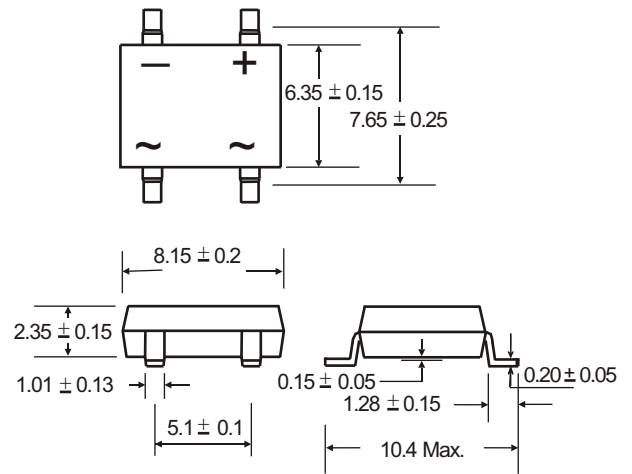
DB-S

Dimensions in inches and (millimeters)



■ Rating and Characteristic Curves ($T_A=25^{\circ}\text{C}$ Unless otherwise noted)

Fig. 1 Derating Curve for Output Rectified Current

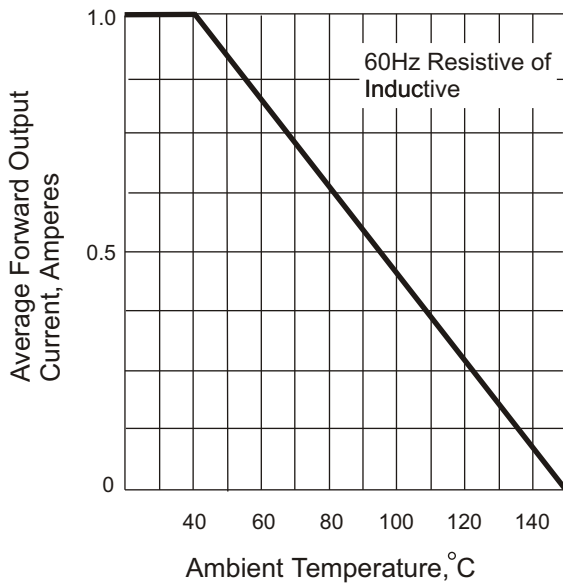

Fig. 2 Maximum Non-repetitive Peak Forward Surge Current

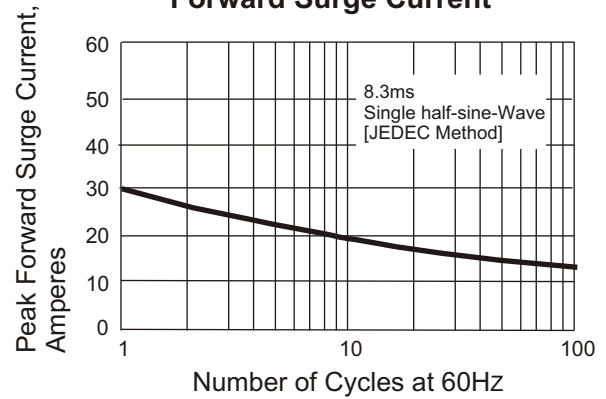

Fig. 3 Typical Instantaneous Forward Characteristics

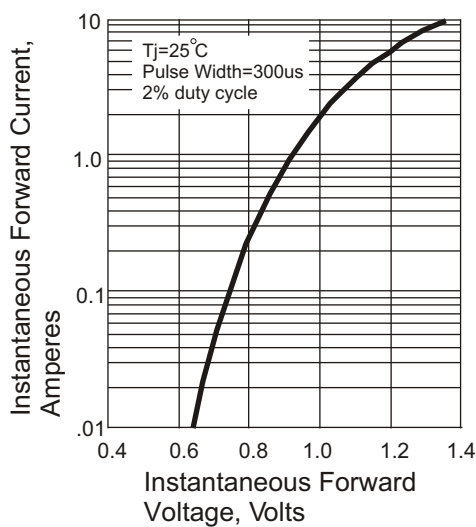

Fig. 4 Typical Revers Characteristics

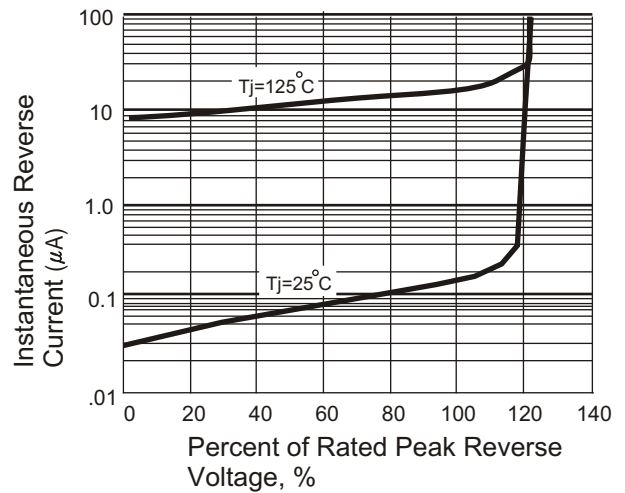

Fig. 5 Typical Junction Capacitance

