



T-46-09-05

54LS395/DM74LS395

4-Bit Shift Register with TRI-STATE® Outputs

General Description

The LS395 is a 4-bit shift register with TRI-STATE outputs and can operate in either a synchronous parallel load or a serial shift-right mode, as determined by the Select input. An asynchronous active LOW Master Reset (\overline{MR}) input overrides the synchronous operations and clears the register. An active LOW Output Enable (\overline{OE}) input controls the TRI-STATE output buffers, but does not interfere with the other operations. The fourth stage also has a conventional output for linking purposes in multi-stage serial operations.

Features

- Shift right or parallel 4-bit register
- TRI-STATE outputs
- Input clamp diodes limit high speed termination effects
- Fully CMOS and TTL compatible

Connection Diagram

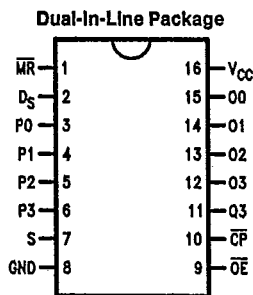

Logic Symbol

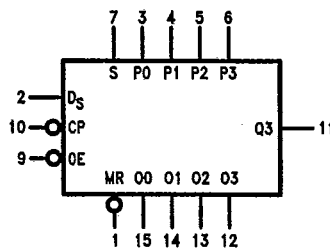

V_{CC} = Pin 16
GND = Pin 8

TL/F/9833-2

Order Number 54LS395DMQB, 54LS395FMQB,
54LS395LMQB, DM74LS395WM or DM74LS395N
See NS Package Number
E20A, J16A, M16B, N16E or W16A

TL/F/9833-1

Mode Select Table

Operating Mode	Inputs @ t_n					Outputs @ t_{n+1}			
	\overline{MR}	\overline{CP}	S	D_S	P_n	O0	O1	O2	O3
Asynchronous Reset	L	X	X	X	X	L	L	L	L
Shift, SET First Stage	H		L	H	X	H	O0 _n	O1 _n	O2 _n
Shift, RESET First Stage	H		L	L	X	L	O0 _n	O1 _n	O2 _n
Parallel Load	H		H	X	P_n	P0	P1	P2	P3

t_n, t_{n+1} = Time before and after CP HIGH-to-LOW transition
H = HIGH Voltage Level
L = LOW Voltage Level
X = Immaterial



LS395

Absolute Maximum Ratings (Note)

T-46-09-05

If Military/Aerospace specified devices are required, please contact the National Semiconductor Sales Office/Distributors for availability and specifications.

Note: The "Absolute Maximum Ratings" are those values beyond which the safety of the device cannot be guaranteed. The device should not be operated at these limits. The parametric values defined in the "Electrical Characteristics" table are not guaranteed at the absolute maximum ratings. The "Recommended Operating Conditions" table will define the conditions for actual device operation.

Supply Voltage	7V
Input Voltage	10V
Operating Free Air Temperature Range	
54LS	-55°C to +125°C
DM74LS	0°C to +70°C
Storage Temperature Range	-65°C to +150°C

Recommended Operating Conditions

Symbol	Parameter	54LS395			DM74LS395			Units
		Min	Nom	Max	Min	Nom	Max	
V _{CC}	Supply Voltage	4.5	5	5.5	4.75	5	5.25	V
V _{IH}	High Level Input Voltage	2			2			V
V _{IL}	Low Level Input Voltage			0.7			0.8	V
I _{OH}	High Level Output Current			-0.4			-0.4	mA
I _{OL}	Low Level Output Current			4			8	mA
T _A	Free Air Operating Temperature	-55		125	0		70	°C
t _s (H)	Setup Time HIGH or LOW	20			20			ns
t _s (L)	S, D _S or P _n to CP	20			20			ns
t _h (H)	Hold Time HIGH or LOW	5			5			ns
t _h (L)	S, D _S or P _n to CP	5			5			ns
t _w (L)	CP Pulse Width LOW	18			18			ns
t _w (L)	MR Pulse Width LOW	20			20			ns

Electrical Characteristics Over recommended operating free air temperature range (unless otherwise noted)

Symbol	Parameter	Conditions	Min	Typ (Note 1)	Max	Units
V _I	Input Clamp Voltage	V _{CC} = Min, I _I = -18 mA			-1.5	V
V _{OH}	High Level Output Voltage	V _{CC} = Min, I _{OH} = Max V _{IL} = Max	54LS 2.5 DM74 2.7			V
V _{OL}	Low Level Output Voltage	V _{CC} = Min, I _{OL} = Max V _{IH} = Min	54LS DM74		0.4 0.35 0.5	V
		I _{OL} = 4 mA, V _{CC} = Min	DM74		0.25 0.4	
I _I	Input Current @ Max Input Voltage	V _{CC} = Max, V _I = 10V			0.1	mA
I _{IH}	High Level Input Current	V _{CC} = Max, V _I = 2.7V			20	μA
I _{IL}	Low Level Input Current	V _{CC} = Max, V _I = 0.4V			-0.4	mA
I _{OS}	Short Circuit Output Current	V _{CC} = Max (Note 2)	54LS -20 DM74 -20		-100 -100	mA
I _{CC}	Supply Current with Outputs OFF	V _{CC} = Max, OE, D _S , S = 4.5V CP = , P _n = GND			29	mA
	Supply Current with Outputs ON	V _{CC} = Max, D _S , S = 4.5V OE, CP, P _n = GND			25	mA
I _{OZH}	TRI-STATE Output Off Current HIGH	V _{CC} = V _{CCH} V _{OZH} = 2.7V			20	μA
I _{OZL}	TRI-STATE Output Off Current LOW	V _{CC} = V _{CCH} V _{OZL} = 0.4V			-20	μA

Note 1: All typicals are at V_{CC} = 5V, T_A = 25°C.
 Note 2: Not more than one output should be shorted at a time, and the duration should not exceed one second.

Switching Characteristics

V_{CC} = +5.0V, T_A = +25°C (See Section 1 for waveforms and load configurations)

T-46-09-05

Symbol	Parameter	54LS/DM74LS		
		R _L = 2 kΩ, C _L = 15 pF		
		Min	Max	
f _{max}	Maximum Shift Frequency	30		MHz
t _{PLH} t _{PHL}	Propagation Delay CP̄ to O _n		35 25	ns
t _{PHL}	Propagation Delay MR to O _n		35	ns
t _{PZH} t _{PZL}	Output Enable Time		20 20	ns
t _{PHZ} t _{PLZ}	Output Disable Time		17 23	ns

Functional Description

The LS395 contains four D-type edge-triggered flip-flops and auxiliary gating to select a D input either from a Parallel (P_n) input or from the preceding stage. When the Select input is HIGH, the P_n inputs are enabled. A LOW signal in the S input enables the serial inputs for shift-right operations, as indicated in the Truth Table.

State changes are initiated by HIGH-to-LOW transitions on the Clock Pulse (CP̄) input. Signals on the P_n, D_S and S inputs can change when the Clock is in either state, provided that the recommended setup and hold times are observed.

When the S input is LOW, a CP̄ HIGH-LOW transition transfers data in O0 to O1, O1 to O2, and O2 to O3. A left-shift is accomplished by connecting the outputs back to the P_n inputs, but offset one place to the left, i.e., O3 to P2, O2 to P1, and O1 to P0, with P3 acting as the linking input from another package.

When the OĒ input is HIGH, the output buffers are disabled and the O0-O3 outputs are in a high impedance condition. The shifting, parallel loading or resetting operations can still be accomplished, however.

Logic Diagram

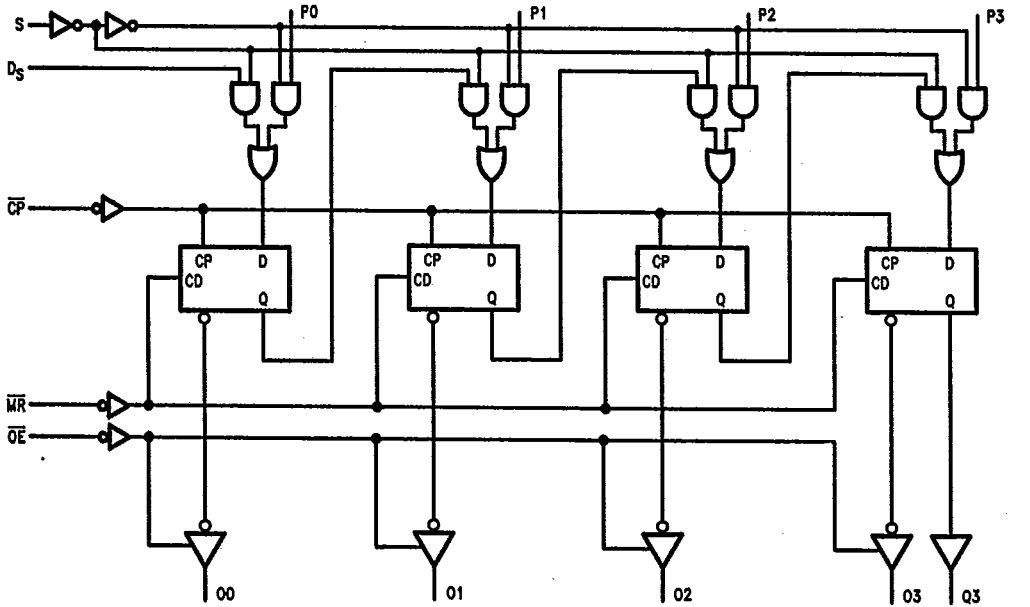

TL/F/9833-3

