

RECOMMENDED P.C.B. LAYOUT
TOLERANCE UNSPECIFIED ±0.05mm

REV.	DESCRIPTION OF REVISIONS	APPR.	CHKD.	DRAW.	DATE
△	Original reversion	lucky	lucky	Roy	2019/08/10
△	Add product model	lucky	lucky	Roy	2020/03/19
△	Delete Model No. U20405-2	lucky	lucky	Roy	2020/10/20
△	Change product model No.	lucky	lucky	Roy	2023/10/25

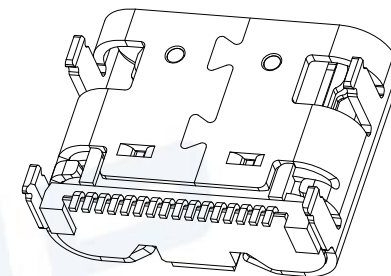

NOTE:

- MECHANICAL:
 - 1-1 Insertion force: 5~20N
 - 1-2 Extraction force: 8~20N
 - Extraction force: 10000 CYCLES 6~20N
 - 1-3.FREQUENCY:500±50 CYCLES/HOUR,10000 CYCLES;
- ELECTRICAL CHARACTERISTICS:
 - 2-1. CURRENT RATING:
 - VBUS Pins (A4,A9,B4,B9): 5A Max;
 - 1.25 Amps MAX. for Vconn (B5 of plug) with return path through the corresponding GND pins(Pin A1, A12, B1, B12). Other All Pins 0.25A/Pin
 - 2-2. INITIAL CONTACT RESISTANCE:40mΩ Max.
 - 2-3. INSULATION RESISTANCE:100MΩ MIN
 - 2-4. WITHSTANDING VOLTAGE:100V AC,1 MINUTE;
- ENVIRONMENTAL
 - TEMPERATURE RANGE: -40°C TO +85°C.

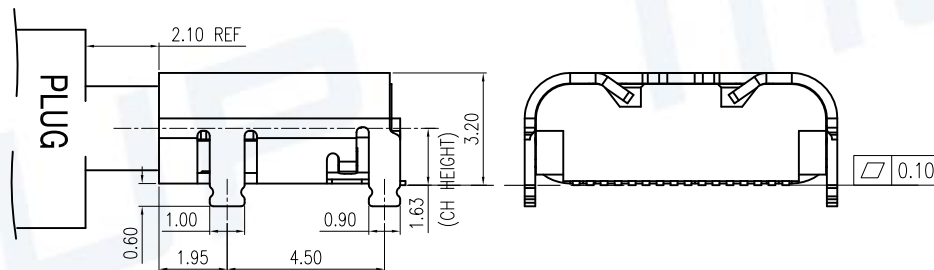
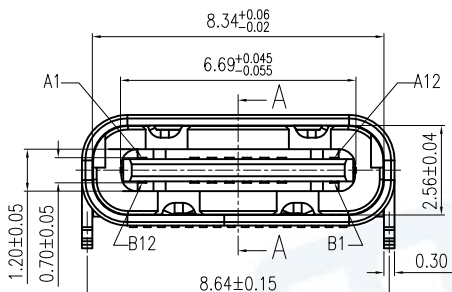

Model No.	Contact plating
MUP-U20405-01	Au: 3u"
MUP-U20405-03	Au: 1u"

ITEM	PART NAME	Q'TY	MATERIAL	FINISH
1	Molding	1	THERMOPLASTIC	Black, UL94V-0
2	CONTACT	16	HIGH CONDUCTIVITY COPPER	Contact area: Au 1u"/3u"
3	SHELL	1	STAINLESS STEEL	Ni plated over all
4	MID-PLATE	1	STAINLESS STEEL	RINSE

Unless otherwise specified, other tolerance are:

MUP MUP INDUSTRIAL CO.,LTD.

X ±0.40	X* ±5*	NAME: USB Type C SINGLE-Row SMT Receptacle
X.X ±0.30	X.X* ±4*	MODEL NO: MUP-U20405-XX
X.XX ±0.20	X.XX* ±3*	TYPE: 16Pin & Without Post on board L=6.90
X.XXX ±0.10	X.XXX* ±2*	
PROJ.	UNIT mm	SCALE 1:1
CUSTOMER DRAWING		
DRAW	Roy 2019/08/10	DWG NO.: DWG-U20405-XX-01
CHECKED	lucky 2019/08/10	SHEET 1/2
APPROVAL	lucky 2019/08/10	REVISION 4

A1	GND	B12	GND
A4	VBUS	B9	VBUS
A5	CC1	B8	SBU2
A6	DP1	B7	DN2
A7	DN1	B6	DP2
A8	SBU1	B5	CC2
A9	VBUS	B4	VBUS
A12	GND	B1	GND
PIN	SIGNAL NAME	PIN	SIGNAL NAME

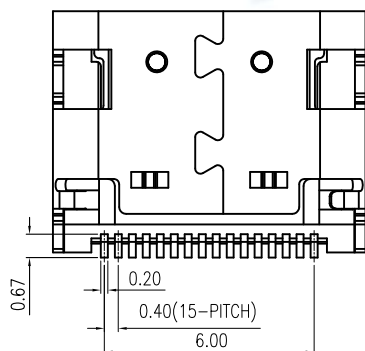

REV.	DESCRIPTION OF REVISIONS	APPR.	CHKD.	DRAW.	DATE
△	Original reversion	lucky	lucky	Roy	2019/08/10
△	Add product model	lucky	lucky	Roy	2020/03/19
△	Delete Model No. U20405-2	lucky	lucky	Roy	2020/10/20
△	Change product model No.	lucky	lucky	Roy	2023/10/25

NOTES

1. NUMBER OF CONNECTORS:1200PCS/REEL
2. LEAD TAPE LENGTH

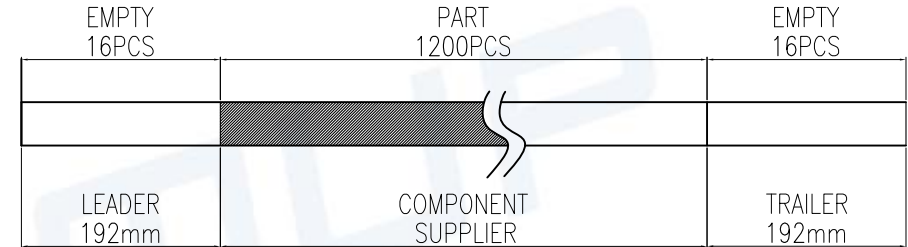

3. QUANTITY:12000/CARTON
4. WEIGHT :
 - 4.1 NET WEIGHT : 5.0 Kg
 - 4.2 GROSS WEIGHT : 10.3 Kg
5. Meas:350Lx350Wx315H mm

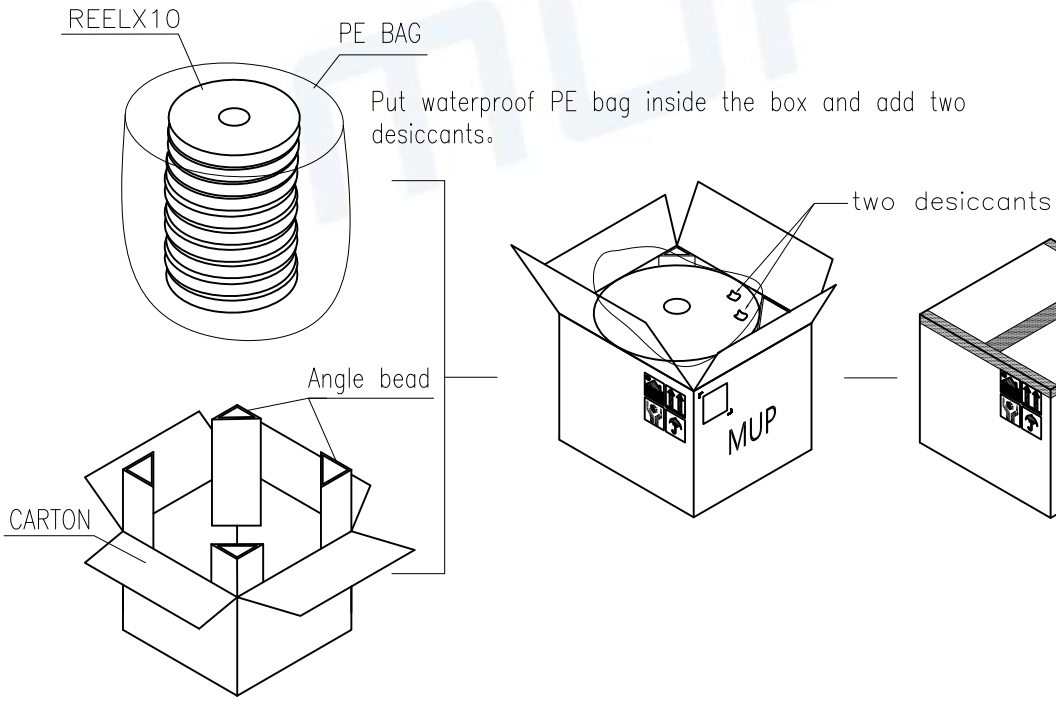
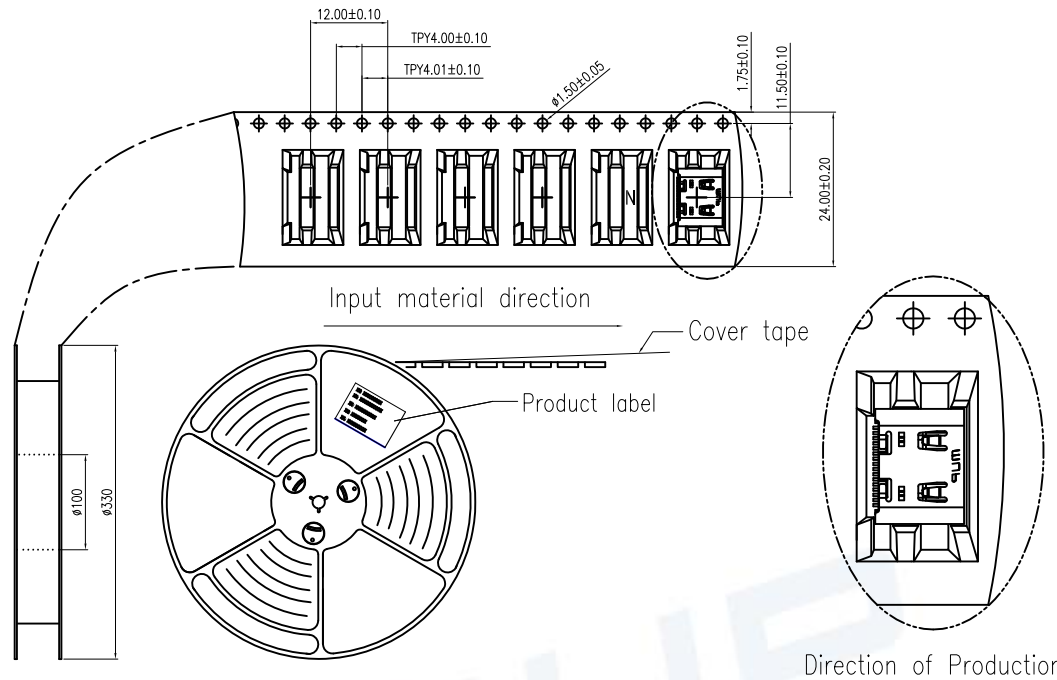

Unless otherwise specified, other tolerance are:		MUP MUP INDUSTRIAL CO.,LTD.			
X ±0.40	X* ±5*	NAME: USB Type C SINGLE-Row SMT Receptacle			
X.X ±0.30	X.X* ±4*	MODEL NO: MUP-U20405-XX			
X.XX ±0.20	X.XX* ±3*	TYPE : 16Pin & Without Post on board L=6.90			
X.XXX ±0.10	X.XXX* ±2*	PROJ.	UNIT	SCALE	DRAW
		mm	1:1	Roy 2019/08/10	DWG NO.: DWG-U20405-XX-01
CUSTOMER DRAWING		CHECKED	APPROVAL	lucky 2019/08/10	SHEET 2/2
				lucky 2019/08/10	REVISION 4