

**TUNING FORK CRYSTAL UNIT IN SMD 7.0x1.5mm RESIN MOLD PACKAGE.**
**PRODUCT FEATURES**

- Package dimensions 7.0x1.5x1.4 with 4 J-leads.
- Reliable resin mold SMD package suitable for SMT.
- Heat resistant mold allowing high temperature reflow.
- Suitable for low power consumption applications.
- RoHS compliant by exemption.

**APPLICATIONS**

- Real time clocks
- Microprocessors
- Timers and controllers
- Meters and handheld devices

**PRODUCT PHOTO (NOT IN SCALE)**

**PRODUCT SPECIFICATIONS**

PARAMETER	3607S	CONDITIONS / REMARKS
Nominal frequency range	32.768kHz	--
Vibration mode	Fundamental	--
Frequency tolerance	±20ppm / ±30ppm	Other options available.
Stability over temperature	-0.04ppm/°C <sup>2</sup> MAX	Parabolic coefficient.
Operating temperature range	-20 to +70°C or -40 to +85°C	Other options available.
Turnover temperature	+25±5°C	--
Equivalent series resistance (ESR)	<65kΩ	@ series load
Shunt capacitance	0.8pF	--
Motional capacitance	1.9fF	--
Load capacitance	7pF / 9pF / 12.5pF	Please specify.
Drive level	0.1μW TYP / 1.0μW MAX	--
Aging per year	±3ppm	At +25°C

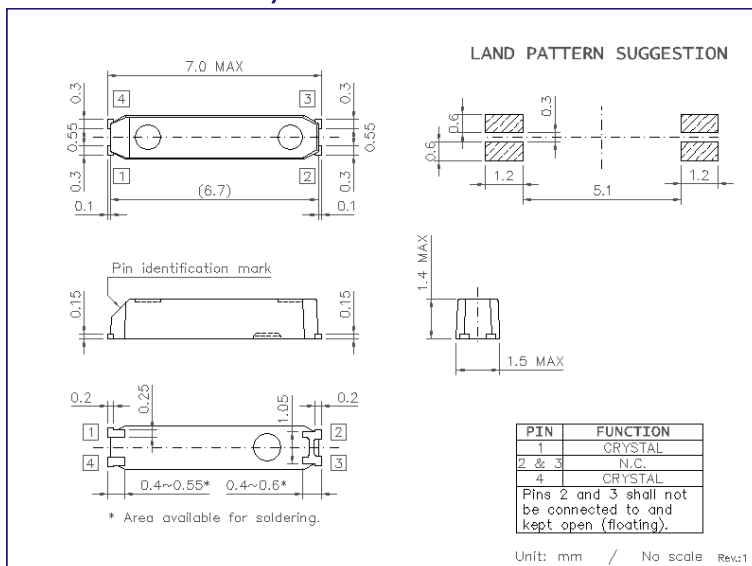
**PACKAGE OUTLINE / DIMENSIONS**

**PACKAGING INFORMATION**

- Tape & Reel compliant to EIA-481.
- Embossed carrier width 16mm.
- Component pitch in carrier 8mm.
- Reel diameter 330mm.
- QTY per reel: 3,000pcs

**RECOMMENDED REFLOW PROFILE**
