

Low-Power, Slew-Rate-Limited RS-485/RS-422 Transceivers

General Description

The ST485 is low-power transceivers for RS-485 and RS-422 communication. IC contains one driver and one receiver. The driver slew rates of the ST485 is not limited, allowing them to transmit up to 2.5Mbps.

These transceivers draw between 120µA and 500µA of supply current when unloaded or fully loaded with disabled drivers. All parts operate from a single 5V supply. Drivers are short-circuit current limited and are protected against excessive power dissipation by thermal shutdown circuitry that places the driver outputs into a high-impedance state. The receiver input has a fail-safe feature that guarantees a logic-high output if the input is open circuit. The ST485 is designed for half-duplex applications.

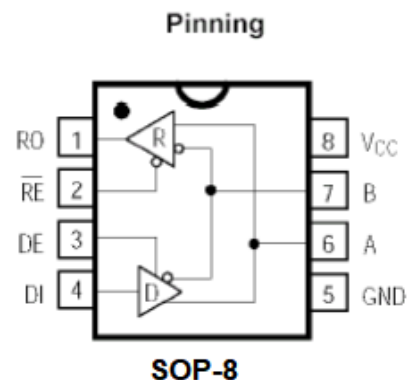

Features

- Low Quiescent Current: 300µA
- -7V to +12V Common-Mode Input Voltage Range
- Three-State Outputs
- 30ns Propagation Delays, 5ns Skew
- Full-Duplex and Half-Duplex Versions Available
- Operate from a Single 5V Supply
- Allows up to 32 Transceivers on the Bus
- Data rate: 2,5 Mbps
- Current-Limiting and Thermal Shutdown for Driver Overload Protection

Low-Power, Slew-Rate-Limited RS-485/RS-422 Transceivers
ABSOLUTE MAXIMUM RATINGS

Supply Voltage (V_{CC}) 12V	Continuous Power Dissipation ($T_A = +70^\circ\text{C}$)
Control Input Voltage -0.5V to ($V_{CC} + 0.5\text{V}$)	8-Pin Plastic DIP (derate 9.09mW/ $^\circ\text{C}$ above +70 $^\circ\text{C}$) 727mW
Driver Input Voltage (DI) -0.5V to ($V_{CC} + 0.5\text{V}$)	8-Pin SO (derate 5.88mW/ $^\circ\text{C}$ above +70 $^\circ\text{C}$) 471mW
Driver Output Voltage (A, B) -8V to +12.5V	Operating Temperature Ranges -40 $^\circ\text{C}$ to +105 $^\circ\text{C}$
Receiver Input Voltage (A, B) -8V to +12.5V	Storage Temperature Range -65 $^\circ\text{C}$ to +160 $^\circ\text{C}$
Receiver Output Voltage (RO) -0.5V to ($V_{CC} + 0.5\text{V}$)	Lead Temperature (soldering, 10sec) +300 $^\circ\text{C}$

DC ELECTRICAL CHARACTERISTICS

($V_{CC} = 5\text{V} \pm 5\%$, $T_A = T_{MIN}$ to T_{MAX} , unless otherwise noted.) (Notes 1, 2)

PARAMETER	SYMBOL	CONDITIONS	MIN	TYP	MAX	UNITS
Differential Driver Output (no load)	V_{OD1}				5	V
Differential Driver Output (with load)	V_{OD2}	R = 50 Ω (RS-422)	2			V
		R = 27 Ω (RS-485), Figure 4	1.5		5	
Change in Magnitude of Driver Differential Output Voltage for Complementary Output States	ΔV_{OD}	R = 27 Ω or 50 Ω , Figure 4			0.2	V
Driver Common-Mode Output Voltage	V_{OC}	R = 27 Ω or 50 Ω , Figure 4			3	V
Change in Magnitude of Driver Common-Mode Output Voltage for Complementary Output States	ΔV_{OD}	R = 27 Ω or 50 Ω , Figure 4			0.2	V
Input High Voltage	V_{IH}	DE, DI, $\overline{\text{RE}}$	2.0			V
Input Low Voltage	V_{IL}	DE, DI, $\overline{\text{RE}}$			0.8	V
Input Current	I_{IN1}	DE, DI, $\overline{\text{RE}}$			± 2	μA
Input Current (A, B)	I_{IN2}	DE = 0V; $V_{CC} = 0\text{V}$ or 5.25V,	$V_{IN} = 12\text{V}$		1.0	mA
			$V_{IN} = -7\text{V}$		-0.8	
Receiver Differential Threshold Voltage	V_{TH}	$-7\text{V} \leq V_{CM} \leq 12\text{V}$	-0.2		0.2	V
Receiver Input Hysteresis	ΔV_{TH}	$V_{CM} = 0\text{V}$		70		mV
Receiver Output High Voltage	V_{OH}	$I_o = -4\text{mA}$, VID = 200mV	3.5			V
Receiver Output Low Voltage	V_{OL}	$I_o = 4\text{mA}$, VID = -200mV			0.4	V
Three-State (high impedance) Output Current at Receiver	I_{OZR}	$0.4\text{V} \leq V_o \leq 2.4\text{V}$			± 1	μA
Receiver Input Resistance	R_{IN}	$-7\text{V} \leq V_{CM} \leq 12\text{V}$				k Ω

Low-Power, Slew-Rate-Limited RS-485/RS-422 Transceivers
DC ELECTRICAL CHARACTERISTICS (continued)

 (V_{CC} = 5V ±5%, T_A = T_{MIN} to T_{MAX}, unless otherwise noted.) (Notes 1, 2)

PARAMETER	SYMBOL	CONDITIONS	MIN	TYP	MAX	UNITS
No-Load Supply Current (Note 3)	I _{CC}	DE = V _{CC}		500	900	
		RE = 0V or V _{CC}		300	500	μA
		DE = 0V				
Driver Short-Circuit Current,						
	I _{OSD1}	-7V ≤ V _O ≤ 12V (Note 4)	35		250	mA
V _O = High						
Driver Short-Circuit Current,						
	I _{OSD2}	-7V ≤ V _O ≤ 12V (Note 4)	35		250	mA
V _O = Low						
Receiver Short-Circuit Current	I _{OSR}	0V ≤ V _O ≤ V _{CC}	7		95	mA

SWITCHING CHARACTERISTICS

 (V_{CC} = 5V ±5%, T_A = T_{MIN} to T_{MAX}, unless otherwise noted.) (Notes 1, 2)

PARAMETER	SYMBOL	CONDITIONS	MIN	TYP	MAX	UNITS
Driver Input to Output	t _{PLH}	R _{DIFF} = 54Ω	10	30	60	ns
	t _{PHL}	C _{L1} = C _{L2} = 100pF	10	30	60	
Driver Output Skew to Output	t _{SKEW}	R _{DIFF} = 54Ω, C _{L1} = C _{L2} = 100pF		5	10	ns
Driver Enable to Output High	t _{ZH}	C _L = 100pF, S2 closed		40	70	ns
Driver Enable to Output Low	t _{ZL}	C _L = 100pF, S1 closed		40	70	ns
Driver Disable Time from Low	t _{LZ}	C _L = 15pF, S1 closed		40	70	ns
Driver Disable Time from High	t _{HZ}	C _L = 15pF, S2 closed		40	70	ns
t _{PLH} - t _{PHL} Differential	t _{SKD}	R _{DIFF} = 54Ω		13		ns
Receiver Skew		C _{L1} = C _{L2} = 100pF				
Receiver Enable to Output Low	t _{ZL}	C _{RL} = 15pF, S1 closed		20	50	ns
Receiver Enable to Output High	t _{ZH}	C _{RL} = 15pF, S2 closed		20	50	ns
Receiver Disable Time from Low	t _{LZ}	C _{RL} = 15pF, S1 closed		20	50	ns
Receiver Disable Time from High	t _{HZ}	C _{RL} = 15pF, S2 closed		20	50	ns
Maximum Data Rate	f _{MAX}		2.5			Mbps

Low-Power, Slew-Rate-Limited RS-485/RS-422 Transceivers

Operation timing diagrams of ST485

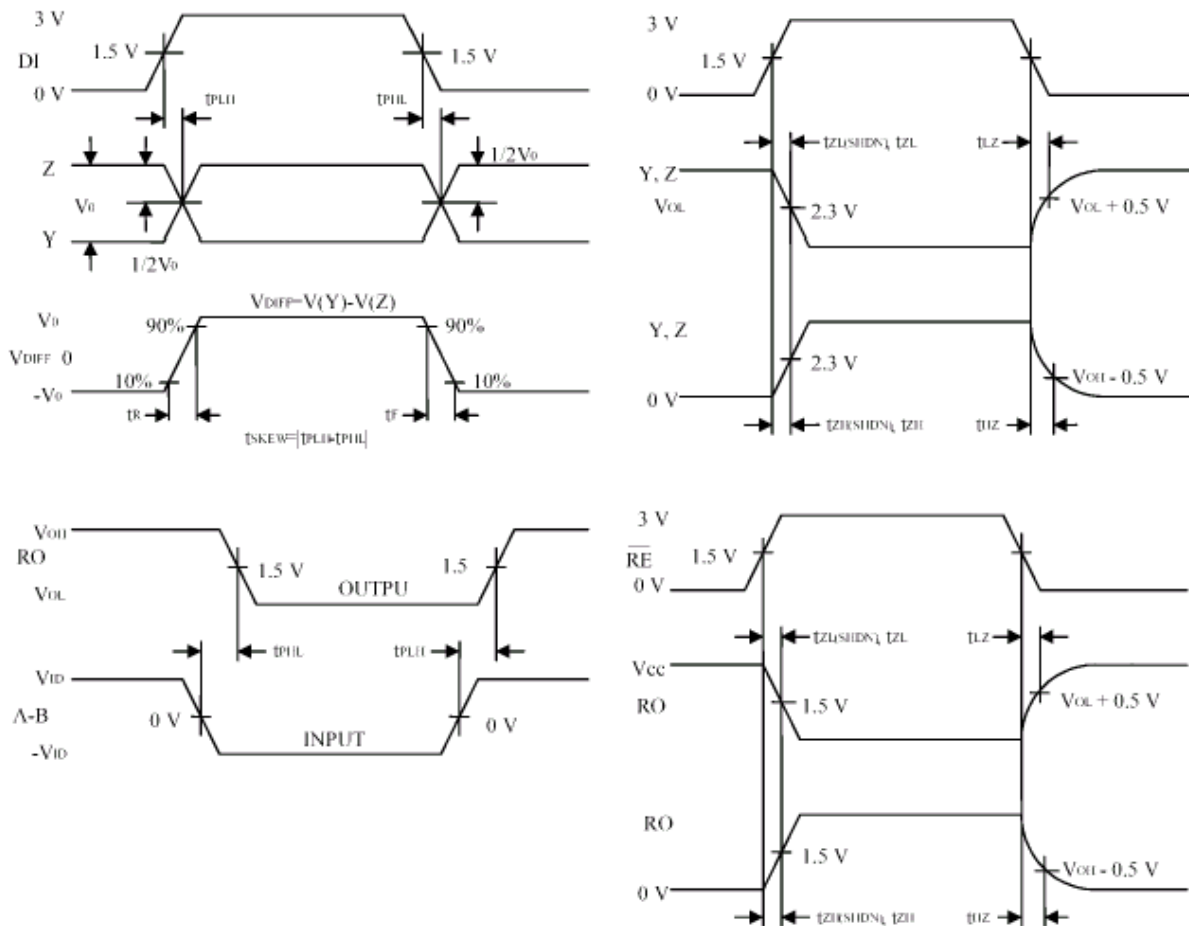
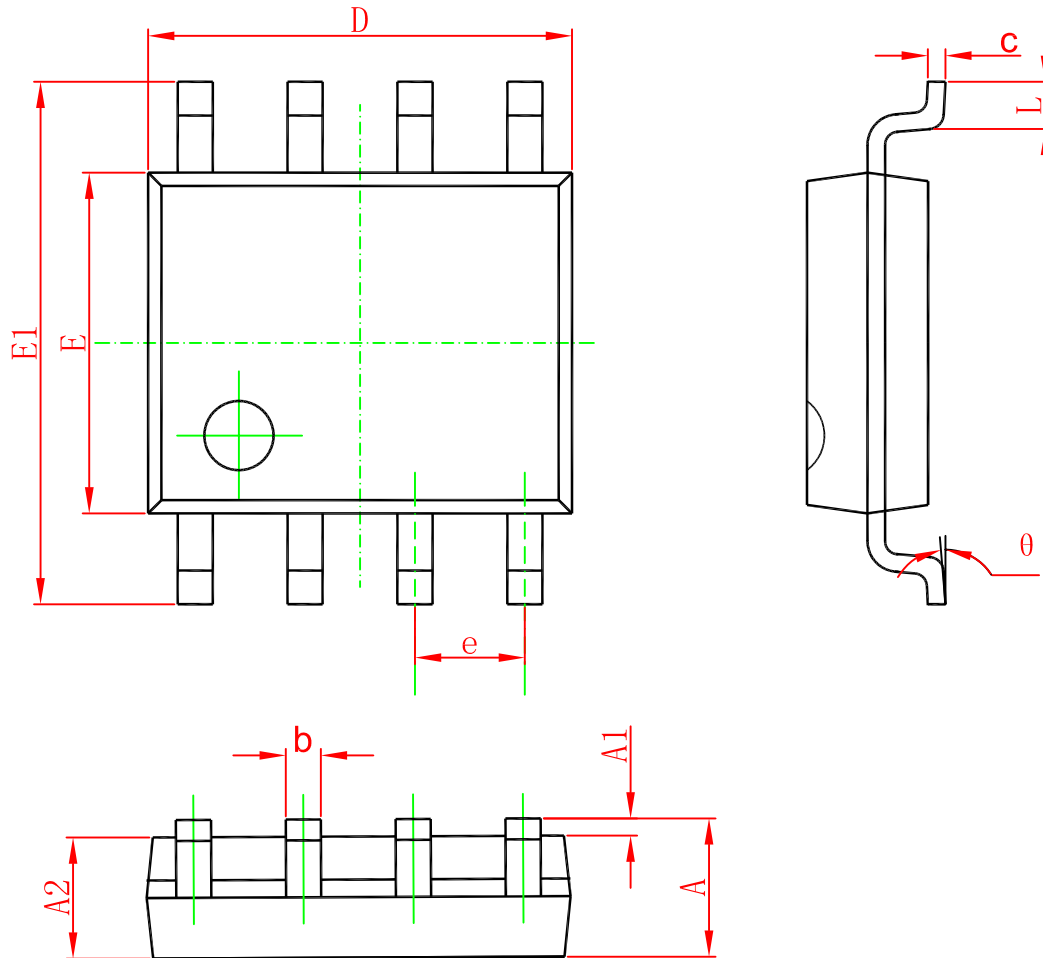

Table of ST485 operation

Transmission					Receipt			
Inputs			Outputs X		Inputs			Outputs
RE	DE	DI	Z	Y	RE	DE	A-B	RO
X	1	1	0	1	0	0	+0.2V	1
X	1	0	1	0	0	0	-0.2V	0
0	0	X	Z	Z	0	0	open	1
1	0	X	Z	Z	1	0	X	Z

X-don't care
Z-high resistance

SOP-8



Symbol	Dimensions In Millimeters		Dimensions In Inches	
	Min	Max	Min	Max
A	1.350	1.750	0.053	0.069
A1	0.100	0.250	0.004	0.010
A2	1.350	1.550	0.053	0.061
b	0.330	0.510	0.013	0.020
c	0.170	0.250	0.006	0.010
D	4.700	5.100	0.185	0.200
E	3.800	4.000	0.150	0.157
E1	5.800	6.200	0.228	0.244
e	1.270(BSC)		0.050(BSC)	
L	0.400	1.270	0.016	0.050
θ	0°	8°	0°	8°

Ordering information

Order code	Package	Baseqty	Deliverymode
UMW ST485EBDR	SOP-8	2500	Tape and reel