

1. Features

- n Advanced Planar Process
- n $R_{DS(ON)}=0.75\Omega(\text{typ.})@V_{GS}=10V$
- n Low Gate Charge Minimize Switching Loss
- n Rugged Polysilicon Gate Structure

2. Applications

- n BLDC Motor Driver
- n Electric Welder
- n High Efficiency SMPS

3. Symbol

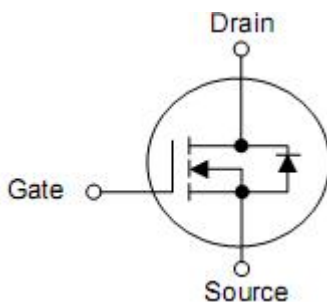
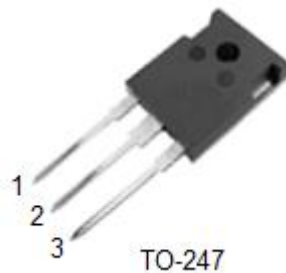

Pin	Function
1	Gate
2	Drain
3	Source

4. Ordering Information

Part Number	Package	Brand
KNM6390A	TO-247	KIA

5. Absolute maximum ratings

$T_C=25^{\circ}\text{C}$ unless otherwise noted

Parameter	Symbol	Rating	Units
Drain-source voltage	V_{DSS}	900	V
Gate-to-Source Voltage	V_{GSS}	± 30	V
Continuous drain current	$T_C=25^{\circ}\text{C}$	I_D	12
	$T_C=100^{\circ}\text{C}$	I_D	7.5
Pulsed Drain Current at $V_{GS}=10\text{V}$ ^{2,4)}	I_{DM}	48	A
Single pulse avalanche energy	E_{AS}	1200	mJ
Peak Diode Recovery dv/dt ³⁾	dv/dt	5.0	V/ns
Power dissipation	P_D	175	W
Derate above 25°C		1.4	W/ $^{\circ}\text{C}$
Maximum Temperature for Soldering Leads at 0.063in (1.6mm) from Case for 10 seconds, Package Body for 10 seconds	T_L T_{PAK}	300 260	$^{\circ}\text{C}$
Operating junction and storage temperature range	T_J, T_{STG}	-55 to 150	$^{\circ}\text{C}$

Caution: Stresses greater than those listed in the “Absolute Maximum Ratings” may cause permanent damage to the device.

6. Thermal characteristics

Parameter	Symbol	Rating	Unit
Thermal resistance junction-case	$R_{\theta JC}$	0.714	$^{\circ}\text{C}/\text{W}$
Thermal Resistance, Junction-to-Ambient	$R_{\theta JA}$	55	$^{\circ}\text{C}/\text{W}$

7. Electrical characteristics

(T_J=25°C unless otherwise noted)

Parameter	Symbol	Test Conditions	Min	Typ	Max	Units
Drain-source breakdown voltage	BV _{DSS}	V _{GS} =0V, I _D =250uA	900	-	-	V
Drain-source leakage current	I _{DSS}	V _{DS} =900V, V _{GS} =0V	-	-	1	uA
		V _{DS} =720V, T _C =125°C			125	
Gate-source forward leakage	I _{GSS}	V _{GS} =±30V, V _{DS} =0V	-	-	±100	nA
Drain-source on-resistance	R _{DS(on)}	V _{GS} =10V, I _D =6A	-	0.75	1.0	Ω
Gate threshold voltage	V _{GS(TH)}	V _{DS} =V _{GS} , I _D =250uA	2.0	-	4.0	V
Forward Transconductance	g _{fs}	V _{DS} =25V, I _D =6A	-	32	-	S
Input capacitance	C _{iss}	V _{DS} =25V, V _{GS} =0V f=1MHz	-	3002	-	pF
Reverse transfer capacitance	C _{rss}		-	75	-	pF
Output capacitance	C _{oss}		-	248	-	pF
Total gate charge	Q _g	V _{DD} =450V, I _D =12A V _{GS} =0~10V	-	84	-	nC
Gate-source charge	Q _{gs}		-	17	-	nC
Gate-drain charge	Q _{gd}		-	33	-	nC
Turn-on delay time	t _{d(on)}	V _{DD} =450V, V _{GS} =10V, R _G =10Ω, I _D =12A		26		ns
Rise time	t _r			80		ns
Turn-off delay time	t _{d(off)}			66		ns
Fall time	t _f			78		ns
Continuous Source Current ²⁾	I _{SD}	Integral PN-diode in MOSFET			12	A
Pulsed Source Current ²⁾	I _{SM}		-	-	48	
Diode forward voltage	V _{SD}	I _S =12A, V _{GS} =0V,	-	-	1.5	V
Reverse Recovery Time	t _{rr}	V _{GS} =0V, I _F =12A, dI _F /dt=100A/μs ⁴⁾	-	550	-	nS
Reverse Recovery Charge	Q _{rr}		-	4.5	-	nC

Note:

- 1) T_J=+25 °C to +150 °C
- 2) Silicon limited current only.
- 3) Package limited current.
- 4) Repetitive rating; pulse width limited by maximum junction temperature.
- 5) Pulse width ≤ 380us; duty cycle ≤ 2%.

8. Typical operating characteristics

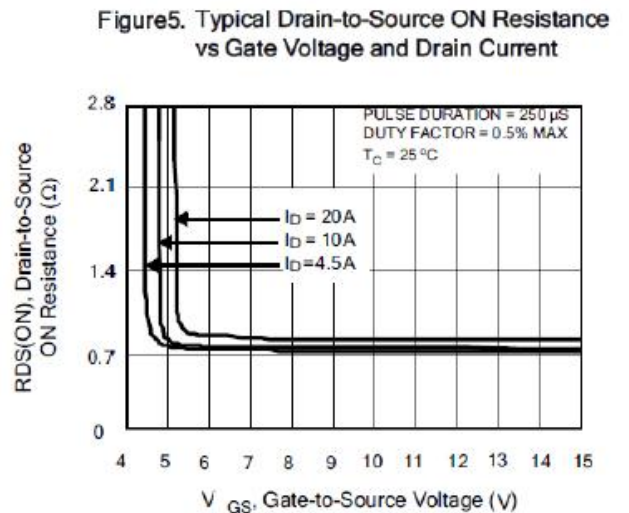
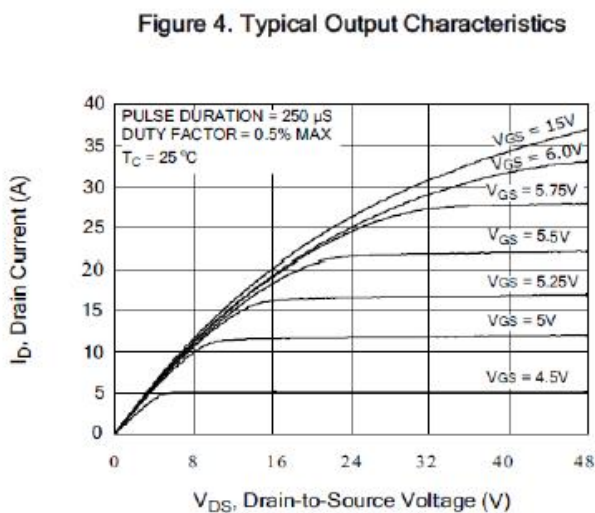
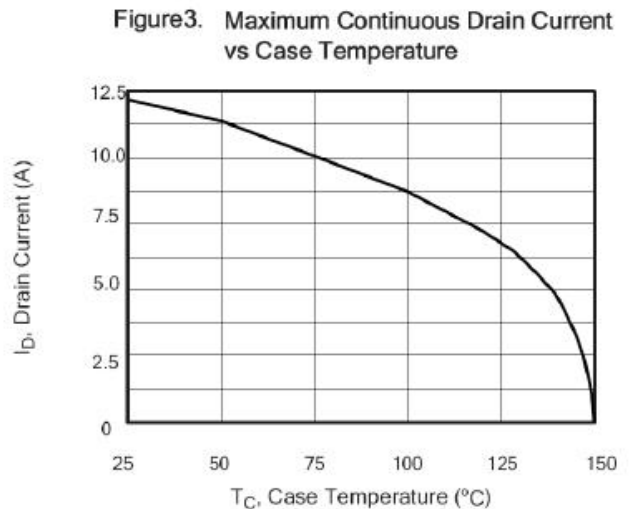
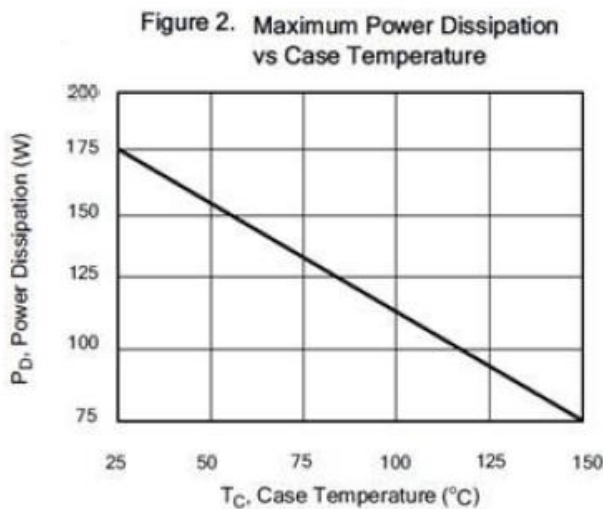
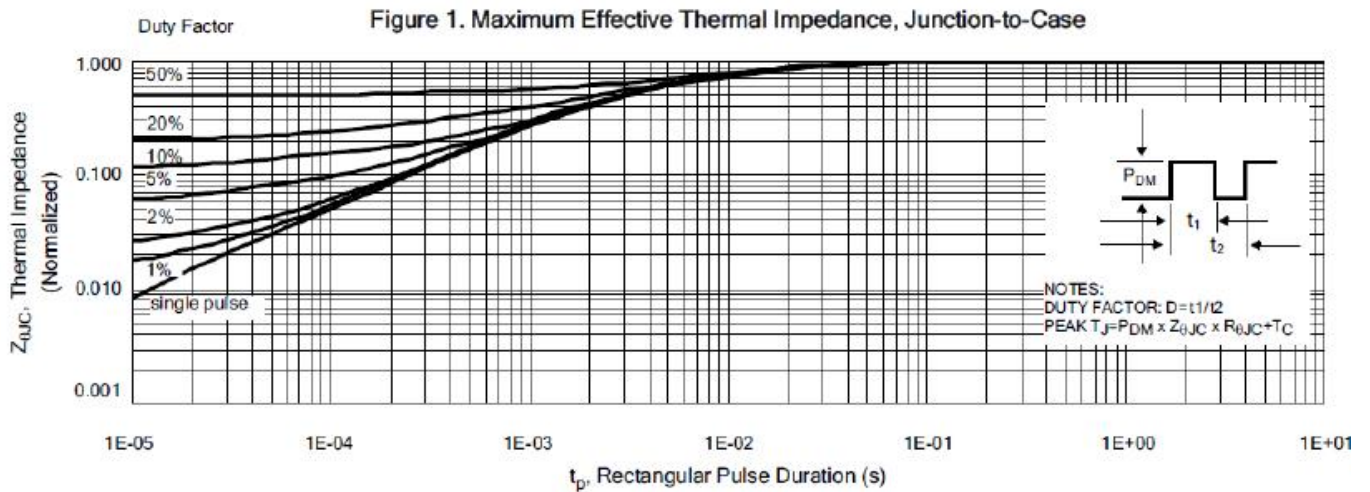

Figure 6. Maximum Peak Current Capability

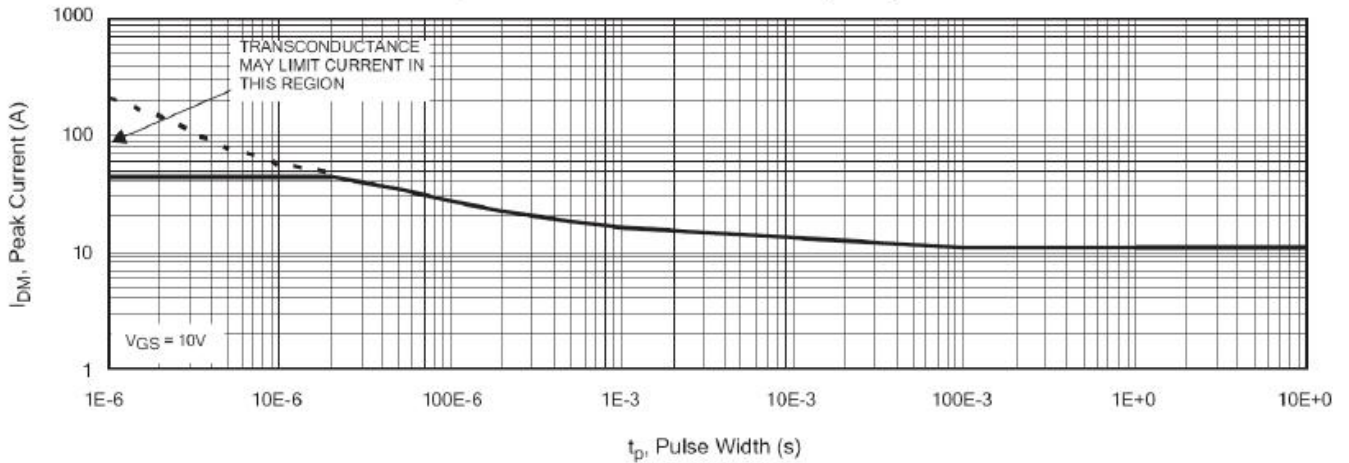

Figure 7. Typical Transfer Characteristics

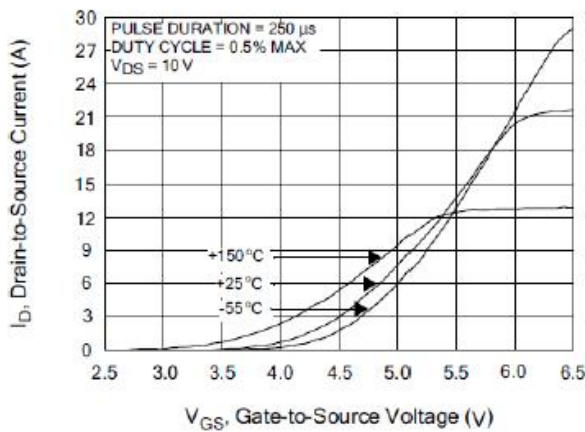

Figure 8. Unclamped Inductive Switching Capability

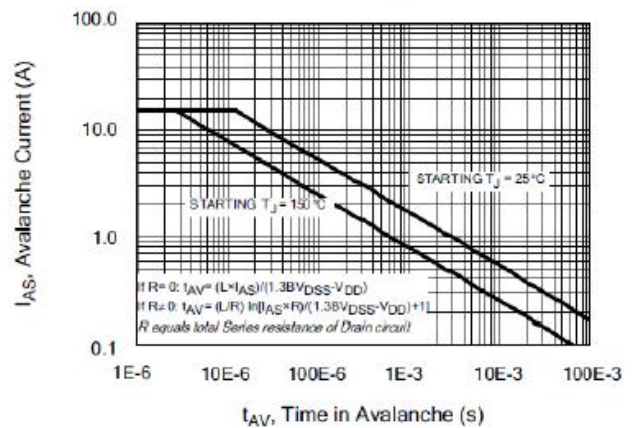

Figure 9. Typical Drain-to-Source ON Resistance vs Drain Current

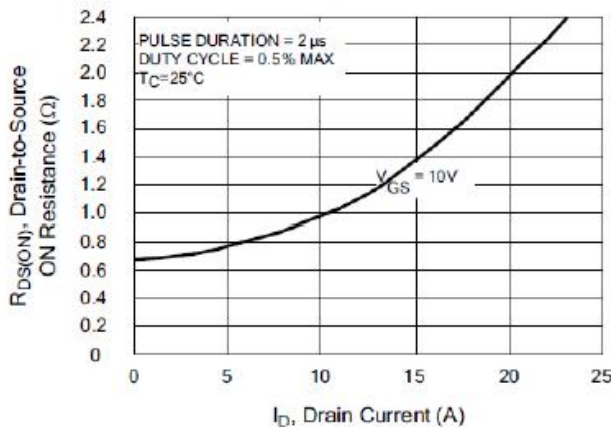

Figure 10. Typical Drain-to-Source ON Resistance vs Junction Temperature

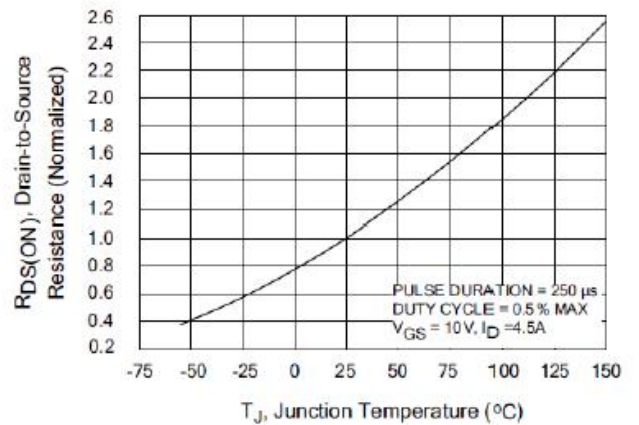

Figure 11. Typical Breakdown Voltage vs Junction Temperature

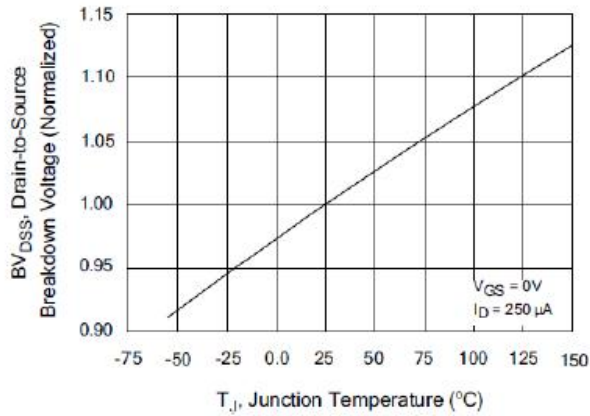

Figure 12. Typical Threshold Voltage vs Junction Temperature

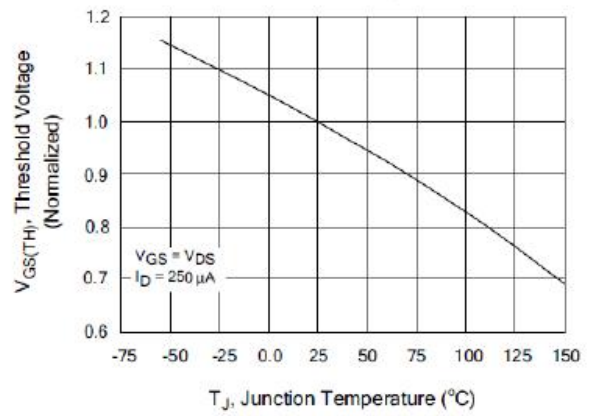

Figure 13. Maximum Forward Bias Safe Operating Area

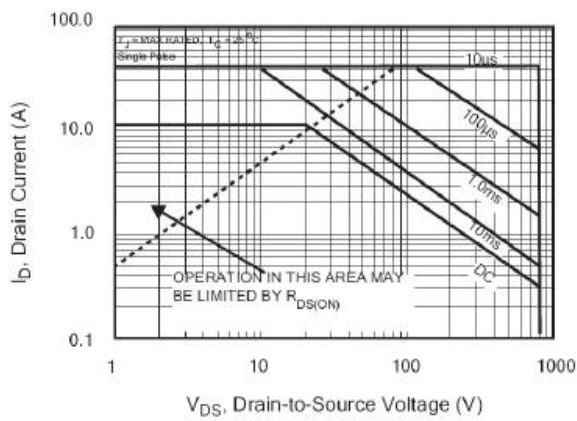
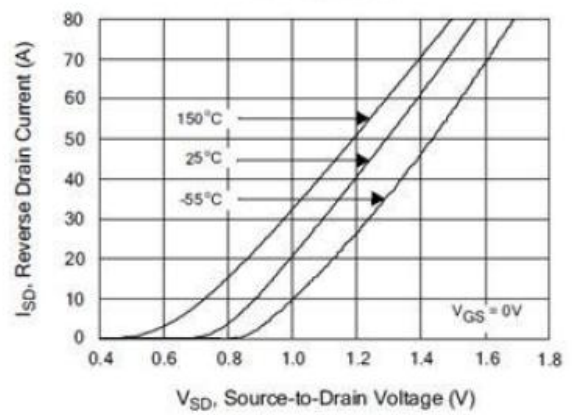

Figure 14. Typical Body Diode Transfer Characteristics



9. Test Circuits and Waveforms

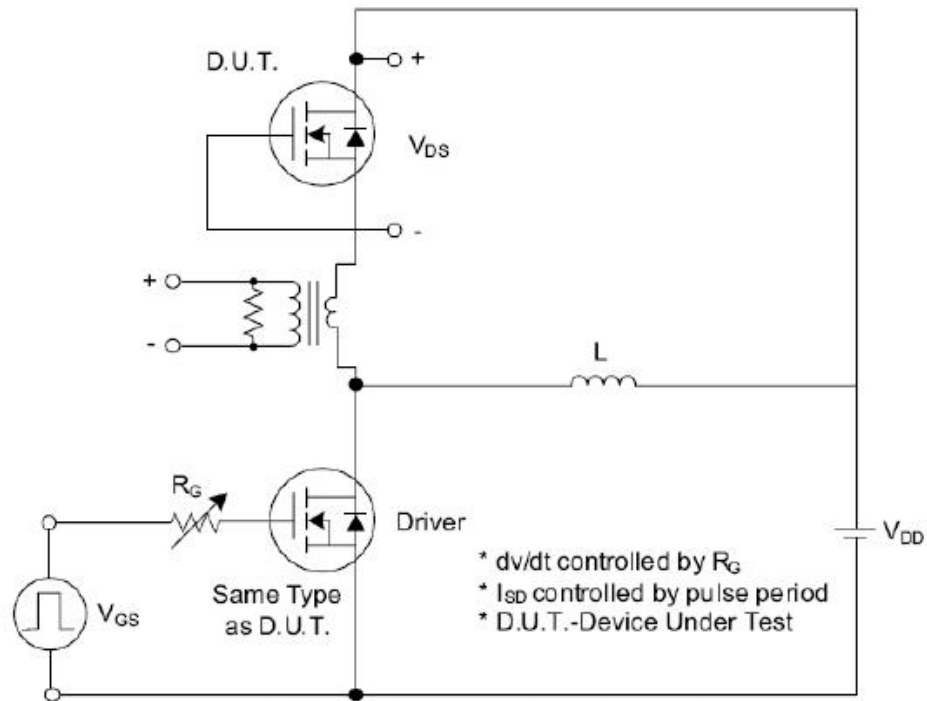

Fig. 1.1 Peak Diode Recovery dv/dt Test Circuit

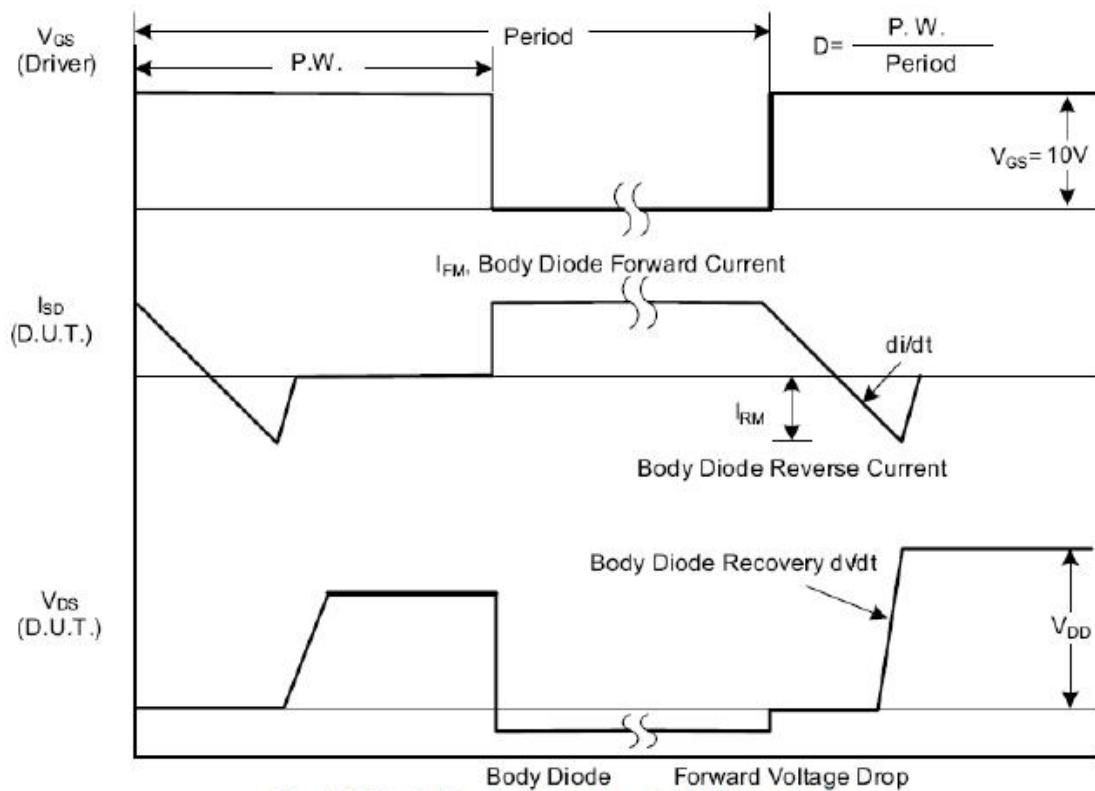

Fig. 1.2 Peak Diode Recovery dv/dt Waveforms

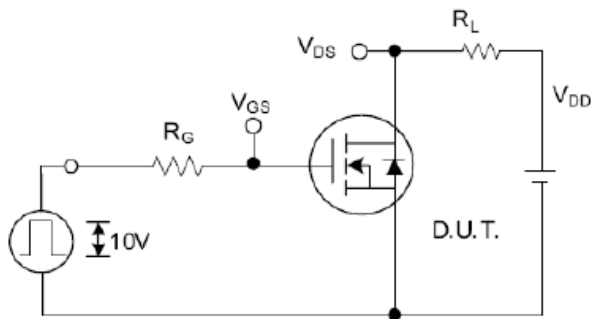

Fig. 2.1 Switching Test Circuit

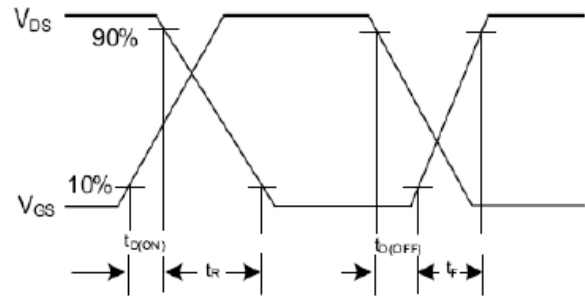

Fig. 2.2 Switching Waveforms

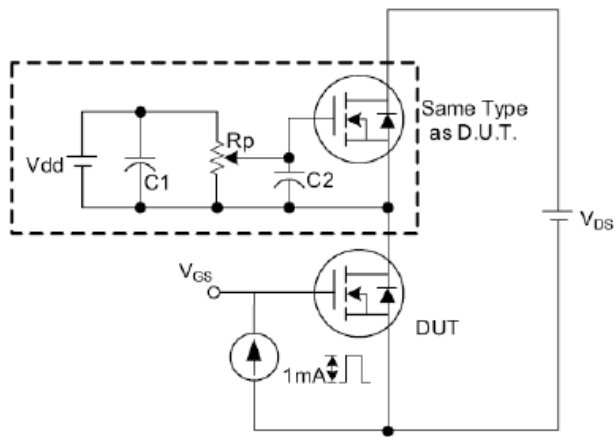

Fig. 3.1 Gate Charge Test Circuit

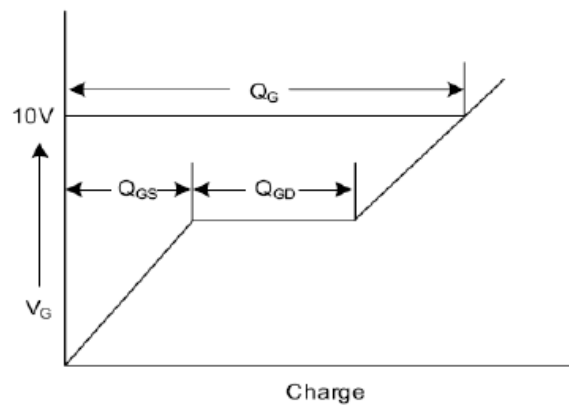

Fig. 3.2 Gate Charge Waveform

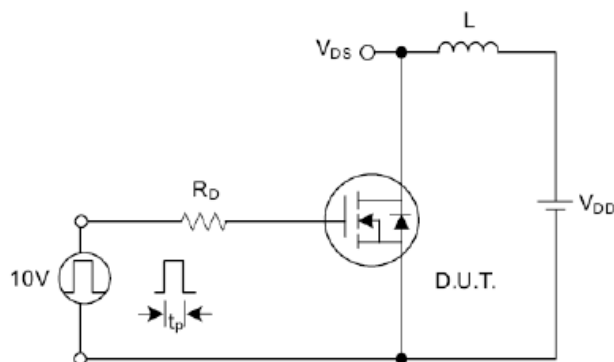

Fig. 4.1 Unclamped Inductive Switching Test Circuit

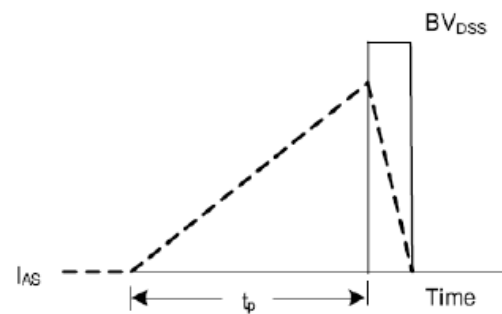

Fig. 4.2 Unclamped Inductive Switching Waveforms