

4A Single-Channel, Low-Side, Non-Inverting Gate Driver

Description

The UMW UCC27517ADBVR device is a low voltage power MOSFET and IGBT in phase gate driver. Proprietary latch-immune of CMOS technology enables single-chip integrated architectures with high robustness. The UMW UCC27517ADBVR logic input level is compatible with CMOS or TTL logic output levels down to 3.3V. The output driver has Internal Undervoltage Lockout (UVLO) circuitry with hysteresis and buffer stage of output current. The UCC27517ADBVR is designed to operate over a wide VCC range of 5 V to 25 V and wide temperature range of -40°C to 125°C.

Applications

- Switch-Mode Power Supplies
- General Gate Driver
- Driving MOSFETs and IGBTs

Features

- Dual Input Design (Choice of an Inverting (IN- pin) or Non-inverting (IN+ pin) Driver Configuration)
 - Unused Input Pin Can Be Used for Enable or Disable Function
- TTL and CMOS Compatible Input-Logic Threshold
- 5 to 25-V Single-Supply Range
- Operating Temperature Range of -40 to 125°C
- Undervoltage Lockout
 - Undervoltage Lockout turn-on threshold 4.0V
 - Undervoltage Lockout turn-off threshold 3.9V
- Turn on/Turn off Delays:
 - Ton/Toff =30ns/30ns
- 4-A Peak Source and Sink-Drive Current

Pin Configuration

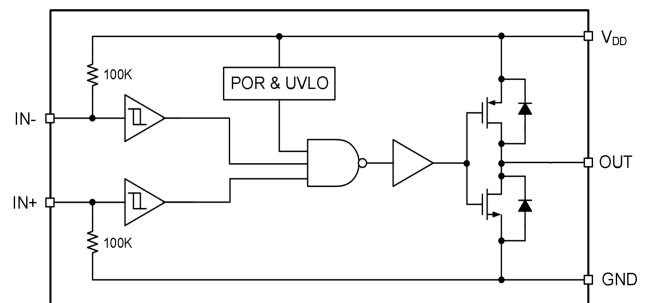

4A Single-Channel, Low-Side, Non-Inverting Gate Driver

Pin Configuration and Functions

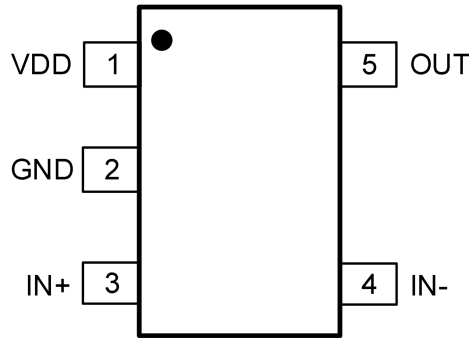

5-Pin SOT23-5 Package Top View

Pin Functions

PIN	NAME	DESCRIPTION
1	VDD	Bias supply input
2	GND	Ground: All signals are referenced to this pin.
3	IN+	Non-inverting Input: When the driver is used in inverting configuration, connect IN+ to VDD in order to enable output, OUT held LOW if IN+ is unbiased or floating.
4	IN-	Inverting Input: When the driver is used in non-inverting configuration, connect IN- to GND in order to enable output, OUT held LOW if IN- is unbiased or floating.
5	OUT	Sourcing/Sinking Current Output of Driver

4A Single-Channel, Low-Side, Non-Inverting Gate Driver

Absolute Maximum Ratings

Stresses beyond those listed under Absolute Maximum Ratings may cause permanent damage to the device. All voltages are with respect to GND unless otherwise noted, Currents are positive into, negative out of the specified terminal, environment temperature is 25 °C.

Symbol	Definition	MIN	MAX	UNIT
V _{CC}	Supply voltage range	-0.3	25	V
V _O	OUT voltage range	-0.3	V _{CC} +0.3	
V _{IN}	IN+, IN- voltage	-0.3	V _{CC} +0.3	
R _{thJA}	thermal resistance	—	151	°C/W
T _S	Storage temperature	-55	+150	°C
T _J	Operating junction temperature	—	+150	
T _L	Lead temperature	—	300	
V _{CC}	Supply voltage range	5.0	20	V
V _O	OUT voltage range	0	V _{CC}	
V _{IN}	IN+, IN- voltage	0	V _{CC}	
T _A	ambient temperature	-40	125	°C

4A Single-Channel, Low-Side, Non-Inverting Gate Driver

Electrical Characteristics

TA= 25°C, VCC=15V, CL=1nF(unless otherwise noted)

Symbol	Definition	MIN	TYP	MAX	UNIT
V _{IH}	Input signal high threshold	2.7	—	—	V
V _{IL}	Input signal low threshold	—	—	0.8	V
V _{CCUV+}	Undervoltage Lockout (UVLO) turn-on threshold VCC	—	4.0	—	V
V _{CCUV-}	Undervoltage Lockout (UVLO) turn-off threshold VCC	—	3.9	—	V
V _{CCUVHY}	UVLO threshold hysteresis VCC	—	0.1	—	V
I _{IN+}	Input current(IN+/IN-=HIGH)	—	50	100	μA
I _{IN-}	Input current(IN+/IN-= LOW)	—	—	5	μA
V _{OH}	High output voltage	—	—	0.35	V
V _{OL}	Low output voltage	—	—	0.35	V
I _Q	VCC quiescent supply current	—	180	400	μA
I _{o+}	Output high short-circuit pulse current	—	4	—	A
I _{o-}	Output low short-circuit pulse current	—	4	—	A
t _R	Rise time	—	10	15	ns
t _F	Fall time	—	10	15	ns
t _{ON}	Turn-on propagation delay	—	30	60	ns
t _{OFF}	Turn-off propagation delay	—	30	60	ns

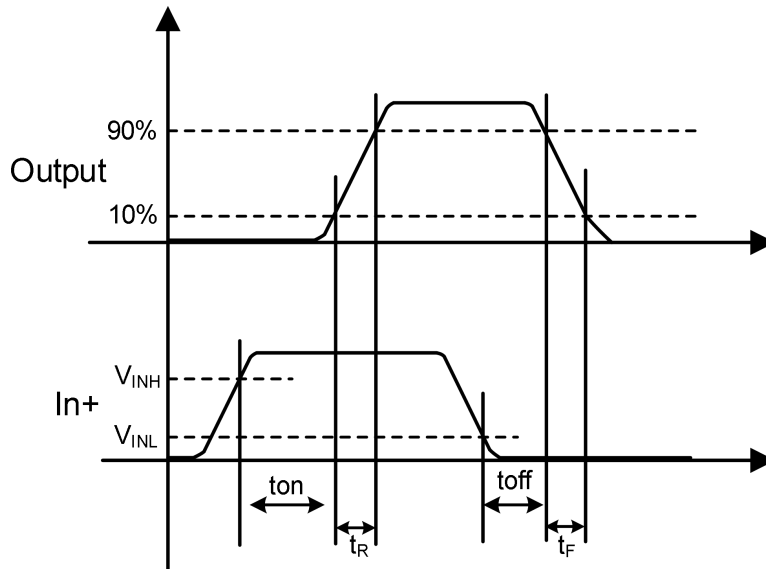

Figure 1 Input-Output waveform(non-inverting)

4A Single-Channel, Low-Side, Non-Inverting Gate Driver

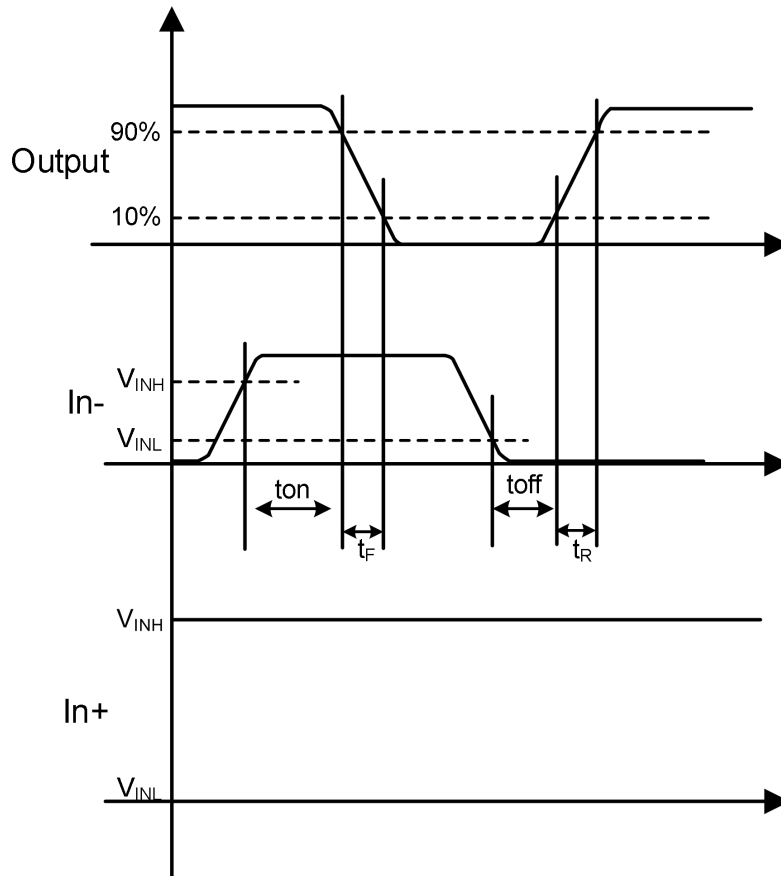

Figure 2 Input-Output waveform(inverting)

4A Single-Channel, Low-Side, Non-Inverting Gate Driver

Typical Characteristics

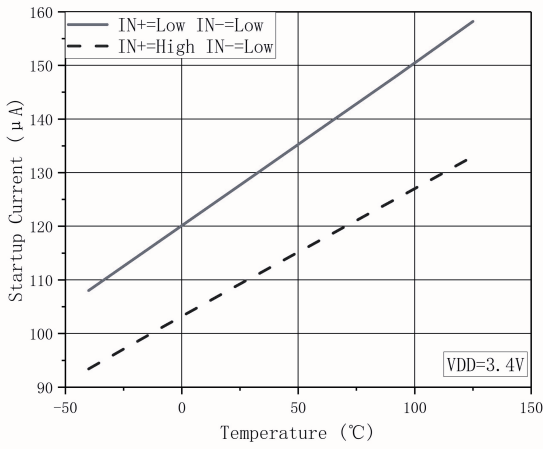

Figure 3. Start-Up Current vs Temperature

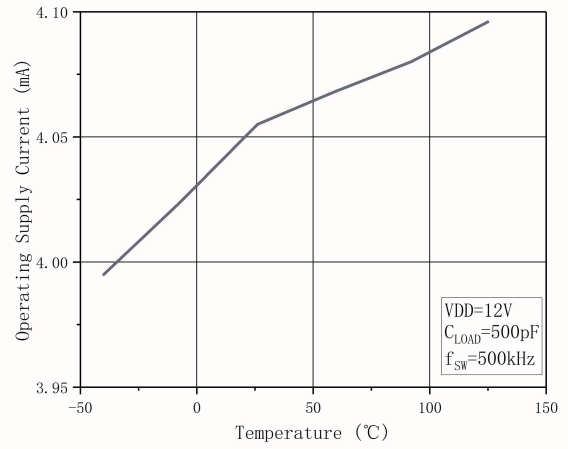

Figure 4. Operating Supply Current vs Temperature (Outputs Switching)

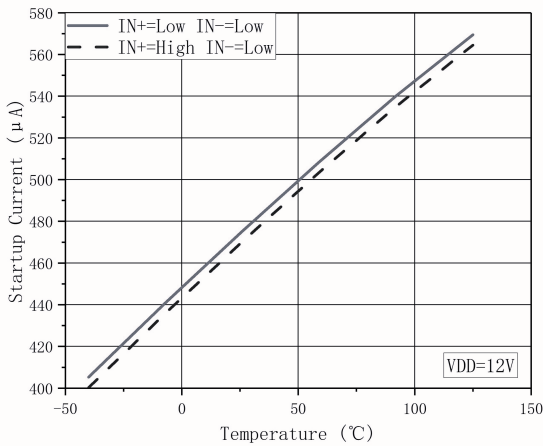

Figure 5. Supply Current vs Temperature (Outputs In DC On/Off Condition)

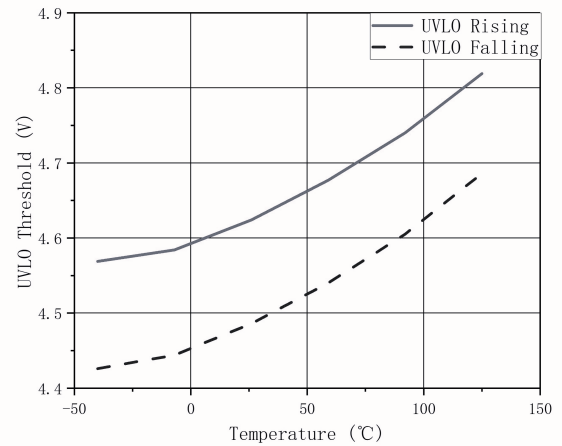

Figure 6. UVLO Threshold vs Temperature

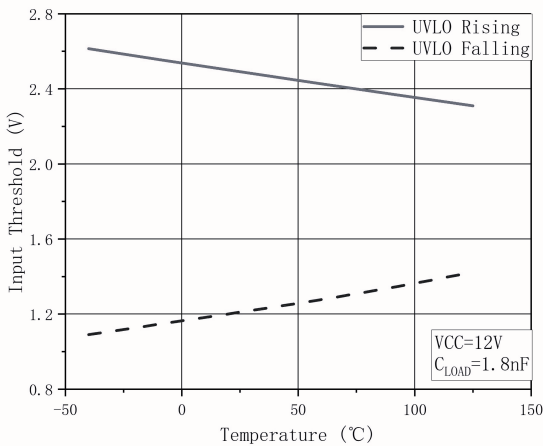

Figure 7. Input Threshold vs Temperature

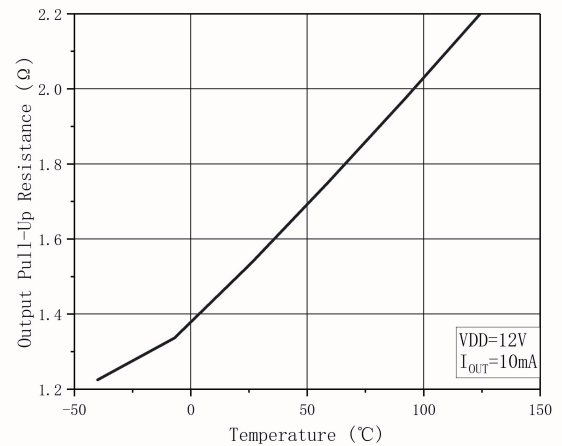

Figure 8. Output Pull-up Resistance vs Temperature

Typical Characteristics(continued)

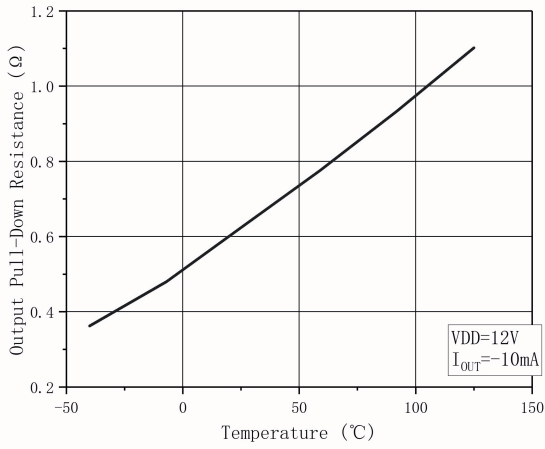

Figure 9. Output Pull-down Resistance vs Temperature

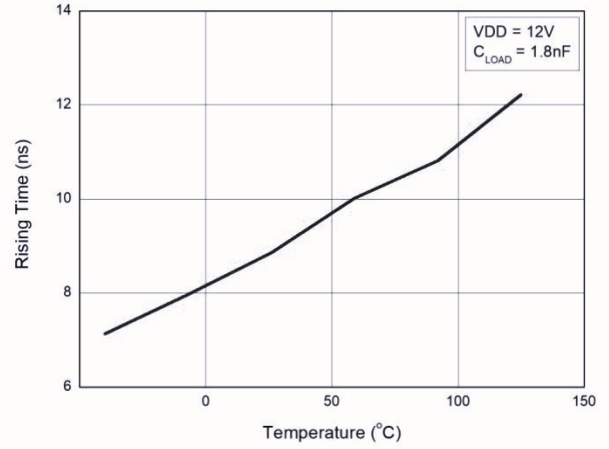

Figure 10. Rise Time vs Temperature

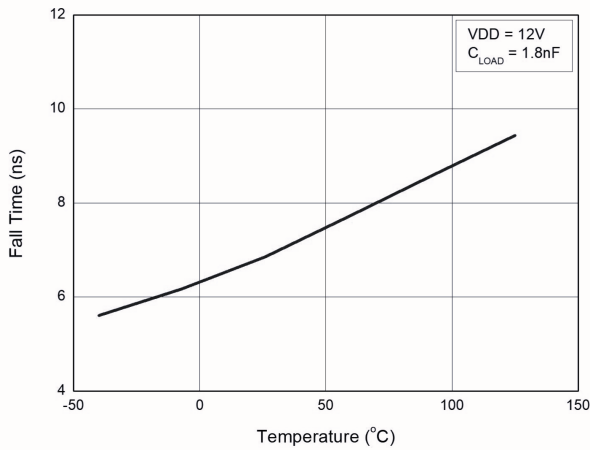

Figure 11. Fall Time vs Temperature

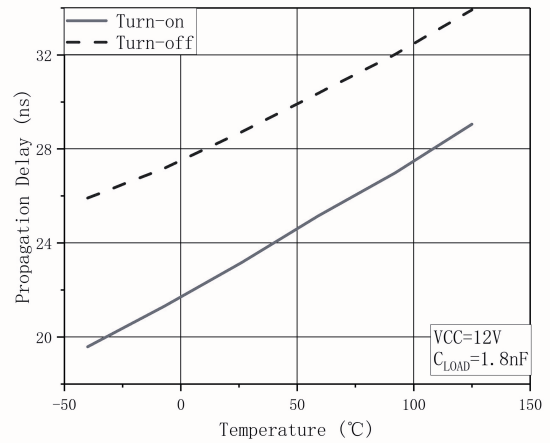

Figure 12. Input to Output Propagation Delay vs Temperature

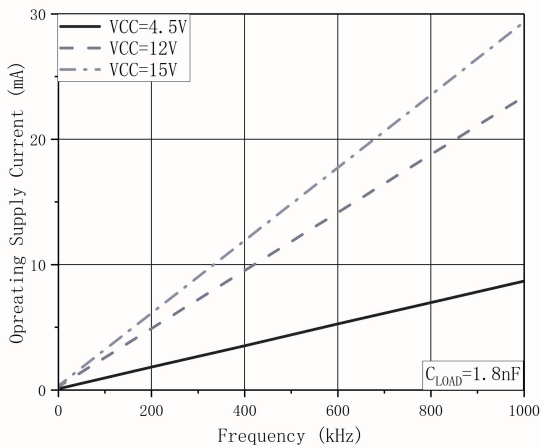

Figure 13. Operating Supply Current vs Frequency

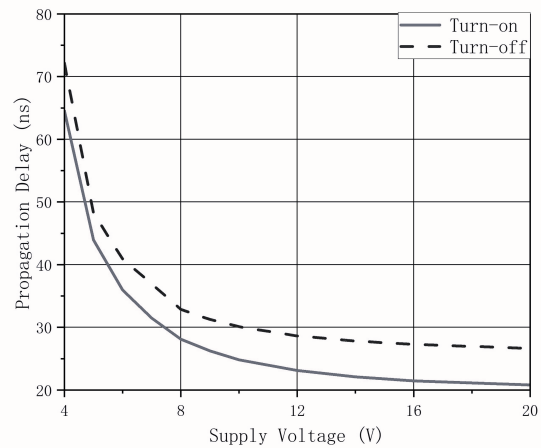

Figure 14. Propagation Delays vs Supply Voltage

Typical Characteristics(continued)

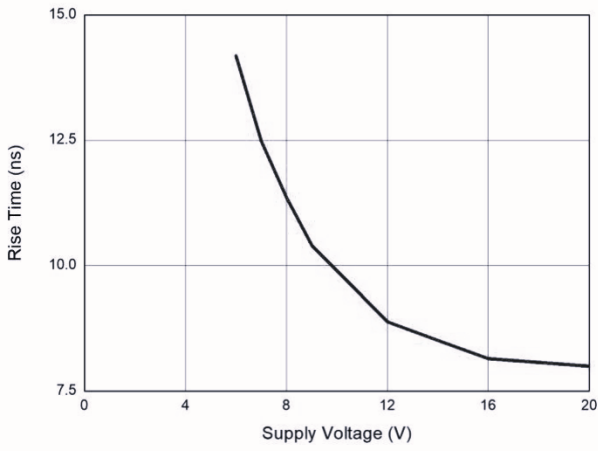

Figure 15. Rise Time vs Supply Voltage

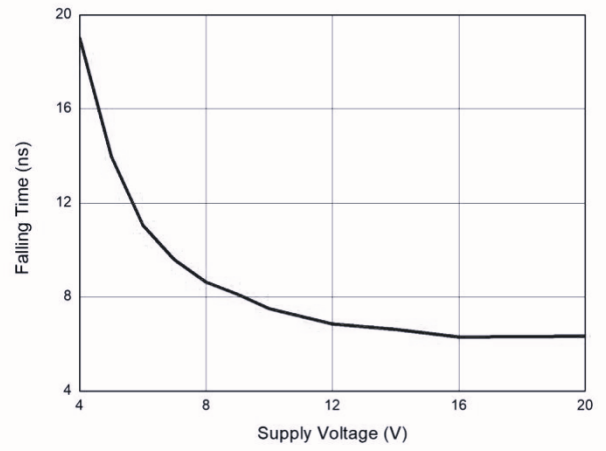
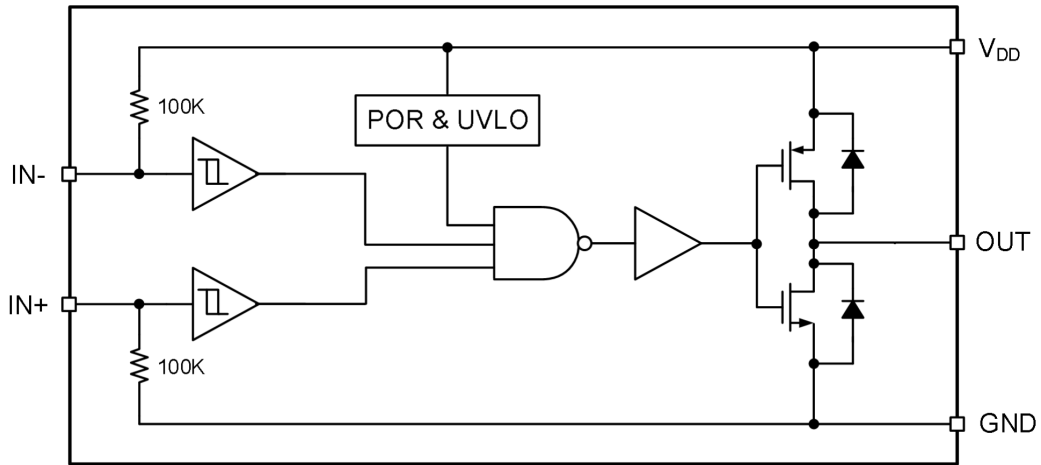

Figure 16. Fall Time vs Supply Voltage

4A Single-Channel, Low-Side, Non-Inverting Gate Driver

Functional Block Diagram



Device Functional Modes

Table 1 Device Logic Table

IN+	IN-	OUT
L	L	L
L	H	L
H	L	H
H	H	L
L	L	L
x ⁽¹⁾	Any	L
Any	x ⁽¹⁾	L

(1) Floating condition.

Typical Application

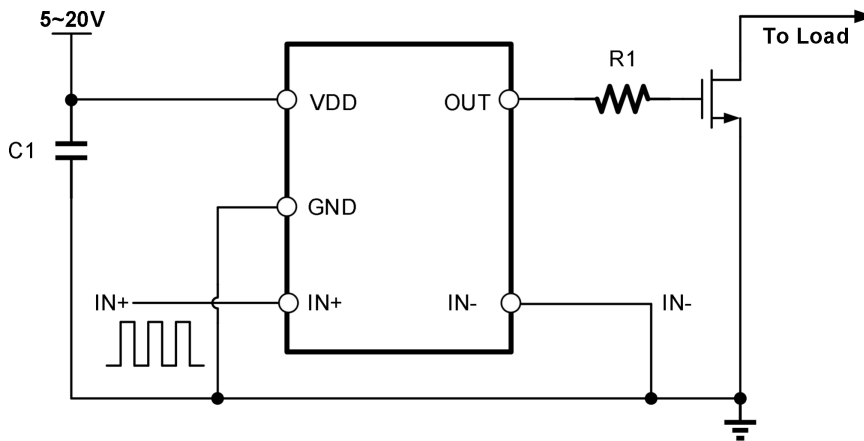

Figure 17 Non-inverting Typical Application Diagram of UCC27517ADBVR

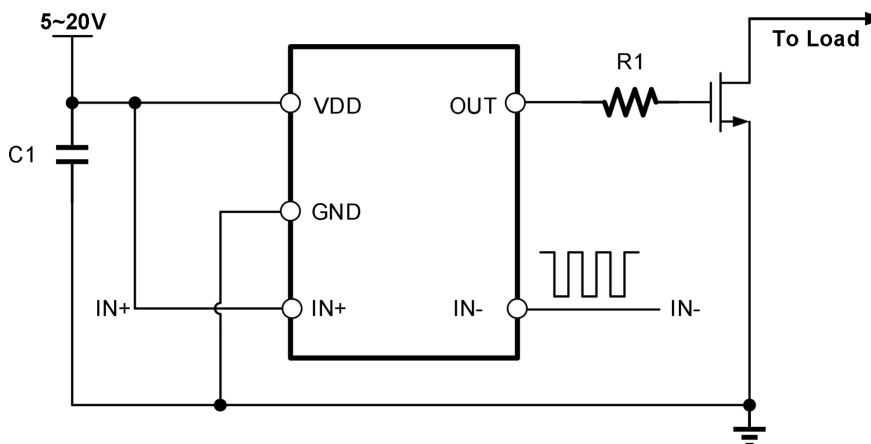
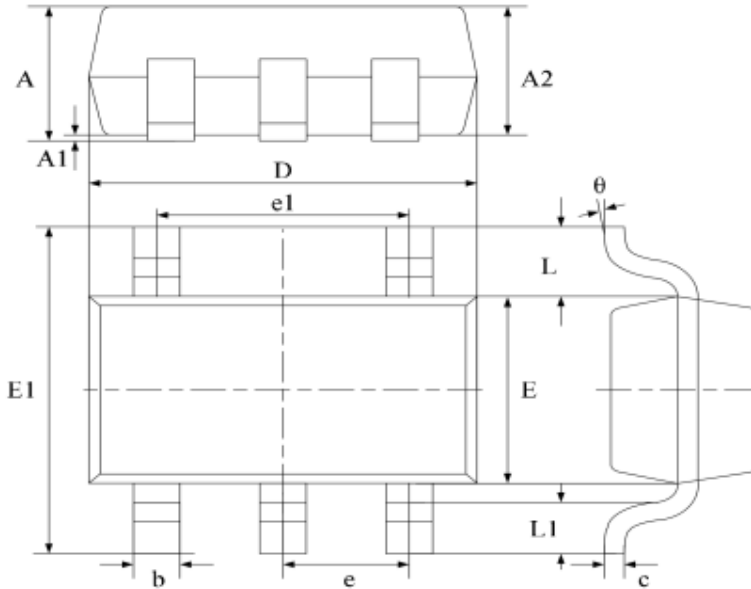

Figure 18 Inverting Typical Application Diagram of UCC27517ADBVR

SOT23-5



Symbol	Dimensions In Millimeters		Dimensions In Inches	
	Min	Max	Min	Max
A	1.040	1.350	0.042	0.055
A1	0.040	0.150	0.002	0.006
A2	1.000	1.200	0.041	0.049
b	0.380	0.480	0.015	0.020
c	0.110	0.210	0.004	0.009
D	2.720	3.120	0.111	0.127
E	1.400	1.800	0.057	0.073
E1	2.600	3.000	0.106	0.122
e	0.950 typ.		0.037 typ.	
e1	1.900 typ.		0.078 typ.	
L	0.700 ref.		0.028 ref.	
L1	0.300	0.600	0.012	0.024
theta	0°	8°	0°	8°

Marking

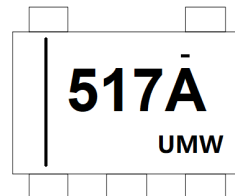

Ordering information

Order code	Package	Baseqty	Deliverymode
UMW UCC27517ADBVR	SOT23-5	3000	Tape and reel