

# 产品规格书

## PRODOCUT SPECIFICATION

客户名称

**CUSTOMER :** \_\_\_\_\_

产品名称

柔性端头多层片式陶瓷电容器

**PART NAME:** \_\_\_\_\_ **MLCC with Flexiterm** \_\_\_\_\_

规格

**SPECIFICATION:** \_\_\_\_\_ **0402~2225TYPE** \_\_\_\_\_

版本

**VERSION:** \_\_\_\_\_

日期

**DATE OF ISSUE:** \_\_\_\_\_

制 造 MANUFACTURER			客 户 CUSTOMER		
拟制 DESIGN	审核 CHECK	批准 APPROVAL	检验 INSPECTOR	审核 CHECK	批准 APPROVAL



序号 No	目 录 TABLE OF CONTENTS
1	应用范围      Application
2	型号表示法    Ordering Code
3	产品结构      Product Structure
4	容量范围及其电压    Capacitance Range and Operating Voltage
5	可靠性测试方法    Reliability Test Methods
6	包装    Package
7	储存方法      Storage Methods
8	使用前的注意事项    Precautions Before Use

■ **通用型系列片式陶瓷电容器**  
**General series of ceramic chip capacitors**

◆ **特征**  
**Feature**

- \* 叠层独石结构，具有高可靠性  
There is high reliability on monolithic structure of laminated layers.
- \* 具有优良的焊接与耐焊性能，适用于回流焊接与波峰焊接  
And its character of excellent soldering ability and soldering resistance ability is suitable for reflow soldering and peak soldering.
- \* 具有较高的容量且容量性能稳定  
It includes high and stable capacitance.
- \* 具有高强度的抗弯曲性能，下弯可达到 3mm  
High mechanical performance able to withstand, 3mm bend test.
- \* 采用柔性端头体系。  
Flexible termination system.
- \* 可减少线路板因弯曲导致的失效故障。  
Reduction in circuit board flex failures.

执行标准：GB/T 21041-2007 GB/T 21042-2007  
Executive Standard: GB/T 21041-2007 GB/T 21042-2007

◆ **应用**  
**Application**

- \* 应用于高弯曲的线路板。  
High Flexure Stress Circuit Boards.
- \* 应用于温度变化的线路。  
Variable Temperature Applications.

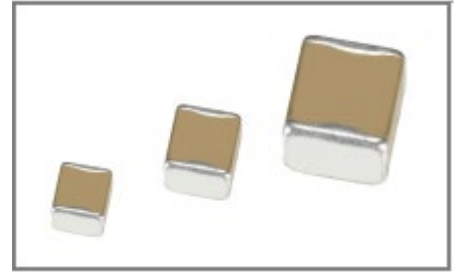

**◆型号表示法**  
**How To Order**

0805	B	102	k	500	A	T
<b>尺寸规格</b> Size Code			<b>标称容量</b> Nominal Capacitance		<b>额定电压</b> Rated Voltage 单位(unit): V	
尺寸规格 Size Code	长×宽 (L×W) inch	长×宽 (L×W) mm	表示方式 Express Method	实际值 Actual Value	表示方式 Express Method	实际值 Actual Value
0402	0.04×0.02	1.00×0.50	0R5	0.5	6R3	6.3
0603	0.06×0.03	1.60×0.80	1R0	1.0	500	50×10 <sup>0</sup>
0805	0.08×0.05	2.00×1.25	102	10×10 <sup>2</sup>	201	20×10 <sup>1</sup>
1206	0.12×0.06	3.20×1.60	注：头两位数字为有效数字，第三位数字为0的个数；R为小数点。 Note: the first two digits are significant; third digit denotes number of zeros; R=decimal point.		注：头两位数字为有效数字，第三位数字为0的个数；R为小数点。 Note: the first two digits are significant; third digit denotes number of zeros; R=decimal point.	
1210	0.12×0.10	3.20×2.50				
1808	0.18×0.08	4.50×2.00				
1812	0.18×0.12	4.50×3.20				
2211	0.22×0.11	5.70×0.28				
2220	0.22×0.20	5.70×5.00				
2225	0.22×0.25	5.70×6.30				
<b>包装方式</b> Package Styles						
表示方式 Express Method			表示方式 Express Method		表示方式 Express Method	
包装方式 Package Styles			包装方式 Package Styles		包装方式 Package Styles	
B			散包装 Bulk Bag		散包装 Bulk Bag	
T			编带包装 Taping Package		编带包装 Taping Package	

<b>介质种类</b> Dielectric Code		<b>容量误差</b> Capacitance Tolerance		<b>端子材料</b> Terminal Material Styles	
介质种类 Dielectric Code	介质材料 Dielectric	代码 Code	误差 Tolerance	端子类别 Termination Styles	表示方式 Express Method
B	X7R	J	±5%	柔性端子多层片式 陶瓷电容器 MLCC with Flexiterm Solderable Termination	A
		K	±10%		
		M	±20%		

**◆产品结构**  
**Product Structure**

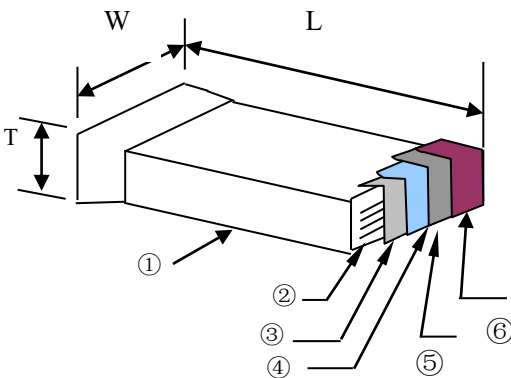
序号 NO	名称 Name	序号 NO	名称 Name
①	陶瓷介质 Ceramic dielectric	④	导电性树脂 Conductive Resin
②	内电极 Inner electrode	⑤	镍层 Nickel Layer
③	外电极 Substrate electrode	⑥	锡层 Tin Layer

**◆产品尺寸**  
**Product Dimensions**

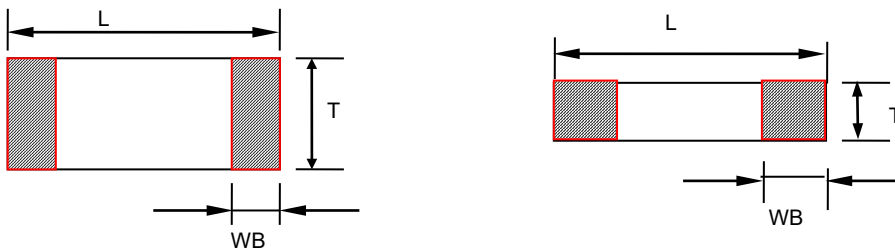
型号 Type		尺寸 Dimensions (mm)				特别说明 Special Instructions
英制表示 British	公制表示 Metric	L	W	T	WB	
0402	1005	1.00±0.05	0.50±0.05	0.50±0.05	0.25±0.05	All
0603	1608	1.60±0.10	0.80±0.10	0.80±0.10	0.35±0.20	All
0805	2012	2.00±0.20	1.25±0.20	0.80±0.20	0.50±0.20	C<1μF
		2.00±0.20	1.25±0.20	1.25±0.20	0.50±0.20	1μF≤C≤4.7μF
1206	3216	3.20±0.30	1.60±0.30	0.80±0.20	0.60±0.30	C≤330nF
		3.20±0.30	1.60±0.30	1.00±0.20	0.60±0.30	330nF<C<470nF
		3.20±0.30	1.60±0.30	1.25±0.20	0.60±0.30	470nF<C<2.2μF
		3.20±0.30	1.60±0.30	1.60±0.30	0.60±0.30	C≥2.2μF
1210	3225	3.20±0.30	2.50±0.30	≤2.80	0.60±0.30	All
1808	4520	4.50±0.40	2.00±0.20	≤2.20	0.60±0.30	All
1812	4532	4.50±0.40	3.20±0.30	≤3.50	0.60±0.30	All
2211	5728	5.70±0.40	2.80±0.40	≤3.50	0.60±0.30	All
2220	5750	5.70±0.40	5.00±0.40	≤3.50	0.60±0.30	All
2225	5763	5.70±0.50	6.30±0.50	≤6.20	0.60±0.30	All

备注：1、产品具体厚度“T”查阅本承认书中“容量范围及其电压”。2、可根据客户的特殊要求设计符合客户需求的产品。

Note: 1、The specific thickness of the product can read "capacity range and voltage" in this approval sheet.

2、We can design according to customer special requirements

### ◆ 容量范围及其电压

#### Capacitance Range and Operating Voltage

\* 常规电压 (Ur≤50V) 产品

Conventional voltage (Ur≤50V) products

材料 Dielectric	X7R														
	0402 (1.0mm*0.5mm)					0603 (1.6mm*0.8mm)					0805 (2.0mm*1.25mm)				
尺寸 Dimension															
电压 Voltage	6.3V	10V	16V	25V	50V	6.3V	10V	16V	25V	50V	6.3V	10V	16V	25V	50V
330pF	0.50±0.05					0.8±0.1					0.8±0.2				
470pF															
560pF															
680pF															
1nF															
2.2nF															
3.9nF															
4.7nF															
5.6nF															
6.8nF															
10nF															
15nF															
18nF															
22nF															
33nF															
47nF															
56nF															
68nF															
100nF															
220nF	0.50±0.05					0.8±0.2					1.25±0.2				
330nF	0.50±0.05														
470nF															
680nF	0.50±0.05														
1μF						0.8±0.2					1.25±0.2				
2.2μF															
3.3μF						0.8±0.2					1.25±0.2				
4.7μF															
6.8μF															
10μF						1.25±0.2					1.25±0.2				

备注：1、对应产品设计厚度，单位：mm 2、可根据客户的特殊要求设计符合客户需求的产品

Note: 1、Corresponding product design thickness, unit:mm 2、We can design according to customer special requirement

材料 Dielectric	X7R																	
尺寸 Dimension	1206 (3.2mm*1.6mm)					1210 (3.2mm*2.5mm)					1808 (4.5mm*2.0mm)					1812		
电压 Voltage	6.3 V	10 V	16 V	25 V	50 V	6.3 V	10 V	16 V	25 V	50 V	6.3 V	10 V	16 V	25 V	50V	16 V	25 V	50 V
330pF	0.8±0.2					1.25±0.15					1.6±0.3					1.60±0.20		
470pF																		
560pF																		
680pF																		
1nF																		
2.2nF																		
3.9nF																		
4.7nF																		
5.6nF																		
6.8nF																		
10nF																		
15nF																		
18nF																		
22nF																		
33nF																		
47nF																		
56nF																		
68nF																		
100nF																		
220nF						1.4±0.2												
330nF	1.25±0.2					1.6±0.3					1.6±0.3					2.0±0.20		
470nF																		
680nF	1.6±0.3																	
1μF																		
2.2μF																		
3.3μF																		
4.7μF																		
6.8μF																		
10μF																		
15μF																		
22μF																		
47μF																		
100μF																		

备注：1、【】对应容量的通用厚度，单位：mm

2、可根据客户的特殊要求设计符合客户需求的产品

Note: 1、【】 General thickness corresponds to the capacity, unit: mm

2、We can design according to the customer requirements.

\* 中高压产品

Medium and high voltage products

材料 Dielectric	X7R										
尺寸 Dimension	0402 (1.0mm*0.5mm)	0603 (1.6mm*0.8mm)			0805 (2.0mm*1.2mm)						
电压 Voltage	100V	100V	200V	250V	100V	200V	250V	500V	630V	1000V	2000V
100pF											
120pF											
150pF											
180pF											
220pF											
270pF											
330pF											
390pF											
470pF											
560pF											
680pF											
1nF											1.25±0.20
1.5nF											
1.8nF											
2.2nF	0.5±0.05	0.8±0.10	0.8±0.10		0.8±0.20		1.25±0.20	1.25±0.20	1.25±0.20	1.25±0.20	
2.7nF											
3.3nF											
4.7nF											
5.6nF											
10nF							0.8±0.20				
15nF											
18nF							1.25±0.20				
22nF											
33nF											
47nF											
56nF											
68nF											
100nF											
220nF											
330nF							1.25±0.20				
470nF											
680nF											
1μF											
2.2μF											
3.3μF											
4.7μF											
6.8μF											
10μF											

备注：1、【】对应容量的通用厚度，单位：mm

2、可根据客户的特殊要求设计符合客户需求的产品

Note: 1、【】 General thickness corresponds to the capacity, unit: mm

2、We can design according to the customer requirements.



材料 Dielectric	X7R											
尺寸 Dimension	1206 (3.2mm*1.6mm)											
电压 Voltage	100V	200V	250V	500V	630V	1000V	2000V	2500V				
100pF	0.80±0.20	0.80±0.20		0.80±0.20	1.25±0.20	1.60±0.30	1.25±0.20					
120pF												
150pF												
180pF												
220pF												
270pF												
330pF												
390pF												
470pF												
560pF												
680pF												
1nF												1.25±0.20
1.5nF												
1.8nF												
2.2nF								0.80±0.20				
2.7nF												
3.3nF												
4.7nF												
5.6nF												
6.8nF												
10nF				1.25±0.20	1.25±0.20		1.60±0.30					
15nF												
18nF												
22nF												
33nF					1.60±0.30							
47nF												
56nF		1.25±0.20	1.25±0.20									
68nF				1.60±0.30								
100nF	1.25±0.20											
220nF		1.60±0.30	1.60±0.30									
330nF												
470nF												
680nF	1.60±0.30											
1μF												
2.2μF												
3.3μF												
4.7μF												
6.8μF												
10μF												

备注：1、【】对应容量的通用厚度，单位：mm

2、可根据客户的特殊要求设计符合客户需求的产品

Note: 1、【】 General thickness corresponds to the capacity, unit: mm

2、We can design according to the customer requirements.

材料 Dielectric	X7R														
尺寸 Dimension	1210 (3.2mm*2.5mm)							1808 (4.2mm*5.0mm)							
电压 Voltage	100V	200V	250 V	500V	630V	1KV	2KV	100V	250V	500V	1KV	2KV	3KV	4KV	5KV
100pF															
120pF															
150pF															
180pF															
220pF						1.25 ± 0.20	1.25 ± 0.20								
270pF															
330pF															
390pF															
470pF								1.60 ± 0.30							
560pF															
680pF															
1nF															
1.5nF															
1.8nF															
2.2nF															
2.7nF															
3.3nF															
4.7nF															
5.6nF															
6.8nF															
10nF															
15nF															
18nF	1.25 ± 0.20														
22nF															
33nF															
47nF															
56nF															
68nF															
100nF															
220nF															
330nF	1.60 ± 0.30														
470nF															
680nF															
1μF															
2.2μF	2.5± 0.30														
3.3μF															
4.7μF															
6.8μF															
10μF															

备注：1、【】对应容量的通用厚度，单位：mm

2、可根据客户的特殊要求设计符合客户需求的产品

Note: 1、【】 General thickness corresponds to the capacity, unit: mm

2、We can design according to the customer requirements.

材料 Dielectric	X7R									
尺寸 Dimension	1812 (4.5mm*3.2mm)									
电压 Voltage	100V	200V	250V	500V	630V	1KV	2KV	3KV	4KV	5KV
100pF										
120pF										
150pF										
180pF										
220pF										
270pF										
330pF										
390pF										
470pF										
560pF										
680pF										
1nF										
1.5nF										
1.8nF										
2.2nF										
2.7nF										
3.3nF										
4.7nF										
5.6nF										
6.8nF										
10nF										
15nF										
18nF										
22nF										
33nF										
47nF										
56nF										
68nF										
100nF										
220nF										
330nF										
470nF										
680nF										
1μF										
2.2μF										
3.3μF										
4.7μF										
6.8μF										
10μF										

备注：1、【】对应容量的通用厚度，单位：mm

2、可根据客户的特殊要求设计符合客户需求的产品

Note: 1、【】 General thickness corresponds to the capacity, unit: mm

2、We can design according to the customer requirements.

材料 Dielectric	X7R								
尺寸 Dimension	1825 (4.5mm*6.3mm)						2211 (5.7mm*2.8mm)		
电压 Voltage	200V	250V	500V	630V	1000V	2000V	3000V	3000V	5000V
100pF									
120pF									
150pF									
180pF									
220pF									
270pF									
330pF									
390pF									
470pF									
560pF									
680pF									
1nF									
1.5nF									
1.8nF									
2.2nF								1.6±0.30	
2.7nF									
3.3nF									
3.9nF									
4.7nF						1.6±0.30	1.8±0.30		
5.6nF							2.0±0.30		
6.8nF									
10nF									
15nF									
18nF									
22nF					1.6±0.30				
33nF									
47nF									
56nF									
68nF									
100nF	1.6±0.30		1.6±0.30		2.0±0.30				
120nF									
150nF				1.6±0.30					
220nF									
330nF									
470nF									
680nF									
1 μF									
2.2 μF									
3.3 μF									
4.7 μF									
6.8 μF									
10 μF		2.0±0.30							

备注：1、【】对应容量的通用厚度，单位：mm

2、可根据客户的特殊要求设计符合客户需求的产品

Note: 1、【】 General thickness corresponds to the capacity, unit: mm

2、We can design according to the customer requirements.

材料 Dielectric	X7R										
尺寸 Dimension	2220 (5.7mm*6.3mm)										
电压 Voltage	100V	200V	250V	500V	630V	1000V	2000V	2500V	3000V	4000V	50000V
100pF											
120pF											
150pF											
180pF											
220pF											
270pF											
330pF											
390pF											
470pF											
560pF											
680pF											
1nF											
1.5nF											1.60 ±0.30
1.8nF											
2.2nF											
2.7nF											
3.3nF											2.0 ±0.30
3.9nF									1.60 ±0.30	1.60 ±0.30	
4.7nF											
5.6nF											
6.8nF											
8.2nF											
10nF									1.60 ±0.30		
15nF											
18nF											
22nF											
33nF											
47nF											
56nF											
68nF											
100nF											
120nF											
150nF											
220nF											
330nF											
470nF	1.60 ±0.30										
680nF	1.60 ±0.30										
1μF	1.60 ±0.30										
2.2μF	1.80 ±0.30										
3.3μF	2.0 ±0.30										
4.7μF											
6.8μF											
10μF											

备注：1、【】对应容量的通用厚度，单位：mm

2、可根据客户的特殊要求设计符合客户需求的产品

Note: 1、【】 General thickness corresponds to the capacity, unit: mm

2、We can design according to the customer requirements.

材料 Dielectric	X7R									
尺寸 Dimension	2225 (5.7mm*5.0mm)									
电压 Voltage	100V	200V	250V	500V	1000V	1500V	2000V	3000V	4000V	5000V
100pF										
120pF										
150pF										
180pF										
220pF										
270pF										
330pF										
390pF										
470pF										
560pF										
680pF										
1nF										
1.5nF								1.60 ±0.30		1.60 ±0.30
1.8nF										
2.2nF									1.8± 0.30	
2.7nF					1.60 ±0.30					
3.3nF										
3.9nF										
4.7nF										
5.6nF								1.60 ±0.30		
6.8nF										
10nF										
15nF										
18nF										
22nF								1.8± 0.30		
33nF			1.60 ±0.30				2.0± 0.30			
47nF				1.60± 0.3			1.8± 0.30			
56nF										
68nF					1.8± 0.30		2.0± 0.30			
100nF						2.0± 0.30				
120nF					2.0± 0.30					
150nF	1.60 ±0.30									
220nF										
330nF										
470nF		1.60 ±0.30								
680nF				2.0± 0.30						
1μF			2.0± 0.30	3.2± 0.30						
2.2μF										
3.3μF										
4.7μF										
6.8μF										
10μF										

备注：1、【】对应容量的通用厚度，单位：mm

2、可根据客户的特殊要求设计符合客户需求的产品

Note: 1、【】 General thickness corresponds to the capacity, unit: mm

2、We can design according to the customer requirements.

**◆ 可靠性测试**  
**Reliability Test**

项目 Item	技术规格 Technical Specification	测试方法 Test Method and Remarks					
容量 Capacitance	应符合指定的误差级别 Should be within the specified tolerance.	测试温度: 25°C±3°C Test Temperature: 25°C±3°C C≤10μF: 测试频率: 1KHz±10%      测试电压: 1.0±0.2Vrms Test Frequency: 1KHz±10%      Test Voltage: 1.0±0.2Vrms C>10μF 测试频率: 120±24 Hz      测试电压: 0.5±0.1Vrms Test Frequency: 120±24 Hz      Test Voltage: 0.5±0.1Vrms					
绝缘电阻 (IR) Insulation Resistance	C≤25 nF, Ri≥10000MΩ C>25 nF, Ri·CR>100S	测试电压: 额定电压 (最高 500V) 测试时间: 60±5 秒      测试湿度: ≤75% 测试温度: 25°C±3°C      测试充放电电流: ≤50mA Measuring Voltage: Rated Voltage (Max 500V) Duration: 60±5s      Test Humidity: ≤75% Test Temperature: 25°C±3°C      Test Current: ≤50mA					
损耗角正切 (DF, tanδ) Dissipation Factor	电压	DF(×10 <sup>-4</sup> )	0402	0603	0805	1206 及以上	
	50V	≤250	≤10nF	<100nF	—	≤680nF	
		≤350	≤47nF	<470nF	≤1uF	≤2.2uF	
		≤500	≤0.1μF	—	—	—	
		≤750	—	—	≤2.2uF	≤4.7uF	
		≤1000	—	≤1μF	≤1μF	≤10μF	
	25V	≤250	≤10nF	<100nF	—	≤680nF	
		≤350	≤47nF	<470nF	≤1uF	—	
		≤500	0.22μF	—	—	—	
		≤750	—	—	≤2.2μF	≤10μF	
		≤1000	—	≤2.2μF	≤4.7μF	—	
	16V	250	≤10nF	<100nF	—	≤680nF	
		≤350	≤47nF	<470nF	≤1uF	—	
		≤500	≤220nF	—	—	—	
		≤750	—	—	≤4.7μF	≤10μF	
		≤1000	≤470nF	≤2.2μF	≤4.7μF	—	
	10V	≤250	≤10nF	<100nF	—	≤680nF	
		≤350	≤47nF	<470nF	≤1uF	—	
		≤500	≤220nF	—	—	—	
		≤750	—	—	≤2.2μF	≤10μF	
		≤1000	≤1μF	≤2.2μF	≤4.7μF	—	
	≤6.3V	≤250	≤10nF	<100nF	—	≤680nF	
		≤350	47nF	<470nF	≤1uF	—	
		≤500	≤220nF	—	—	—	
		≤750	—	—	≤2.2uF	≤10μF	
		≤1000	≤1μF	≤4.7μF	≤10μF	—	

C≤10μF  
 测试频率: 1KHz±10%  
 测试电压: 1.0±0.2Vrms  
 Test Frequency: 1KHz±10%  
 Test Voltage: 1.0±0.2Vrms  
 C>10μF  
 测试频率: 120±24 Hz  
 测试电压: 0.5±0.1Vrms  
 Test Frequency: 120±24 Hz  
 Test Voltage: 0.5±0.1Vrms

项目 Item	技术规格 Technical Specification		测试方法 Test Method and Remarks
耐焊接热 Resistance to Soldering Heat	项目 Item	II类	将电容在 100~200℃ 的温度下预热 60~120 秒。 浸锡温度: 265±5℃ 浸锡时间: 10±1s 然后取出溶剂清洗干净, 在 10 倍以上的显微镜底下观察。 试验后放置时间: 24±2h。 放置条件: 室温 Preheating conditions: 100 to 200℃; 60~120s. Solder Temperature: 265±5℃ Duration: 10±1s Clean the capacitor with solvent and examine it with a 10X(min.) microscope. Recovery Time: 24±2h. Recovery condition: Room temperature
	ΔC/C	±15%	
	DF	同初始标准 Same to initial value.	
	IR	同初始标准 Same to initial value.	
外观: 无可见损伤 上锡率: ≥95% Appearance: No visible damage. At least 95% of the terminal electrode is covered by new solder.			
抗弯曲强度 Resistance to Flexure of Substrate (Bending Strength)	外观: 无可见损伤。 Appearance: No visible damage.		试验基板: PCB 弯曲深度: 3mm 施压速度: 1mm/sec. 单位: mm 应在弯曲状态下进行测量。 Test Board: PCB Warp: 3mm Speed: 1mm/sec. Unit: mm The measurement should be made with the board in the bending position.
	ΔC/C: II类: ≤±10% Class II: ≤±10%		
端头结合强度 Termination Adhesion	外观无可见损伤 No visible damage.		如图所示: 慢慢施加一个 T 的力到电容侧面瓷体上, 并保持 60+1 秒。 As shown in the picture, Slowly apply a T force to the porcelain body on the side of the capacitor and hold for 60+1 seconds.
温度循环 Temperature Cycle	项目 Item	II类	预处理* (II类): 上限类别温度, 1 小时 恢复: 24±1h Preheating conditions: up-category temperature, 1h Recovery time: 24±1h 初始测量 Initial Measurement 循环次数: 5 次, 一个循环分以下 4 步: Cycling Times: 5 times, 1 cycle, 4 steps:
	ΔC/C	-15% ~+15%	
	外观无可见损伤 No visible damage.		
可焊性 Solderability	上锡率应大于 95% 外观: 无可见损伤。 At least 95% of the terminal electrode is covered by new solder. Visual Appearance: No visible damage.		有铅焊料: (Sn/Pb: 63/37) 无铅焊料: 浸锡温度: 235±5℃ 浸锡温度: 245±5℃ 浸锡时间: 2±0.5s 浸锡时间: 2±0.5s Pb-Sn soldering Lead-free soldering Solder Temperature: 235±5℃ Solder Temperature: 235±5℃ Duration: 2±0.5s Duration: 2±0.5s

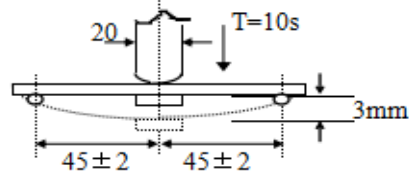

规格	施加力 T
≤0402	2N
≥0603	5N

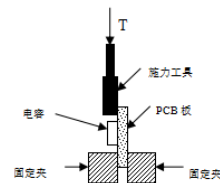

阶段 Step	温度 (Temperature) (°C)	时间 (Time)
1	下限温度 (Low-category temp.): -55	30min
2	常温 (Normal temp.): +20°C	2~3min
3	上限温度 (Up-category temp.): +125	30min
4	常温 (Normal temp.): +20°C	2~3min



项目 Item	技术规格 Technical Specification		测试方法 Test Method and Remarks												
耐湿负荷 Humidity load	$\Delta C/C$	$\leq \pm 12.5\%$	※预处理（II类）：在 140°C~150°C 下预热 1h±10min 后，在室温下放置 24±2h。 温度：40±2°C 湿度：90~95%RH 电压：额定电压 时间：500 小时 放置条件：室温 放置时间：24±2h 小时； II类：0201≥47nF、0402≥33nF、0603≥1μF、0805≥4.7μF、1206≥10μF 产品试验后需在 150°C 温度下保持 1h，再放置 24±2h 后测试电性能。 ※ Pretreatment (Class II) : After preheating at 140°C~150°C for 1h±10min, place at room temperature for 24±2h. Temperature: 40±2°C Humidity: 90~95%RH Voltage: Rated Voltage Duration: 500h Recovery conditions: Room temperature Recovery Time: 24h±2h Class 2: 0201≥47nF、0402≥33nF、0603≥1μF、0805≥4.7μF、1206≥10μF product need to keep in 150°C、1h after the test, and measurement to be made after being kept at room temperature for 24±2h.												
	DF	≤2 倍初始标准 Not more than twice of initial value.													
	IR	$R_i \geq 1000M\Omega$ 或 $R_i \cdot C_R \geq 10S$ 取两者之中较小者。 $R_i \geq 1000M\Omega$ 或 $R_i \cdot C_R \geq 10S$ whichever is smaller.													
	外观：无损伤 Appearance: No visible damage.														
寿命试验 Life Test	$\Delta C/C$	-20% ~ +20%	※预处理（II类）：在 140°C~150°C 下预热 1h±10min 后，在室温下放置 24±2h。 温度：125°C (X7R) 充电电流：不应超过 50mA。 时间：1000 小时 电压： 低压产品 (<100V) 2 倍额定工作电压，除表 1 外 100V≤额定电压≤200V：1.5 倍工作电压 200V<额定电压≤500V：1.3 倍工作电压 500V<额定电压：1.2 倍工作电压 放置条件：室温 放置时间：24±2h 小时； II类：0201≥47nF、0402≥33nF、0603≥1μF、0805≥4.7μF、1206≥10μF 产品试验后需在 150°C 温度下保持 1h，再放置 24±2h 后测试电性能。 ※ Pretreatment (ClassII) :After preheating at 140°C~150°C for 1h±10min, place at room temperature for 24±2h. Temperature:125°C (X7R) Charge/Discharge Current:50mA max. Time:1000h. Applied Voltage:1.Low voltage products (< 100V) 2 times rated operating voltage, except Table 1. 2. Medium and high pressure products: 100V≤Rated Voltages≤200V: 1.5 Multiple 200V<Rated Voltage≤500V: 1.3 Multiple 500V<Rated Voltage: 1.2 Multiple Recovery Conditions: Room Temperature Recovery Time: 24h±2h Class 2: 0201≥47nF、0402≥33nF、0603≥1μF、0805≥4.7μF、1206≥10μF product need to keep in 150°C、1h after the test, and measurement to be made after being kept at room temperature for 24±2h.												
	DF	≤2 倍初始标准 Not more than twice of initial value.													
	IR	$R_i \geq 2000M\Omega$ 或 $R_i \cdot C_R \geq 50S$ 取两者之中较小者。 $R_i \geq 2000M\Omega$ 或 $R_i \cdot C_R \geq 50S$ whichever is smaller.													
	外观：无损伤 Appearance: No visible damage.														
			表 1(table 1) <table border="1" style="width: 100%; text-align: center;"> <thead> <tr> <th>容量</th> <th>试验电压</th> <th>容量</th> <th>试验电压</th> </tr> </thead> <tbody> <tr> <td>0201≥10nF</td> <td rowspan="3">1.5Ur</td> <td>0805≥0.47uF</td> <td rowspan="3">1.5Ur</td> </tr> <tr> <td>0402≥47nF</td> <td>1206≥1uF</td> </tr> <tr> <td>0603≥220nF</td> <td>1210≥1uF</td> </tr> </tbody> </table>	容量	试验电压	容量	试验电压	0201≥10nF	1.5Ur	0805≥0.47uF	1.5Ur	0402≥47nF	1206≥1uF	0603≥220nF	1210≥1uF
容量	试验电压	容量	试验电压												
0201≥10nF	1.5Ur	0805≥0.47uF	1.5Ur												
0402≥47nF		1206≥1uF													
0603≥220nF		1210≥1uF													

注解：

专门预处理\*（仅对 2 类电容器）：将电容器放在上限类别温度或按详细规范中可能规定的更高温度下经 1h 后，接着在试验的标准大气条件下恢复 24±1h。

Note:

Pretreatment (only for class2 capacitor) Pretreatment (only for class2 capacitor) is a method to treat the capacitor before measurement. First, place the capacitor in the up-category temperature or other specified higher temperature environment for 1hour. Then recovery the capacitor at standard pressure conditions for 24±1hours.

项目 Item	技术规格 Technical Specification	测试方法 Test Method and Remarks	
介质耐电强度 (DWV) Dielectric Withstanding Voltage	不应有介质被击穿或损伤 No breakdown or damage.	Ur < 100V	测量电压: I类: 300% Ur      II类: 250% Ur 时间: 1~5 秒    充/放电电流: 不应超过 50mA。 Measuring Voltage: I class: 300% Ur      II class : 250% Ur Duration: 1~5s      Charge/ Discharge Current: 50mA max.
		100V ≤ Ur < 500V	施加额定电压的 200%, 5 秒, 最大电流不超过 50mA Force 200% Rated voltage for 5 second. Max. current should not exceed 50 mA.
		500V ≤ Ur ≤ 1000V	施加额定电压的 150%, 5 秒, 最大电流不超过 50mA Force 150% Rated voltage for 5 second. Max. current should not exceed 50 mA.
		1000V < Ur ≤ 2000V	施加额定电压的 120%, 5 秒, 最大电流不超过 50mA Force 120% Rated voltage for 5 seconds. Max. current should not exceed 50 mA.
		2000V < Ur ≤ 5000V	施加额定电压的 120%, 5 秒, 最大电流不超过 10mA Force 120% Rated voltage for 5 seconds. Max. current should not exceed 10 mA.

### ◆ 包装 Package

#### \* 纸带卷盘结构 Paper Taping

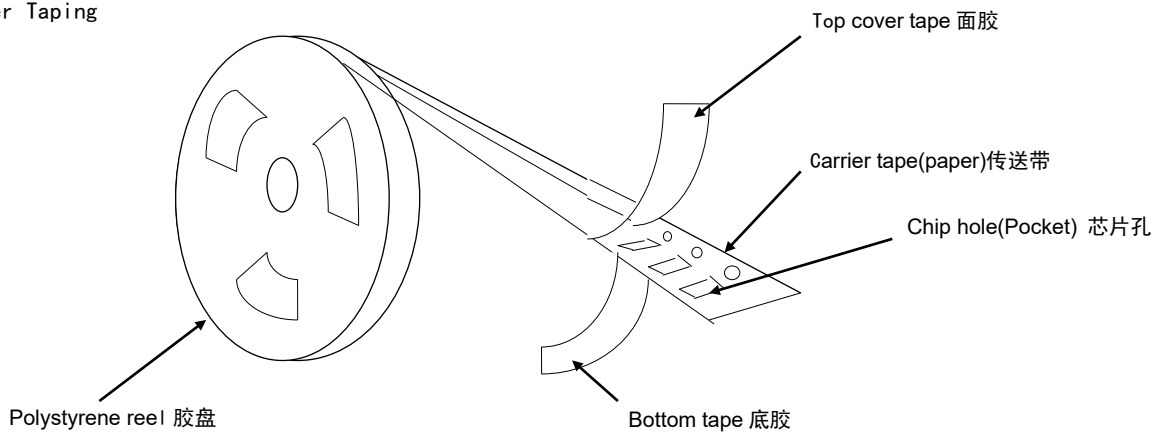

#### \* 0402 纸带编带尺寸大小 Dimensions of paper taping for 0402 type

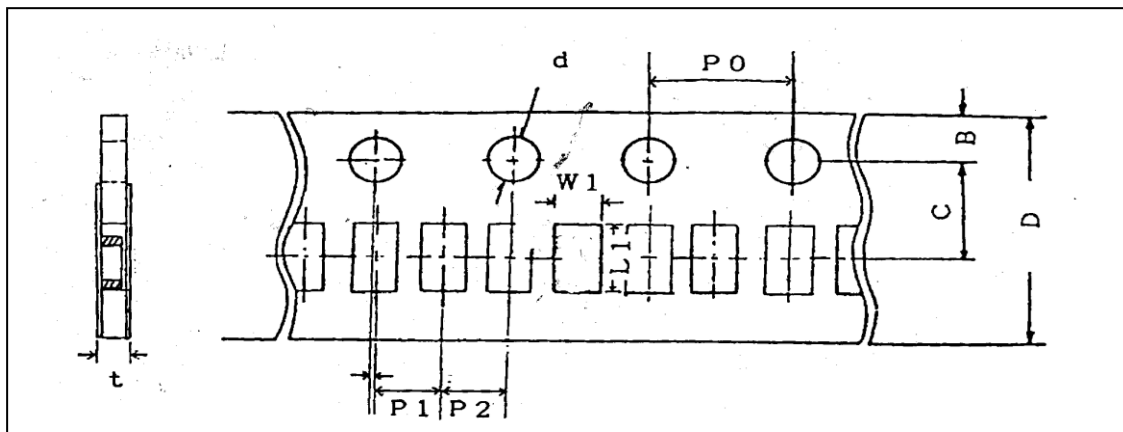

代号 Code	W1	L1	D	C	B	P1	P2	P0	d	t
0402	0.65± 0.10	1.15± 0.10	8.00± 0.10	3.50± 0.05	1.75± 0.10	2.00± 0.05	2.00± 0.05	4.00±0 .10	1.50 -0/+0.10	0.80 Below

#### \* 适合 '0603, 0805, 1206' 常规尺寸产品的纸带尺寸 Dimensions of paper taping for 0603, 0805, 1206 types.

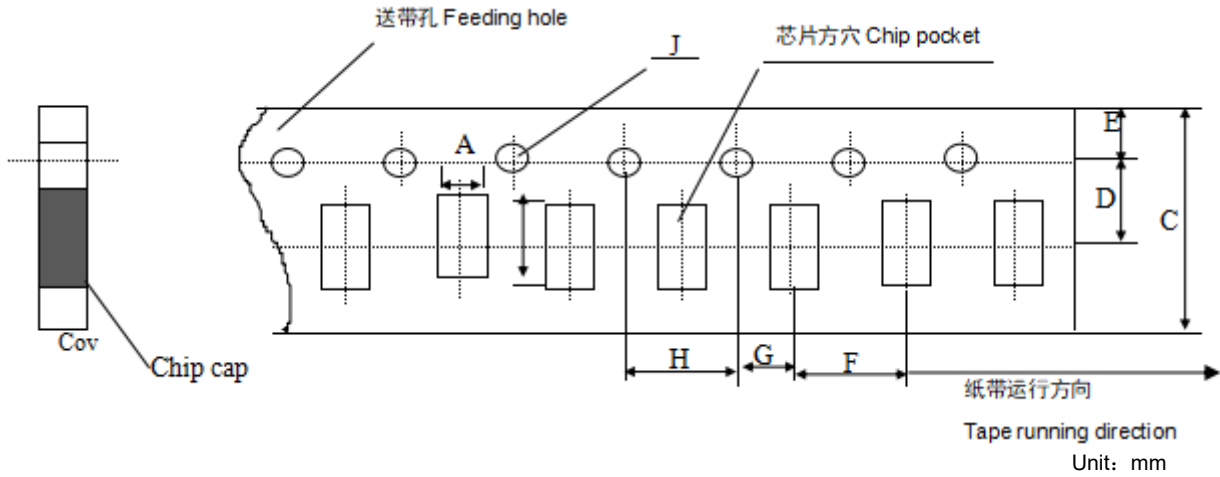

代号Code 纸带规格 paper size	A	B	C	D*	E	F	G*	H	J	T
0603	1.10 ±0.10	1.90 ±0.10	800 ±0.10	3.50 ±0.05	1.75 ±0.10	4.00 ±0.10	200 ±0.10	4.00 ±0.10	1.50 -0/+0.10	1.10 Max
0805	1.45 ±0.15	2.30 ±0.15	80 ±0.15	3.50 ±0.05	1.75 ±0.10	4.00 ±0.10	200 ±0.10	4.00 ±0.10	1.50 -0/+0.10	1.10 Max
1206	1.80 ±0.20	3.40 ±0.20	800 ±0.20	3.50 ±0.05	1.75 ±0.10	4.00 ±0.10	200 ±0.10	4.00 ±0.10	1.50 -0/+0.10	1.10 Max

注意：\*表示此处对尺寸的要求非常精确。  
Note: The place with "\*" means where needs exactly dimensions.

\* 塑胶卷盘结构  
Embossed taping

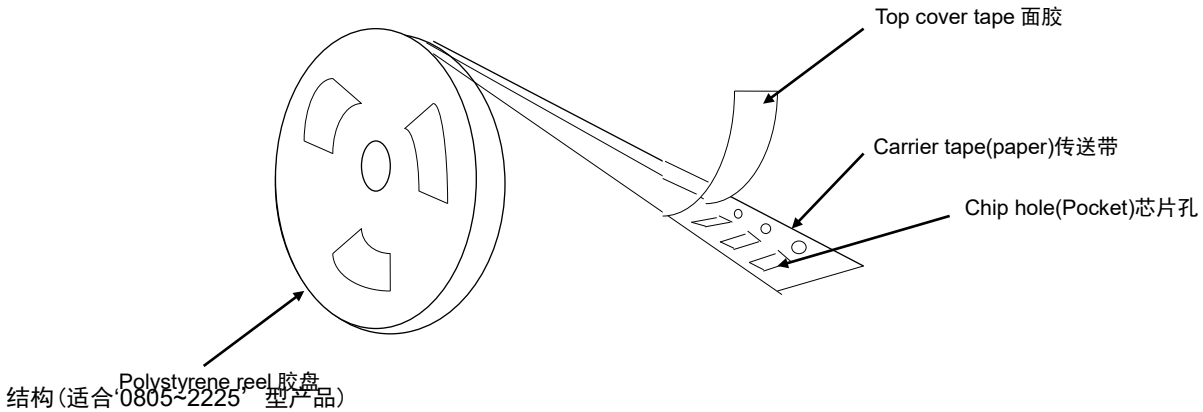

Dimensions of embossed taping for 0805~2225 type

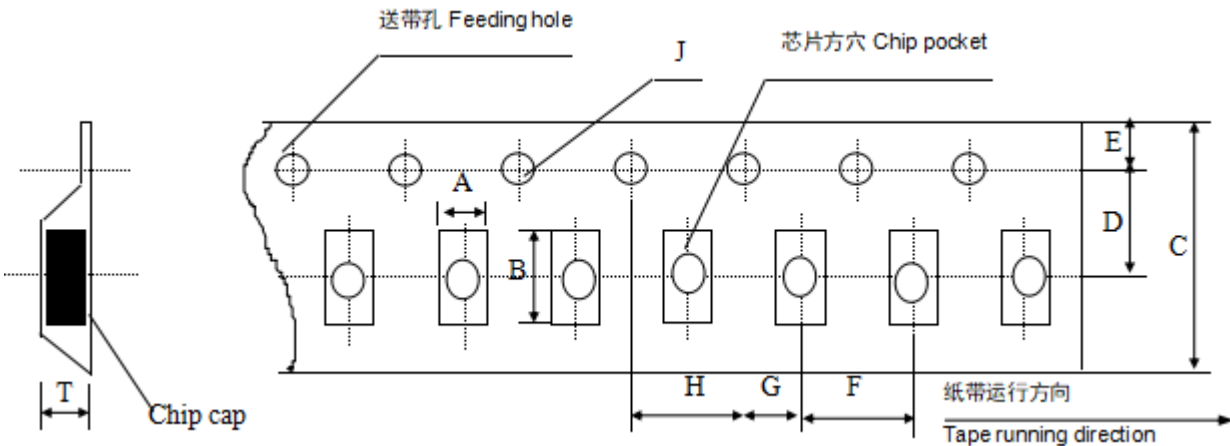

代号 Code 规格 Tape size	A	B	C	D*	E	F	G*	H	J	T
0805	1.55 ± 0.20	2.35 ± 0.20	8.00 ± 0.20	3.50 ± 0.05	1.75 ± 0.10	4.00 ± 0.10	2.00 ± 0.10	4.00 ± 0.10	1.50 -0/+0.10	1.50 Max
1206	1.95 ± 0.20	3.60 ± 0.20	8.00 ± 0.20	3.50 ± 0.05	1.75 ± 0.10	4.00 ± 0.10	2.00 ± 0.10	4.00 ± 0.1	1.50 -0/+0.10	1.85 Max
1210	2.70 ± 0.10	3.42 ± 0.10	8.00 ± 0.10	3.50 ± 0.05	1.75 ± 0.10	4.00 ± 0.10	2.00 ± 0.05	4.00 ± 0.10	1.55 -0/+0.10	3.2 Max
1808	2.20 ± 0.10	4.95 ± 0.10	12.00 ± 0.10	5.50 ± 0.05	1.75 ± 0.10	4.00 ± 0.10	2.00 ± 0.05	4.00 ± 0.10	1.50 -0/+0.10	3.0 Max
1812	3.66 ± 0.10	4.95 ± 0.10	12.00 ± 0.10	5.50 ± 0.05	1.75 ± 0.10	8.00 ± 0.10	2.00 ± 0.05	4.00 ± 0.10	1.55 -0/+0.10	4.0 Max
2211/ 2220/2225	6.2 ±0.1	6.7 ±0.1	12.00 ± 0.10	5.50 ± 0.05	1.75 ± 0.10	8.00 ± 0.10	2.00 ± 0.05	4.00 ± 0.10	1.55 -0/+0.10	2.4 ± 0.10

备注：\*表示此处对尺寸的要求非常精确。

Note: The place with "\*" means where needs exactly dimensions.

\* 传送带的前后结构

Structure of leader part and end part of the carrier paper

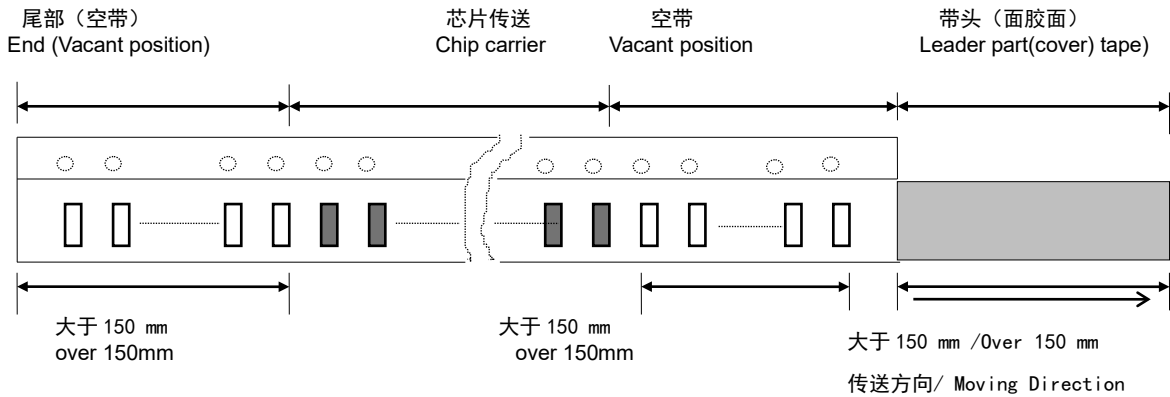

\* 卷盘尺寸

Reel dimensions (unit: mm)

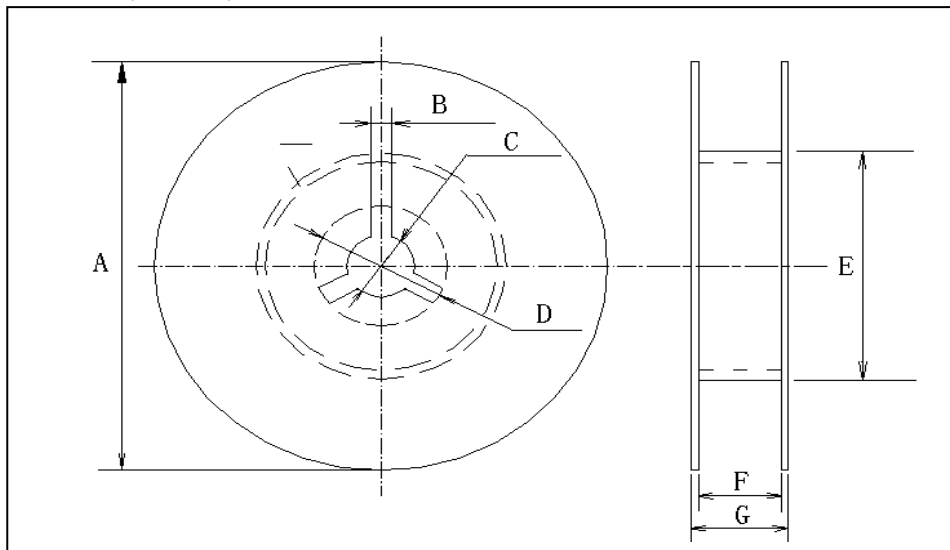

卷盘型号	A	B	C	D	E	F	G
7'REEL	φ178±2.0	3.0	φ13±0.5	φ21±0.8	φ50 或更大 φ50 or more	10.0±1.5	12max

\* 关于卷带的说明：面胶剥离强度  
Taping specification: top tape peeling strength

\* 纸带 Paper Taping

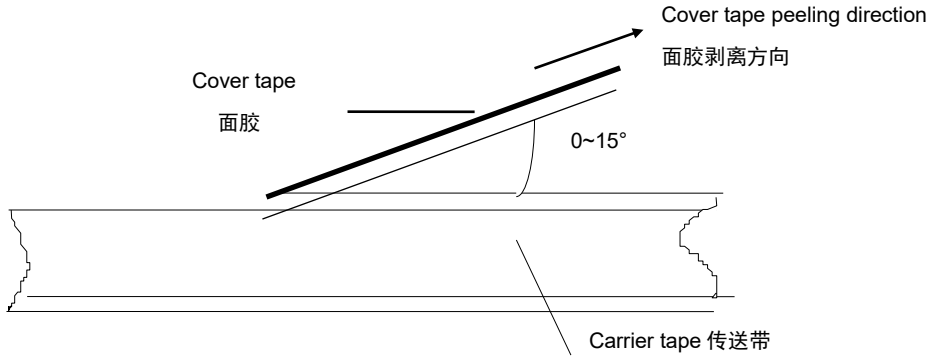

\* 塑料胶盘 Embossed Taping

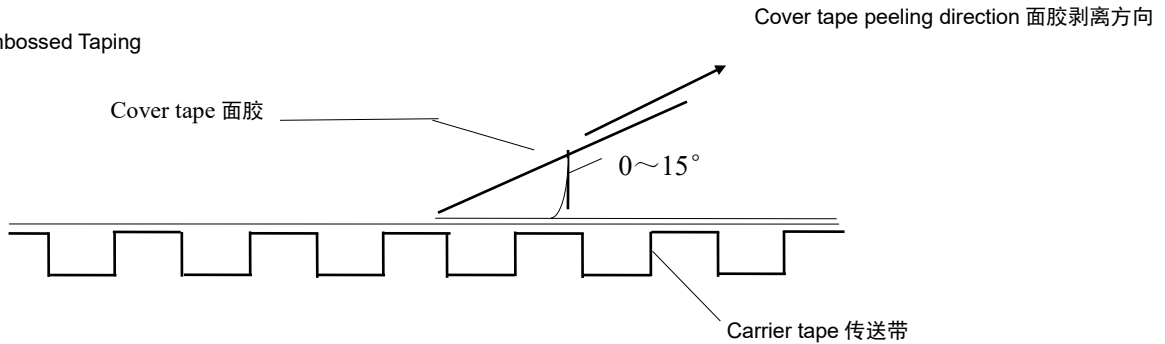

标准：0.1N < 剥离强度 < 0.7N  
Standard: 0.1N < peeling strength < 0.7N  
在剥离时，纸带不能有纸碎，也不能粘在底、面胶上。  
No paper dirty remains on the scotch when peeling, and sticks to top and bottom tape.

\* 塑料盒散包装  
Bulk Case Package

单位 (unit) :mm

Symbol	A	B	T	C	D	E
Dimension	6.80±0.10	8.80±1.00	12.00±0.10	15.00+0.10/-0	2.00+0/-0.10	4.70±0.10
Symbol	F	W	G	H	L	I
Dimension	31.50+0.20/-0	36.00+0/-0.20	19.00±0.35	7.00±0.35	110.00±0.70	5.00±0.35

**\* 包装数量**

Packing Quantity

尺寸 (SIZE)	包装形式和数量 (Package Style & Quantity) unit: pcs				
	塑料压纹带卷盘 (EPT)	纸带卷盘 (PT)	胶带卷盘 (ET)	塑料盒散装 (BC)	一般散装 (BP)
0402	-----	10000	-----	20000	5000
0603	-----	4000	-----	15000	5000
0805	-----	4000	3000	10000	5000
1206	-----	4000	T≤1.35mm 3000 T>1.35mm 2000	5000	5000
1210	-----	-----	T≤1.80mm 2000 T>1.80mm 1000	-----	2000
1808	-----	-----	2000	-----	2000
1812	-----	-----	T≤1.85mm 1000 T>1.85mm 500	-----	2000
2211、2220、2225	-----	-----	500	-----	500

注意：包装的形式和数量可根据客户的要求来定。

Note: We can choose packing style and quantity can be according to the customer's requirement.

**\* 外包装**
**Outer packing**

小包装 The first package

Quantity: 10 reels

数量：10 卷

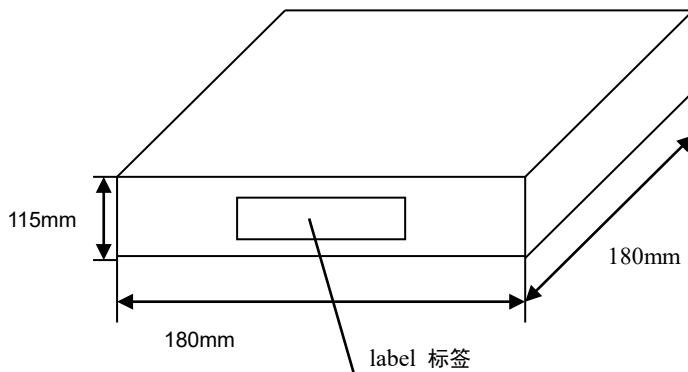

PART No 型号规格
QUANTITY 数量
DATE 日期

大包装 The second package

Quantity: 6 cases

数量：6 盒

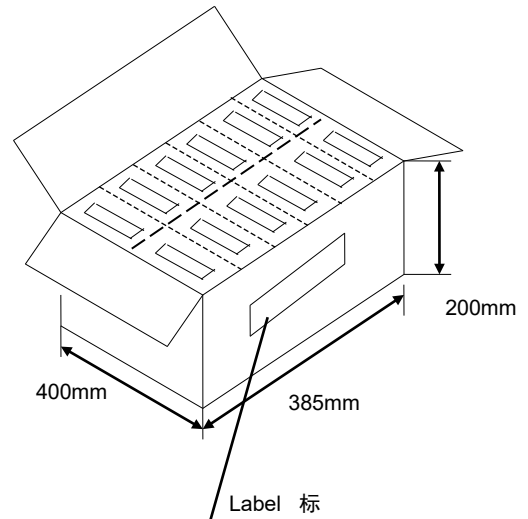

Production name 产品名称
Quantity 数量
Weight 重量

### ◆ 储存方法

#### Storage Methods

- \* 确保芯片可焊性良好的贮存期限为 12 个月 (在包装好已交付的情况下)。  
The guaranteed period for solderability is 12 months (Under deliver package condition).
- \* 储存条件 Storage conditions:  
 储存温度/Temperature 5~40°C                      储存相对湿度/Relative Humidity 20~70%

### ◆ 使用前的注意事项

#### Precautions For Use

多层片式瓷介电容器 (MLCC) 在短路或开路的电路中都有可能失效, 在超出本承诺书或相关说明书中所述使用频率的恶劣工作环境, 或外界机械力超压作用下, 电容芯片都有可能着火、燃烧甚至爆炸, 所以在使用的时候, 首先应考虑按本承诺书的有关说明来进行, 如有不明之处, 请联系我们技术部、品管部或生产部。

The Multi-layer Ceramic Capacitors (MLCC) may fail in a short circuit mode in an open circuit mode when subjected to severe conditions of electrical environment and / or mechanical stress beyond the specified "rating" and specified "conditions" in the specification, which will result in burn out, flaming or glowing in the worst case. Following "precautions for "safety" and Application Notes shall be taken in your major consideration. If you have a question about the precautions for handling, please contact our engineering section or factory.

#### \* 焊接的条件与相关图表

##### Soldering Profile

为避免因温度的突然变化而引起的芯片开裂或局部爆炸的现象发生, 请按有关温度曲线图表来进行。(请参考附页中的图表)

To avoid the crack problem by sudden temperature change, follow the temperature profile in the adjacent graph (refer to the graph in the enclosure page).

#### \* 手工焊接

##### Manual Soldering

手工焊接很容易因为芯片局部受热不均而引起瓷体微裂或局部爆炸的现象, 在焊接时, 如果操作者不小心, 会使烙铁头直接同电容芯片的瓷体部分接触, 这样很容易使电容芯片因热冲击而受损或出现其他意外. 因此, 使用电烙铁手工焊接时应仔细操作, 并对电烙铁的尖端的选择和尖端温度控制应多加小心.

Manual soldering can pose a great risk of creating thermal cracks in capacitors. The hot soldering iron tip comes into direct contact with the end terminations, and operator's careless may cause the tip of the soldering iron to come into direct contact with the ceramic body of the capacitor. Therefore the soldering iron must be handled carefully, and pay much attention to the selection of the soldering iron tip and temperature contact of the tip.

#### \* 适量的焊料

##### Optimum Solder Amount for Reflow Soldering

焊料过多  
Too much solder

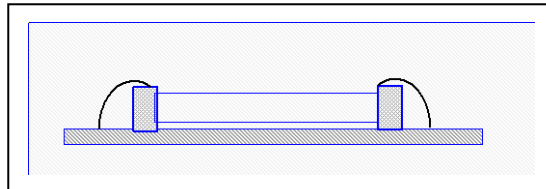

这样会因端头压力过大而可能引起芯片受损  
Cracks tend to occur due to large stress.

焊料太少  
Not enough solder

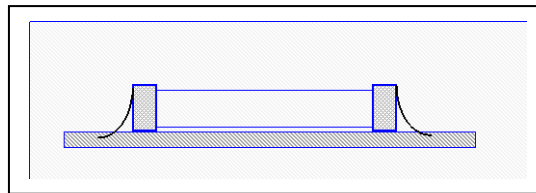

固定力量不足, 可能会引起电容芯片与线路接触不良  
Weak holding force may cause bad connection between the capacitor and PCB.

#### \* 推荐焊料用量

##### Recommended Soldering amounts

回流焊接的最佳焊料用量  
The optimal solder fillet amounts for re-flow soldering

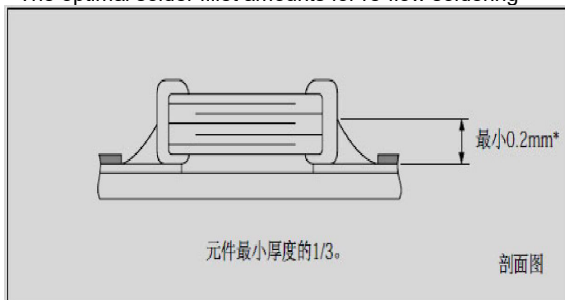

波峰焊接的最佳焊料用量  
The optimal solder fillet amounts for wave soldering

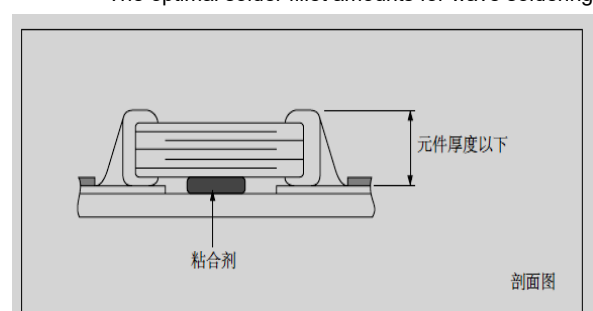

使用烙铁返修时的最佳焊料量

The optimal solder fillet amounts for reworking by using soldering iron

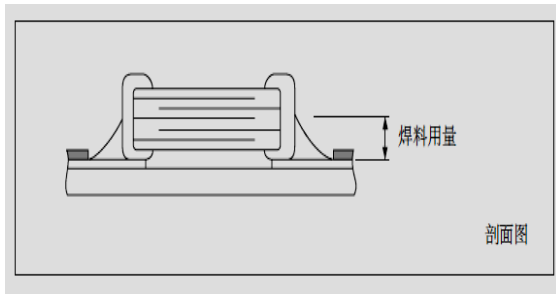

**\* 推荐焊接方式**

Recommended Soldering Method

规格尺寸 Size	温度特性 Temperature Characteristics	额定电压 Rated Voltage	容量范围 Capacitance	焊接方式 Soldering Method
0402	X7R	/	/	R
0603	X7R	/	$C \geq 1\mu\text{f}$	R
		/	$C < 1\mu\text{f}$	R/W
0805	X7R	/	$C \geq 4.7\mu\text{f}$	R
		/	$C < 4.7\mu\text{f}$	R/W
1206	X7R	/	$C \geq 10\mu\text{f}$	R
		/	$C < 10\mu\text{f}$	R/W
$\geq 1210$	X7R	/	/	R

焊接方式 Soldering method: R—回流焊 Reflow Soldering W—波峰焊 Wave Soldering

**◆ 推荐焊接温度曲线图**

**The temperature profile for soldering**

**\* 回流焊接 (Re-flow soldering)**

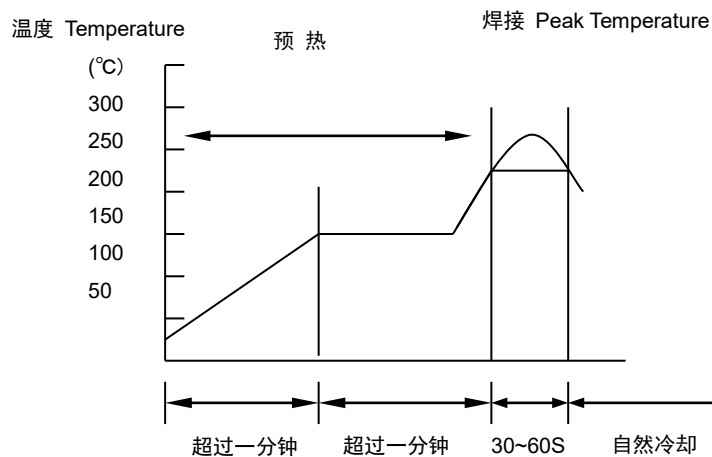

	Pb-Sn 焊接 Pb-Sn soldering	无铅焊接 Lead-free soldering
尖峰温度 Peak temperature	230°C~250°C	240°C~260°C

在预热时, 请将焊接温度与芯片表面温度之间的温差维持在  $T \leq 150^\circ\text{C}$ 。

While in preheating, please keep the temperature difference between soldering temperature and surface temperature of chips as:  $T \leq 150^\circ\text{C}$ .



\* 波峰焊接  
 (Wave soldering)

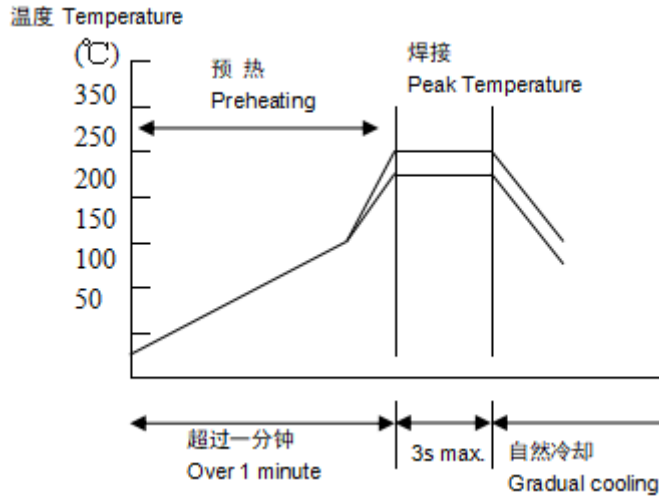

	Pb-Sn 焊接 Pb-Sn soldering	无铅焊接 Lead-free soldering
尖峰温度 Peak temperature	230°C~260°C	240°C~270°C

在预热时, 请将焊接温度与芯片表面温度之间的温差维持在  $T \leq 150^\circ\text{C}$ 。

While in preheating, please keep the temperature difference between soldering temperature and surface temperature of chips as:  $T \leq 150^\circ\text{C}$ .

\* 手工焊接  
 Hand soldering

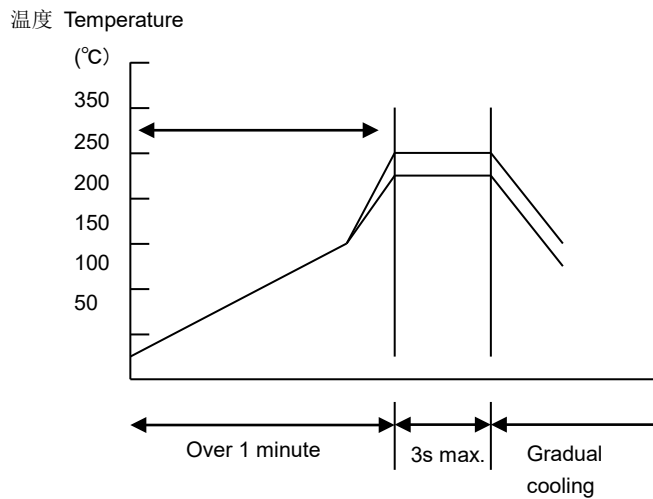

条件 Conditions:

预热 Preheating	烙铁头温度 Temperature of soldering iron head	烙铁功率 Power of soldering iron	烙铁头直径 Diameter of soldering iron head	焊接时间 Soldering time	锡膏量 Solder paste amount	限制条件 Restricted conditions
$\Delta \leq 130^\circ\text{C}$	最高 350°C Highest temperature: 350°C	最大 20W 20W at the highest	建议 1mm 1mm recommended	最长 3s 3s at the longest	$\leq 1/2$ 芯片厚度 $\leq 1/2$ chip thickness	请勿使用烙铁头直接接触陶瓷元件 Please avoid the direct contact between soldering iron head and ceramic components

\*以最新版本的内容为准