

# APPROVAL SHEET

## **RF Switch Series**

### **SP4T GPIO Diversity Switch**

Any 2G/3G/4G Antenna Diversity For Receive System

**P/N: RFASWKH4414ATF09**

\*Contents in this sheet are subject to change without prior notice.

## Approval Sheet

### FEATURES

- Low Insertion Loss : 0.55dB typ. @ 2.7GHz
- High Isolation : 28dB typ. @ 2.7GHz
- P<sub>1dB</sub> compression point : 28dBm typ. @ 2.7GHz
- Low control voltage : 1.35 to 2.7 V
- Miniature footprint : 2.0 x 2.0 x 0.55 mm<sup>3</sup>

### Description

- The RFASWKH4414ATF09 is a SOI (Silicon On Insulator) Single Pole, Four Throw (SP4T) switch that operating at 0.1-2.7 GHz. The RFASWKH4414ATF09 is manufactured in a QFN-14 (2.0x2.0x0.55mm<sup>3</sup>) package.
- The RFASWKH4414ATF09 features very high isolation with very low DC power consumption.
- The RFASWKH4414ATF09 has ESD protection devices to achieve excellent ESD performances. No DC Blocking capacitors are required for all RF ports unless DC is biased externally.

### Application

- Multi-mode 2G/3G, LTE application receive system.

### Block Diagram and Pin Out (Top View)

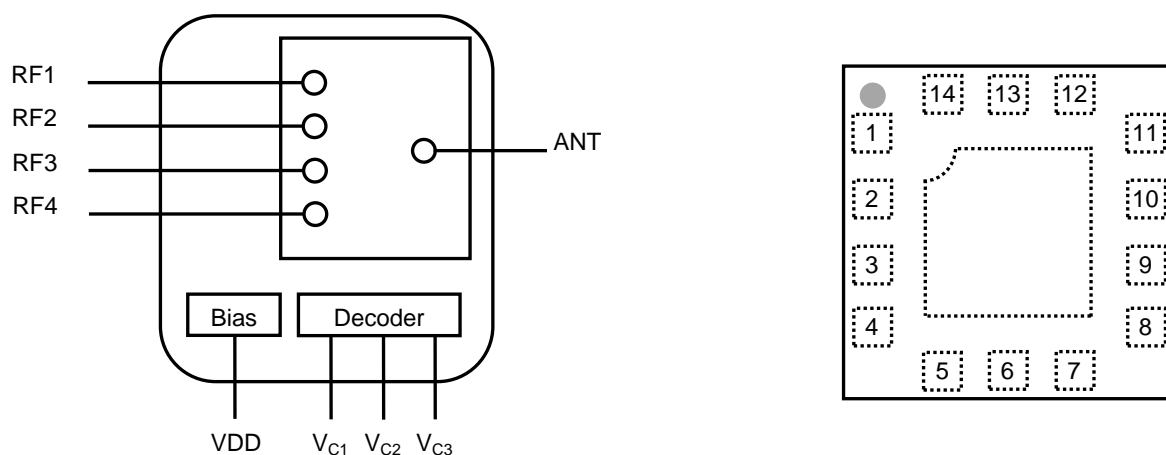

### Pin Names and Descriptions

Pin	Name	Description	Pin	Name	Description
1	RF5	RF path 5	8	NC	Not connected
2	RF3	RF path 3	9	RF2	RF path 2
3	RF1	RF path 1	10	RF4	RF path 4
4	VDD	DC power supply	11	RF6	RF path 6
5	V <sub>C3</sub>	DC control voltage 3	12	NC	Not connected
6	V <sub>C2</sub>	DC control voltage 2	13	ANT	Antenna port
7	V <sub>C1</sub>	DC control voltage 1	14	NC	Not connected

Note: Bottom ground paddles must be connected to ground.

**Approval Sheet**

**Application Circuit**

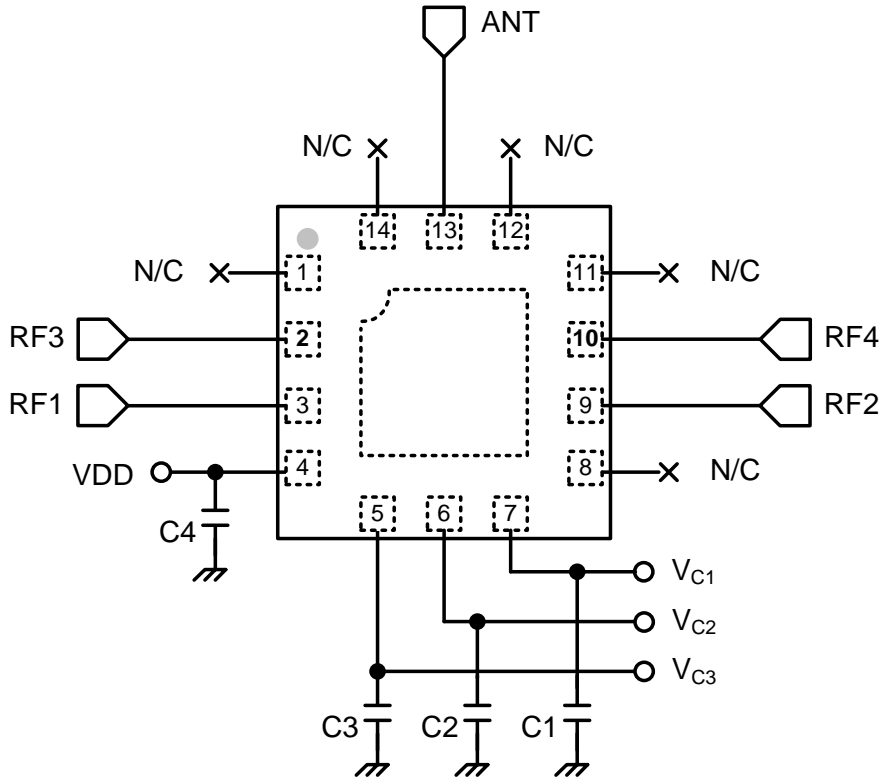

Note: No DC Blocking capacitors are required for all RF ports unless DC is biased externally.

**Parts List**

Parts No.	Value
C1-C4	1000 pF

**Absolute Maximum Ratings**

Parameter	Symbol	Minimum	Maximum	Units
RFx Input Power	Pin		+28	dBm
DC Supply Voltage	VDD	+2.5	+4.8	V
DC Control Voltage	V <sub>CTL</sub>	-0.5	+3.0	V
Storage temperature	T <sub>STG</sub>	-55	+150	°C
Operating temperature	T <sub>OP</sub>	-40	+85	°C
HBM ESD Voltage, All Pins	V <sub>ESD</sub> <sup>1</sup>	-	+1000	V

Note 1 : Human Body Model ESD Voltage, Class 1C

Exceeding absolute maximum ratings may cause permanent damage. Operation between operating range maximum and absolute maximum for extended periods may reduce reliability.

**Approval Sheet**

**Electrical Specifications**

(Top= 25°C, VDD=2.8V, V<sub>CTL</sub>=0/1.8V, Characteristic Impedance Z<sub>O</sub>= 50 Ω, Unless Otherwise Noted)

Parameter	Symbol	Test Condition	Min.	Typ.	Max.	Units
<b>RF Specifications</b>						
Operating Frequency	f		0.1		2.7	GHz
Insertion Loss (ANT port to RFx port)	IL	0.1 ~ 1.0GHz 1.0 ~ 2.0GHz 2.0 ~ 2.7GHz		0.40 0.50 0.55	0.50 0.60 0.65	dB dB
Isolation (ANT port to RFx port)	Iso	0.1 ~ 1.0GHz 1.0 ~ 2.0GHz 2.0 ~ 2.7GHz	35 28 26	38 30 28		dB dB
On State Match	VSWR	0.1 ~ 2.7GHz		1.29	1.43	-
Input Power 1dB Compression Point	P <sub>1dB</sub>	0.1 ~ 2.7GHz		+28		dBm
RFx Harmonics	2fo, 3fo	PIN = +26 dBm, CW f = 0.1 to 2.7 GHz		+94		dBc
3 <sup>rd</sup> Order Input Intercept Point	IIP3	PIN = +26 dBm, f = 2.0 GHz Δf = 1 MHz		+69		dBm
<b>DC Specification (Decoder)</b>						
Supply Voltage	VDD		2.5	2.8	4.8	V
Supply Current	I <sub>DD</sub>	VDD=2.8V		76	85	μA
Control Voltage(High)	V <sub>CTL(H)</sub>		1.35	1.8	2.7	V
Control Voltage(Low)	V <sub>CTL(L)</sub>		0		0.4	V
Control Current	I <sub>CTL</sub>	V <sub>CTL</sub> =1.8V		0.5	1.0	μA
<b>Switching Specification</b>						
Switching speed	T <sub>SW</sub>	50% V <sub>CTL</sub> to 90/10% RF		1.75	2.20	μs

Note : All measurements made in a 50Ω system with 0/+1.8V control voltages, unless otherwise specified.

**Logic Table for Switch On-Path (High=1.8V ,Low= 0V)**

V <sub>C1</sub>	V <sub>C2</sub>	V <sub>C3</sub>	RF1	RF2	RF3	RF4
0	0	0	On	Off	Off	Off
0	0	1	Off	On	Off	Off
0	1	0	Off	Off	On	Off
0	1	1	Off	Off	Off	On
1	x	x	Off	Off	Off	Off

**Approval Sheet**

**Package Dimensions**

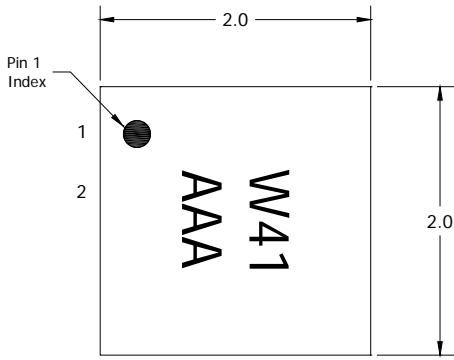

Top View

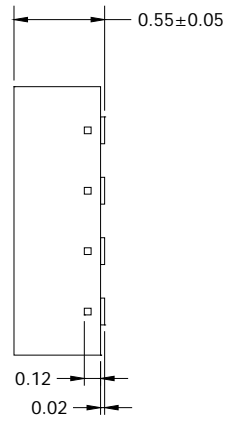

Side View

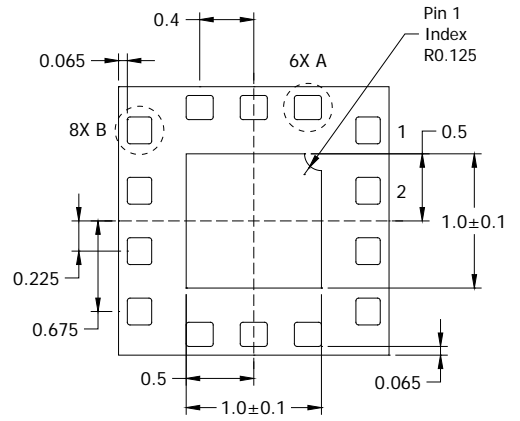

Bottom View

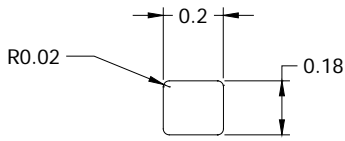

Detail A  
Scale: 2X

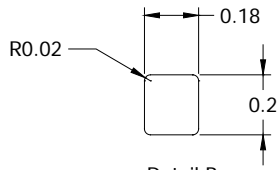

Detail B  
Scale: 2X

Unit: mm

**Solder Land Pattern**

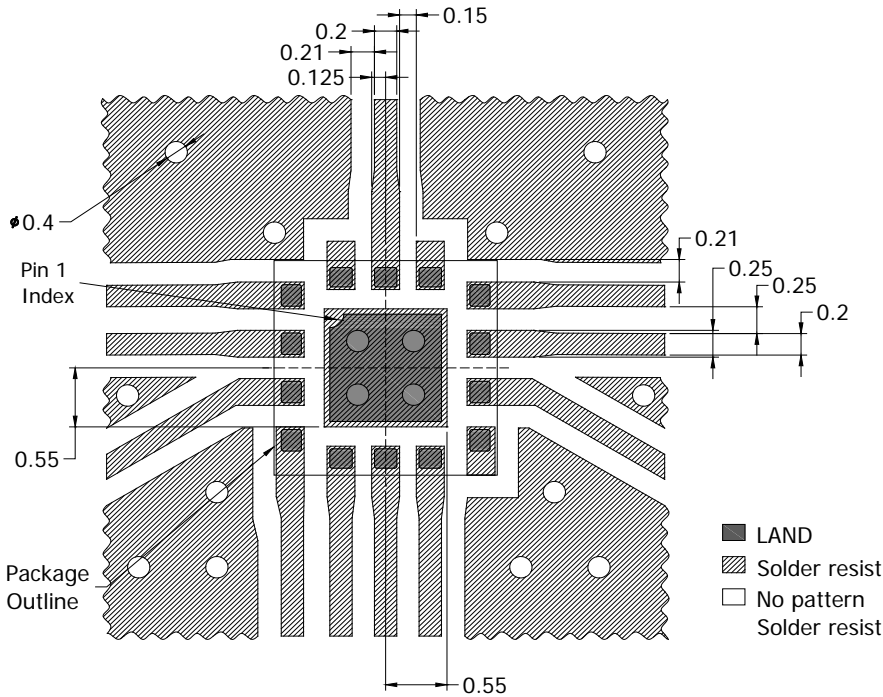

Unit : mm

Line width to be designed to match 50 Ω characteristic impedance, depending on PCB material and thickness.

**Approval Sheet**

**Reliability test**

TEST	PROCEDURE / TEST METHOD	REQUIREMENT
Solderability JIS C 0050-4.6 JESD22-B102D	*Solder bath temperature : 255 ± 5°C *Immersion time : 5 ± 0.5 sec Solder : Sn3Ag0.5Cu for lead-free	At least 95% of a surface of each terminal electrode must be covered by fresh solder.
Leaching (Resistance to dissolution of metallization) IEC 60068-2-58	*Solder bath temperature : 260 ± 5°C *Leaching immersion time : 30 ± 0.5 sec Solder : SN63A	Loss of metallization on the edges of each electrode shall not exceed 25%.
Resistance to soldering heat JIS C 0050-5.4	*Preheating temperature : 120~150°C, 1 minute. *Solder temperature : 270±5°C *Immersion time : 10±1 sec Solder : Sn3Ag0.5Cu for lead-free Measurement to be made after keeping at room temperature for 24±2 hrs	No mechanical damage. Electrical specification shall satisfy the descriptions in electrical characteristics under the operational temperature range within -30 ~ 90°C. Loss of metallization on the edges of each electrode shall not exceed 25%.
Adhesive strength of termination JIS C 0051- 7.4.3	*Pressurizing force : 5N(≤ 0603) ; 10N(>0603) *Test time : 10±1 sec	No remarkable damage or removal of the termination.
Drop test JIS C 0044 Customer's specification.	*Height : 75 cm *Test Surface : Rigid surface of concrete or steel. *Times : 6 surfaces for each units ; 2 times for each side.	No mechanical damage. Electrical specification shall satisfy the descriptions in electrical characteristics under the operational temperature range within -30 ~ 90°C.
Vibration JIS C 0040	*Frequency : 10Hz~55Hz~10Hz(1min) *Total amplitude : 1.5mm *Test times : 6hrs.(Two hrs each in three mutually perpendicular directions)	No mechanical damage. Electrical specification shall satisfy the descriptions in electrical characteristics under the operational temperature range within -30 ~ 90°C.
Bending test JIS C 0051- 7.4.1	The middle part of substrate shall be pressurized by means of the pressurizing rod at a rate of about 1 mm/s per second until the deflection becomes 1mm and then pressure shall be maintained for 5±1 sec. Measurement to be made after keeping at room temperature for 24±2 hours	No mechanical damage. Electrical specification shall satisfy the descriptions in electrical characteristics under the operational temperature range within -30 ~ 90°C.
High temperature JIS C 0021	*Temperature : 90°C±2°C *Test duration : 1000+24/-0 hours Measurement to be made after keeping at room temperature for 24±2 hrs	No mechanical damage. Electrical specification shall satisfy the descriptions in electrical characteristics under the operational temperature range within -30 ~ 90°C.

**Approval Sheet**

Low temperature JIS C 0020	*Temperature : $-30^{\circ}\text{C}\pm 2^{\circ}\text{C}$ *Test duration : 1000+24/-0 hours Measurement to be made after keeping at room temperature for 24±2 hrs	No mechanical damage. Electrical specification shall satisfy the descriptions in electrical characteristics under the operational temperature range within $-30 \sim 90^{\circ}\text{C}$ .
Temperature cycle JIS C 0025	1. 30±3 minutes at $-30\pm 3^{\circ}\text{C}$ , 2. 10~15 minutes at room temperature, 3. 30±3 minutes at $+90\pm 3^{\circ}\text{C}$ , 4. 10~15 minutes at room temperature, Total 100 continuous cycles Measurement to be made after keeping at room temperature for 24±2 hrs	No mechanical damage. Electrical specification shall satisfy the descriptions in electrical characteristics under the operational temperature range within $-30 \sim 90^{\circ}\text{C}$ .
High temperature operation life (HTOL)	*Temperature : $90^{\circ}\text{C}$ *VDD = 4.8V *Time : 1000+24/-0 hrs. Measurement to be made after keeping at room temperature for 24±2 hrs	No mechanical damage. Electrical specification shall satisfy the descriptions in electrical characteristics under the operational temperature range within $-30 \sim 90^{\circ}\text{C}$ .

**Soldering Condition**

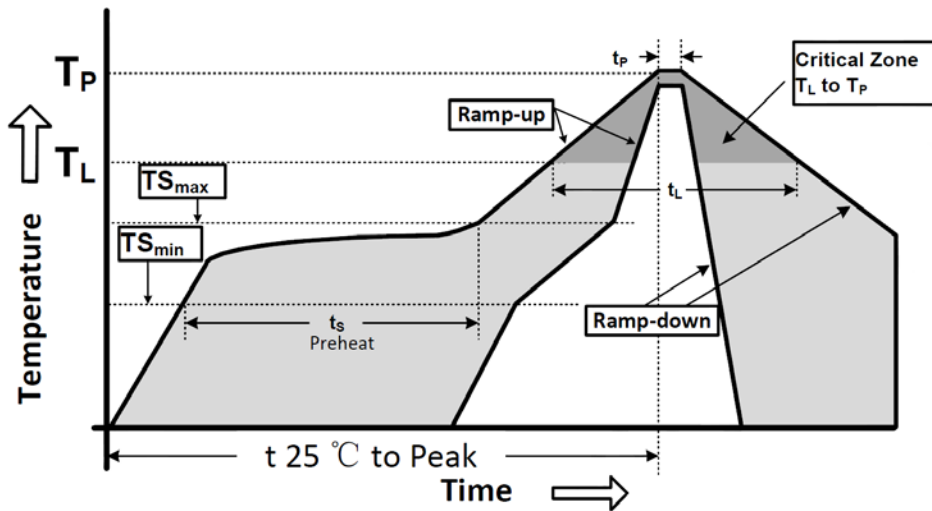

**Soldering Condition as Below**

Profile Parameter	Lead-Free Assembly, Convection, IR/Convection
Ramp-up rate ( $T_{S_{max}}$ to $T_p$ )	3°C/second max.
Preheat temperature ( $T_{S_{min}}$ to $T_{S_{max}}$ )	150°C to 200°C
Preheat time ( $t_s$ )	60 - 180 seconds
Time above $T_L$ , 217°C ( $t_L$ )	60 - 150 seconds
Peak temperature ( $T_p$ )	260°C
Time within 5°C of peak temperature ( $t_p$ )	20 - 40 seconds
Ramp-down rate	6°C/second max.
Time 25°C to peak temperature	8 minutes max.

**Approval Sheet**

**Ordering code**

<b>RF</b>	<b>ASW</b>	<b>K</b>	<b>H4414A</b>	<b>T</b>
<b>RF module</b> RF: Walsin RF Switch Device	<b>Module type</b> ASW: Antenna Switch	<b>Application</b> K: SP4T	<b>Design Code</b>	<b>Packing</b> T: Taping

Minimum Ordering Quantity: 3000 pcs per reel.

**Packaging**

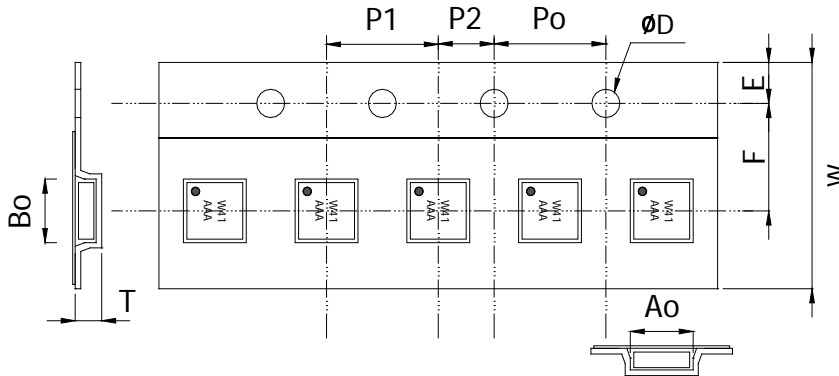

Plastic Tape specifications (unit :mm)

Index	Ao	Bo	øD	T	W
Dimension (mm)	2.30 ± 0.10	2.30 ± 0.10	1.50 ± 0.05	0.70 ± 0.10	8.0 ± 0.30
Index	E	F	Po	P1	P2
Dimension (mm)	1.75 ± 0.10	3.50 ± 0.05	4.00 ± 0.20	4.00 ± 0.10	2.00 ± 0.05

**Reel dimensions**

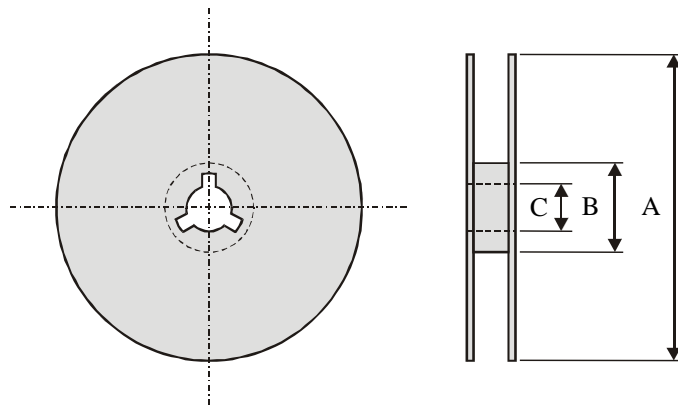

Index	A	B	C
Dimension (mm)	Φ178.0	Φ54.0	Φ13.2

Taping Quantity : 3000 pieces per 7" reel



## Approval Sheet

### Caution of handling

#### Limitation of Applications

Please contact us before using our products for the applications listed below which require especially high reliability for the prevention of defects, which might directly cause damage to the third party's life, body or property.

- (1) Aircraft equipment
- (2) Aerospace equipment
- (3) Undersea equipment
- (4) Medical equipment
- (5) Disaster prevention / crime prevention equipment
- (6) Traffic signal equipment
- (7) Transportation equipment (vehicles, trains, ships, etc.)
- (8) Applications of similar complexity and /or reliability requirements to the applications listed in the above.

### Storage condition

- (1) Products should be used in 6 months from the day of WALSIN outgoing inspection, which can be confirmed.
- (2) Storage environment condition.
  - Products should be storage in the warehouse on the following conditions.
  - Temperature : -10 to +40°C
  - Humidity : 30 to 70% relative humidity
  - Don't keep products in corrosive gases such as sulfur. Chlorine gas or acid or it may cause oxidization of electrode, resulting in poor solderability.
  - Products should be storage on the palette for the prevention of the influence from humidity, dust and son on.
  - Products should be storage in the warehouse without heat shock, vibration, direct sunlight and so on.
  - Products should be storage under the airtight packaged condition.