

High Frequency Power Supply Controller

GENERAL DESCRIPTION

The ML4825 High Frequency PWM Controller is an IC controller optimized for use in Switch Mode Power Supply designs running at frequencies to 1MHz. Propagation delays are minimal through the comparators and logic for reliable high frequency operation while slew rate and bandwidth are maximized on the error amplifier. This controller is designed to work in either voltage or current mode and provides for input voltage feed forward.

A 1V threshold current limit comparator provides cycle-by-cycle current limit while exceeding a 1.4V threshold initiates a soft-start cycle. The soft start pin doubles as a maximum duty cycle clamp. An under-voltage lockout circuit with 800mV of hysteresis assures low startup current and drives the outputs low.

This controller is similar in architecture and performance to the UC1825 controller, however the ML4825 includes many features not found on the 1825. These features are set in *Italics*.

FEATURES

- Practical operation at switching frequencies to 1.0MHz
- High current (2A peak) dual totem pole outputs
- Wide bandwidth error amplifier
- Fully latched logic with double pulse suppression
- Pulse-by-pulse current limiting
- Soft start and maximum duty cycle control
- Under voltage lockout with hysteresis
- Precision trimmed 5.1V bandgap reference
- Pin compatible improved replacement for UC1825
- *Fast shut down path from current limit to outputs*
- *Outputs preset to known condition after under voltage lockout*
- *Soft start latch ensures full soft start cycle*
- *Outputs pull low for undervoltage lockout*

BLOCK DIAGRAM (Pin configuration shown for 16-pin version)

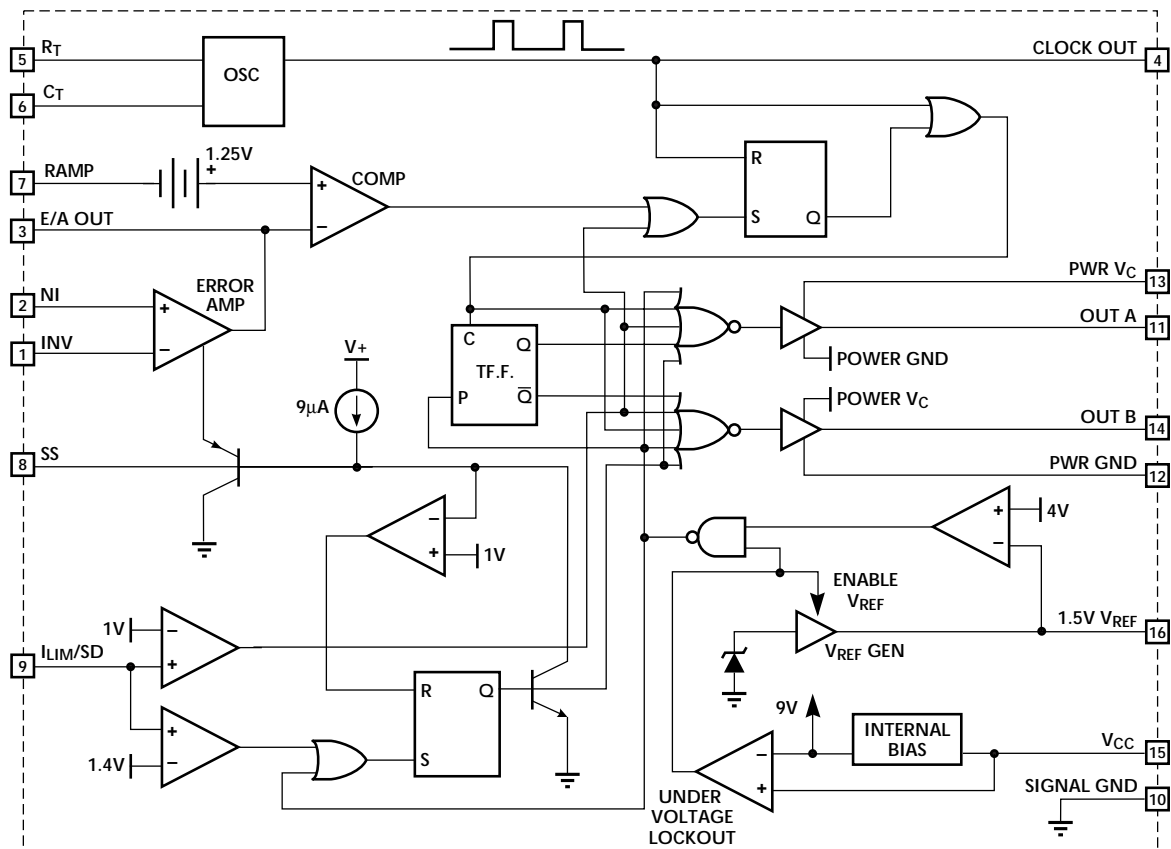

PIN CONFIGURATION

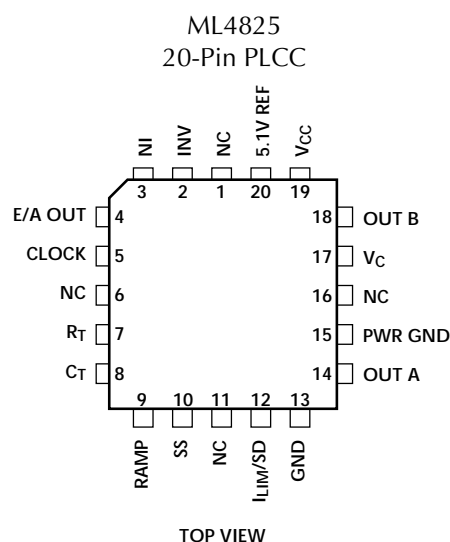
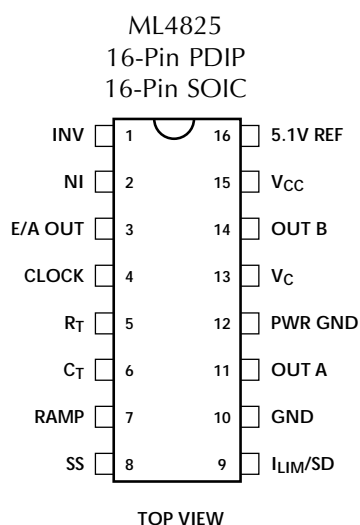

PIN DESCRIPTION (Pin number in parentheses is for PLCC version)

PIN	NAME	FUNCTION	PIN	NAME	FUNCTION
1 (2)	INV	Inverting input to error amp.	9 (12)	I_{LIM}/SD	Current limit sense pin. Normally connected to current sense resistor.
2 (3)	NI	Non-inverting input to error amp.	10 (13)	GND	Analog signal ground
3 (4)	E/A OUT	Output of error amplifier and input to main comparator	11 (14)	OUT A	High current totem pole output. This output is the first one energized after power on reset
4 (5)	CLOCK	Oscillator output	12 (15)	PWR GND	Return for the high current totem pole outputs
5 (7)	R_T	Timing resistor for oscillator—sets charging current for oscillator timing capacitor (pin 6)	13 (17)	V_C	Positive supply for the high current totem pole output
6 (8)	C_T	Timing capacitor for oscillator	14 (18)	OUT B	High current totem pole output
7 (9)	RAMP	Non-inverting input to main comparator. Connected to C_T for voltage mode operation or to current sense resistor for current mode	15 (19)	V_{CC}	Positive supply for the IC
8 (10)	SS	Normally connected to soft start capacitor	16 (20)	5.1V REF	Buffered output for the 5.1V voltage reference

ABSOLUTE MAXIMUM RATINGS

Absolute maximum ratings are those values beyond which the device could be permanently damaged. Absolute maximum ratings are stress ratings only and functional device operation is not implied.

Supply Voltage (V_C , V_{CC})	30V
Output Current, Source or Sink (OUT A, OUT B)	
DC	0.5A
Pulse (0.5 μ s)	2.0A
Analog Inputs	
(INV, NI, RAMP)	GND –0.3V to 7V
(SS, I _{LIM})	GND –0.3V to 6V
CLOCK Output Current	–5mA
E/A OUT Output Current	5mA
Soft Start Sink Current	20mA
R_T Charging Current	–5mA

Junction Temperature	
ML4825IX, ML4825CX	150°C
Storage Temperature Range	–65°C to 150°C
Lead Temperature (soldering 10 sec.)	260°C
Thermal Resistance (θ_{JA})	
Plastic DIP or SOIC	65°C/W
Plastic Chip Carrier (PCC)	60°C/W

OPERATING CONDITIONS

Temperature Range	
ML4825CX	0°C to 70°C
ML4825IX	–40°C to 85°C

ELECTRICAL CHARACTERISTICS

Unless otherwise specified, $R_T = 3.65k\Omega$, $C_T = 1000pF$, $T_A =$ Operating Temperature Range, $V_{CC} = 15V$ (Note 1).

PARAMETER	CONDITIONS	MIN	TYP	MAX	UNITS	
OSCILLATOR						
Initial Accuracy	$T_J = 25^\circ C$	360	400	440	kHz	
Voltage Stability	$10V < V_{CC} < 30V$, $T_A = 25^\circ C$	–2	0.2	2	%	
Temperature Stability				5	%	
Total Variation	Line, temperature	340		460	kHz	
Clock Out High		3.9	4.5		V	
Clock Out Low			2.3	2.9	V	
Ramp Peak		2.6	2.8	3.0	V	
Ramp Valley		0.7	1.0	1.25	V	
Ramp Valley to Peak		1.6	1.8	2.0	V	
REFERENCE						
Output Voltage	$T_J = 25^\circ C$, $I_O = 1mA$	C suffix	5.00	5.10	5.20	V
		I suffix	5.00	5.10	5.20	V
Line Regulation	$10V < V_{CC} < 30V$	–20	2	20	mV	
Load Regulation	$1mA < I_O < 10mA$	–20	5	20	mV	
Temperature Stability	$-55^\circ C < T_J < 150^\circ C$		0.2	0.4	%	
Total Variation	Line, load, temperature	C suffix	4.95		5.25	V
		I suffix	4.95		5.25	V
Output Noise Voltage	10Hz to 10kHz		50		μV	
Long Term Stability	$T_J = 125^\circ C$, 1000 hours		5	25	mV	
Short Circuit Current	$V_{REF} = 0V$	–15	–50	–100	mA	
ERROR AMPLIFIER						
Input Offset Voltage	C suffix	–15		15	mV	
	I suffix	–15		15	mV	
Input Bias Current			0.6	3	μA	
Input Offset Current			0.1	1	μA	
Open Loop Gain	$1 < V_O < 4V$	60	96		dB	

ELECTRICAL CHARACTERISTICS (Continued)

PARAMETER	CONDITIONS		MIN	TYP	MAX	UNITS
ERROR AMPLIFIER (Continued)						
CMRR	$1.5V < V_{CM} < 5.5V$	C suffix	75	95		dB
		I suffix	75	95		dB
PSRR	$10V < V_{CC} < 30V$	C suffix	80	110		dB
		I suffix	80	110		dB
Output Sink Current	$V_{EA\ OUT\ A} = 1.0V$		1	2.5		mA
Output Source Current	$V_{EA\ OUT\ A} = 4.0V$		-0.5	-1.3		mA
Output High Voltage	$I_{EA\ OUT\ A} = -0.5mA$		4.0	4.7	5.0	V
Output Low Voltage	$I_{EA\ OUT\ A} = 1mA$		0	0.5	1.0	V
Unity Gain Bandwidth			3	5.5		MHz
Slew Rate			6	12		V/ μ s
PWM COMPARATOR						
Ramp Bias Current	$V_{RAMP} = 0V, T_A > 0^\circ C$	C suffix		-1	-5	μ A
		I suffix			-5	μ A
Duty Cycle Range		C suffix	85		100	%
		I suffix	80		100	%
E/A OUT Zero DC Threshold	$V_{RAMP} = 0V$		1.1	1.25	1.7	V
Delay to Output				50	80	nS
SOFT START						
Charge Current	$SS = 0.5V$		-3	-9	-20	μ A
Discharge Current	$SS = 1V$		1			mA
CURRENT LIMIT/SHUTDOWN						
I_{LIM} Bias Current	$0V < V_{I(LIM)} < 0.5V$	C suffix	-10		10	μ A
		I suffix	-10		10	μ A
Current Limit Threshold			0.9	1	1.1	V
Shutdown Threshold	$T_A > 0^\circ C$		1.25	1.4	1.55	V
	$T_A < 0^\circ C$		1.25	1.4	1.60	V
Delay to Output				40	70	ns
OUTPUT						
Output Low Level	$I_{OUT} = 20mA$			0.25	0.4	V
	$I_{OUT} = 200mA$			1.2	2.2	V
Output High Level	$I_{OUT} = -20mA$		13.0	13.5		V
	$I_{OUT} = -200mA$		12.0	13.0		V
Collector Leakage	$V_C = 30V$			100	500	μ A
Rise/Fall Time	$C_L = 1000pF$			30	60	ns
UNDERVOLTAGE LOCKOUT						
Start Threshold			8.8	9.2	9.6	V
UVLO Hysteresis			0.3	0.8	1.2	V
SUPPLY						
Start Up Current	$V_{CC} = 8V$	C suffix	0.1	1.1	2.5	mA
		I suffix	0.1		3.5	mA
I_{CC}	$V_{INV}, V_{RAMP}, V_{I(LIM)/SD} = 0V,$ $V_{NI} = 1V, T_A = 25^\circ C$		10	26	33	mA

Note 1: Limits are guaranteed by 100% testing, sampling, or correlation with worst-case test conditions.

FUNCTIONAL DESCRIPTION

OSCILLATOR

The ML4825 oscillator charges the external capacitor (C_T) with a current (I_{SET}) equal to $3/R_{SET}$. When the capacitor voltage reaches the upper threshold (Ramp Peak), the comparator changes state and the capacitor discharges to the lower threshold (Ramp Valley) through Q1. While the capacitor is discharging, Q2 provides a high pulse.

The oscillator period can be described by the following relationship:

$$t_{OSC} = t_{RAMP} + t_{DEADTIME}$$

where:

$$t_{RAMP} = \frac{C \text{ (Ramp Valley to Peak)}}{I_{SET}}$$

and:

$$t_{DEADTIME} = \frac{C \text{ (Ramp Valley to Peak)}}{I_{Q1}}$$

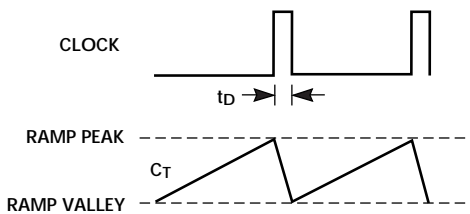
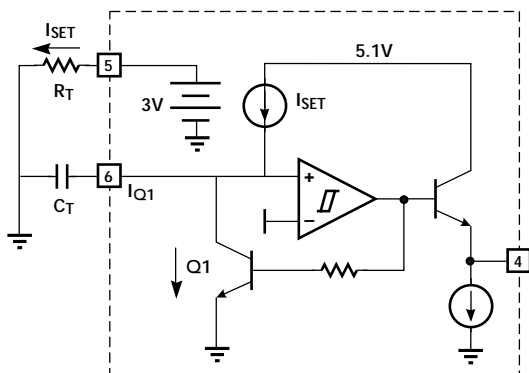

Figure 1. Oscillator Block Diagram

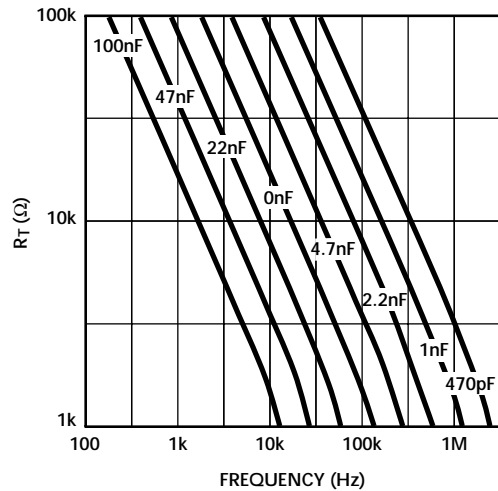

Figure 2. Oscillator Timing Resistance vs Frequency

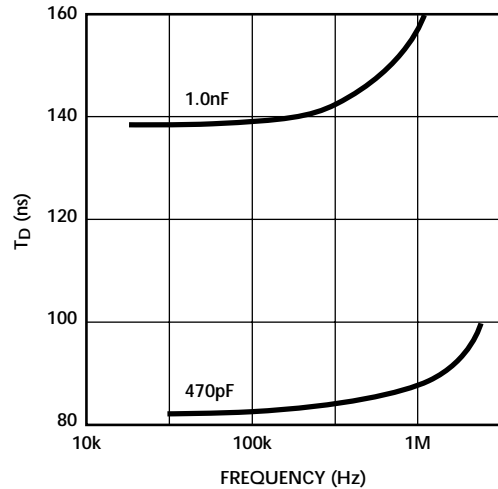

Figure 3. Oscillator Deadtime vs Frequency

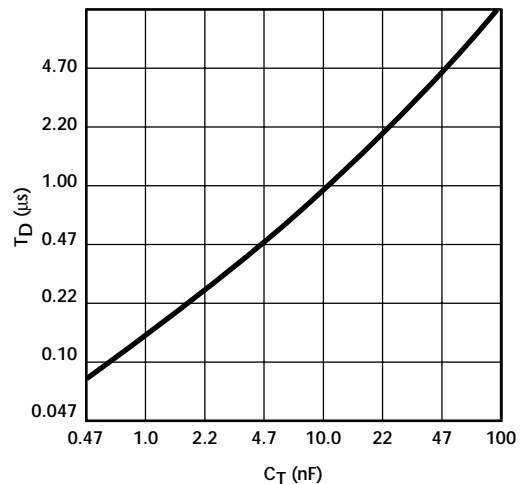

Figure 4. Oscillator Deadtime vs C_T ($3k\Omega \leq R_T \leq 100k\Omega$)

ERROR AMPLIFIER

The ML4825 error amplifier is a 5.5MHz bandwidth 12V/ μ s slew rate op-amp with provision for limiting the positive output voltage swing (Output Inhibit line) for ease in implementing the soft start function.

OUTPUT DRIVER STAGE

The ML4825 Output Driver is a 2A peak output high speed totem pole circuit designed to quickly switch the gates of capacitive loads, such as power MOSFET transistors.

SOFT START AND CURRENT LIMIT

The ML4825 employs two current limits. When the voltage at I_{LIM}/SD exceeds 1V, the outputs are immediately shut off and the cycle is terminated for the remainder of the oscillator period by resetting the RS flip flop.

If the output current is rising quickly such that the voltage on I_{LIM}/SD reaches 1.4V before the outputs have turned off, a soft start cycle is initiated. The soft start capacitor is discharged and outputs are held "off" until the voltage at SS reaches 1V, ensuring a complete soft start cycle. The duty cycle on start up is limited by limiting the output voltage of the error amplifier voltage to the voltage at SS.

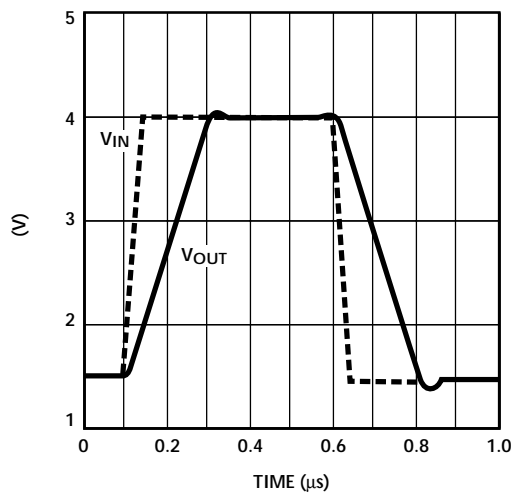

Figure 5. Unity Gain Slew Rate

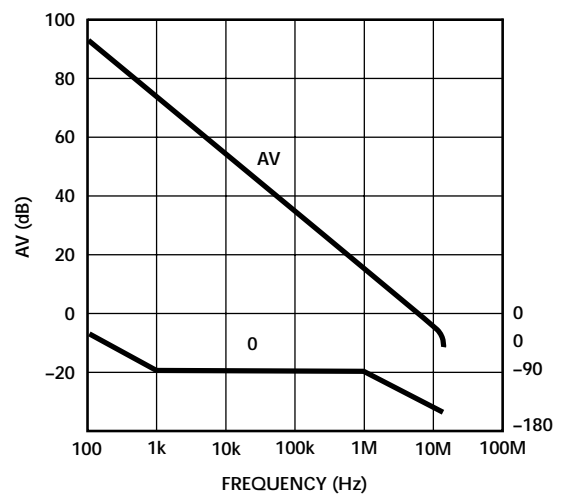

Figure 6. Open Loop Frequency Response

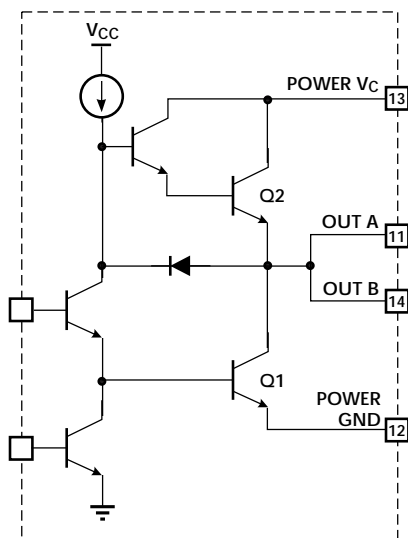

Figure 7. Simplified Schematic

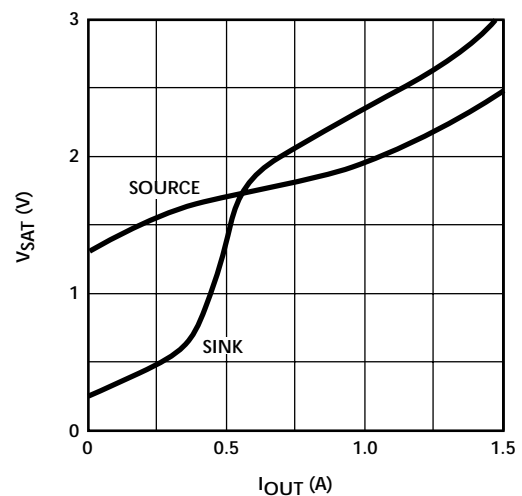

Figure 8. Saturation Curves

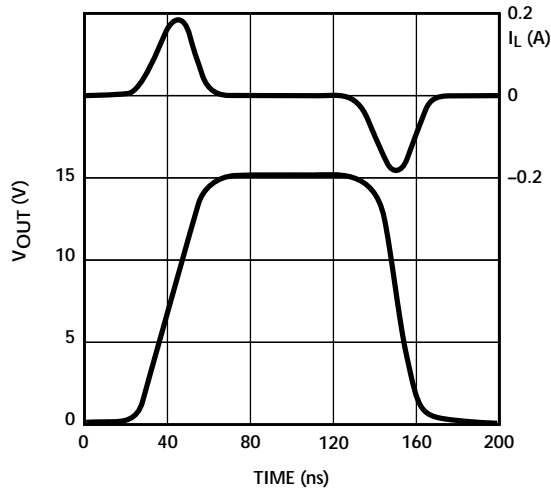

Figure 9. Rise/Fall Time ($C_L = 1000\text{pF}$)

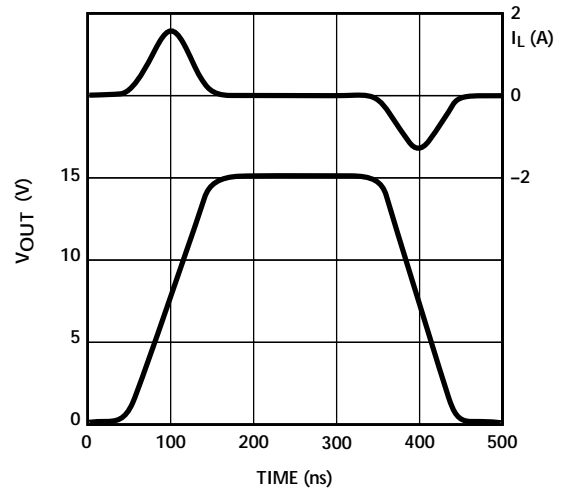

Figure 10. Rise/Fall Time ($C_L = 10,000\text{pF}$)

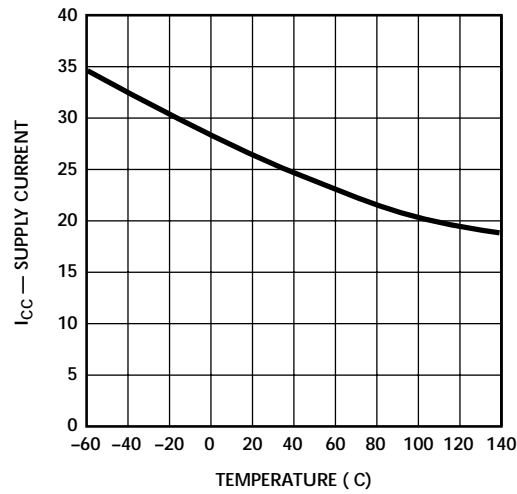
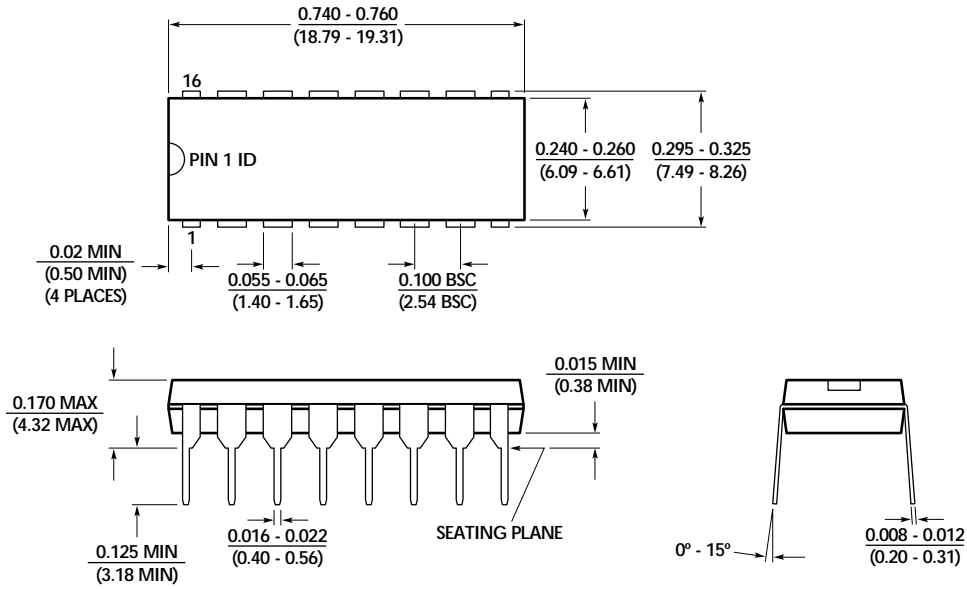

Figure 11. Supply Current vs. Temperature

PHYSICAL DIMENSIONS inches (millimeters)

Package: P16
16-Pin PDIP



Package: S16W
16-Pin Wide SOIC

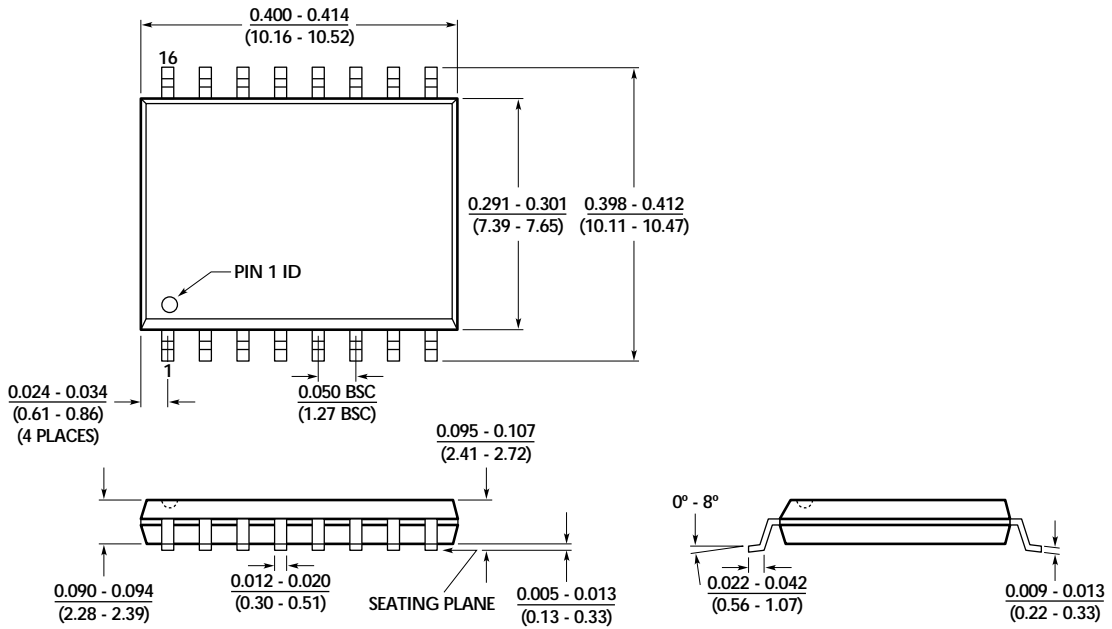

PHYSICAL DIMENSIONS inches (millimeters) (Continued)

Package: Q20
20-Pin PLCC

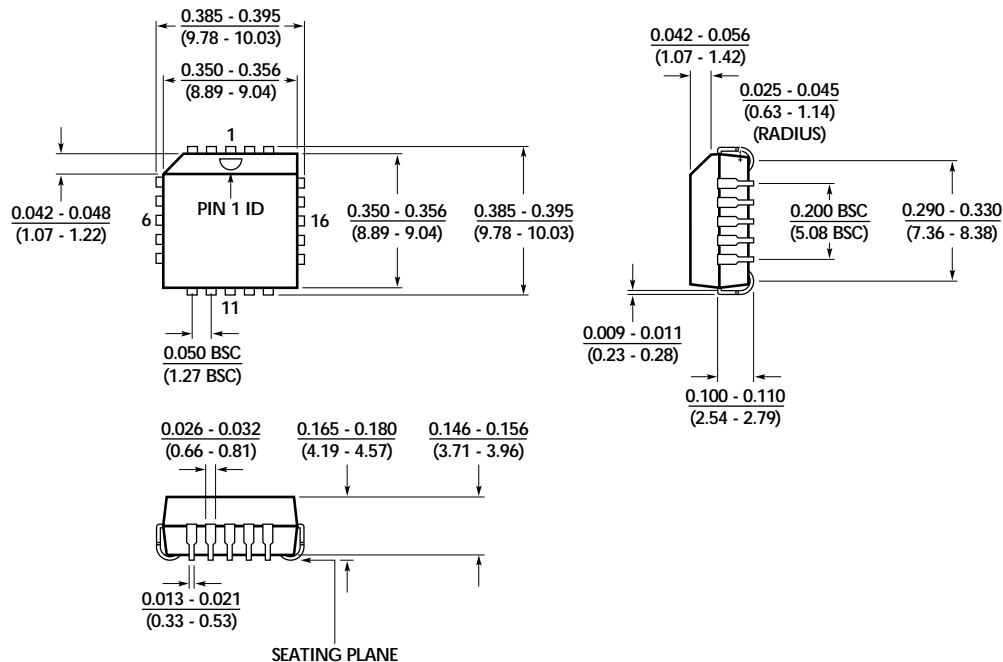

ORDERING INFORMATION

PART NUMBER	TEMPERATURE RANGE	PACKAGE
ML4825CP	0°C to 70°C	16-Pin PDIP (P16)
ML4825CS	0°C to 70°C	16-Pin Wide SOIC (S16W)
ML4825CQ	0°C to 70°C	20-Pin PLCC (Q20)
ML4825IP	-40°C to 85°C	16-Pin PDIP (P16)
ML4825IS	-40°C to 85°C	16-Pin Wide SOIC (S16W)
ML4825IQ	-40°C to 85°C	20-Pin PLCC (Q20)

DISCLAIMER

FAIRCHILD SEMICONDUCTOR RESERVES THE RIGHT TO MAKE CHANGES WITHOUT FURTHER NOTICE TO ANY PRODUCTS HEREIN TO IMPROVE RELIABILITY, FUNCTION OR DESIGN. FAIRCHILD DOES NOT ASSUME ANY LIABILITY ARISING OUT OF THE APPLICATION OR USE OF ANY PRODUCT OR CIRCUIT DESCRIBED HEREIN; NEITHER DOES IT CONVEY ANY LICENSE UNDER ITS PATENT RIGHTS, NOR THE RIGHTS OF OTHERS.

LIFE SUPPORT POLICY

FAIRCHILD'S PRODUCTS ARE NOT AUTHORIZED FOR USE AS CRITICAL COMPONENTS IN LIFE SUPPORT DEVICES OR SYSTEMS WITHOUT THE EXPRESS WRITTEN APPROVAL OF THE PRESIDENT OF FAIRCHILD SEMICONDUCTOR CORPORATION. As used herein:

1. Life support devices or systems are devices or systems which, (a) are intended for surgical implant into the body, or (b) support or sustain life, and (c) whose failure to perform when properly used in accordance with instructions for use provided in the labeling, can be reasonably expected to result in a significant injury of the user.
2. A critical component in any component of a life support device or system whose failure to perform can be reasonably expected to cause the failure of the life support device or system, or to affect its safety or effectiveness.