

## CC6921B

### High Performance, Hall Effect-Based Current Sensor IC with a Low-Resistance Conductor 5A/10A/20A/25A/30A/40A/50A/65A/75A/100A series

#### GENERAL DESCRIPTION

The CC6921B device is a high-performance current sensor based on Hall Effect. The device provides precise and economical solutions for AC or DC current sensing in industrial, commercial and communication equipment.

The CC6921B device consists of a precise, low-offset, linear Hall circuit with a copper conduction path located near the surface of the die. When current flows through the copper conduction path, a magnetic field generates. Meanwhile the Hall circuit converts this magnetic signal to output voltage signal. Internal copper conductor's resistance is typical 0.45mΩ, which provides much less power loss than the universal resistor sampling method. Otherwise, its internal inherent insulation provides 1000V<sub>RMS</sub> basic working isolation voltage and 3750V (AC) insulation withstand voltage between the input current path and the secondary circuit.

The Hall circuit based on BiCOMS process integrates a high sensitivity Hall element, oscillator, Hall signal pre-amplifier, CrossChip® patented temperature compensation circuit, dynamic offset cancellation circuit, sensitivity trimming circuit and output amplifier.

Zero current output voltage is 50%VCC. When power supply voltage is 3.3V, the linear output voltage range is 0.33~2.97V, the linearity can reach 0.1%.

CC6921B is available in SOP16W package. It's operating ambient temperature range is -40~125°C. Comply with RoHS requirements.

#### FEATURES

- ◆ Zero current output voltage is 50%VCC
- ◆ Current sensing range available:  
5A/10A/20A/25A/30A/40A/50A/65A/75A/100A
- ◆ 1.2MHz chopper frequency, high bandwidth, low noise, single ended analog output
- ◆ High isolation and withstand voltage (3750V(AC) isolation voltage between pins 1-8 and 9-16)
- ◆ Less power loss, internal conductor's resistance is 0.45mΩ
- ◆ High bandwidth, up to 250KHz, 1.2μs output rise time in response to step input current
- ◆ Total output error  $\pm 1\%$  at  $T_a=25^\circ\text{C}$  and  $\pm 3\%$  at  $T_a=-40\sim 125^\circ\text{C}$
- ◆ CrossChip® patented temperature compensation
- ◆ Outputs desensitized to mechanical stress
- ◆ Differential Hall structure, strong resistance to external magnetic interference
- ◆ ESD (HBM) 4000V
- ◆ Operating ambient temperature: -40~125°C

#### APPLICATIONS

- ◆ Motor controller
- ◆ Load detection and management
- ◆ Switch-mode power supplies
- ◆ Over-current fault protection



Type Approved  
Safety  
Regular Production  
Surveillance  
[www.tuv.com](http://www.tuv.com)  
ID 2000000000

Certificate Number:  
LVD: AN 50544139 001  
TUV MARK: R 50531533



Certificate Number  
E526186

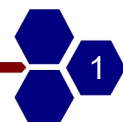

**FUNCTION BLOCK DIAGRAM**

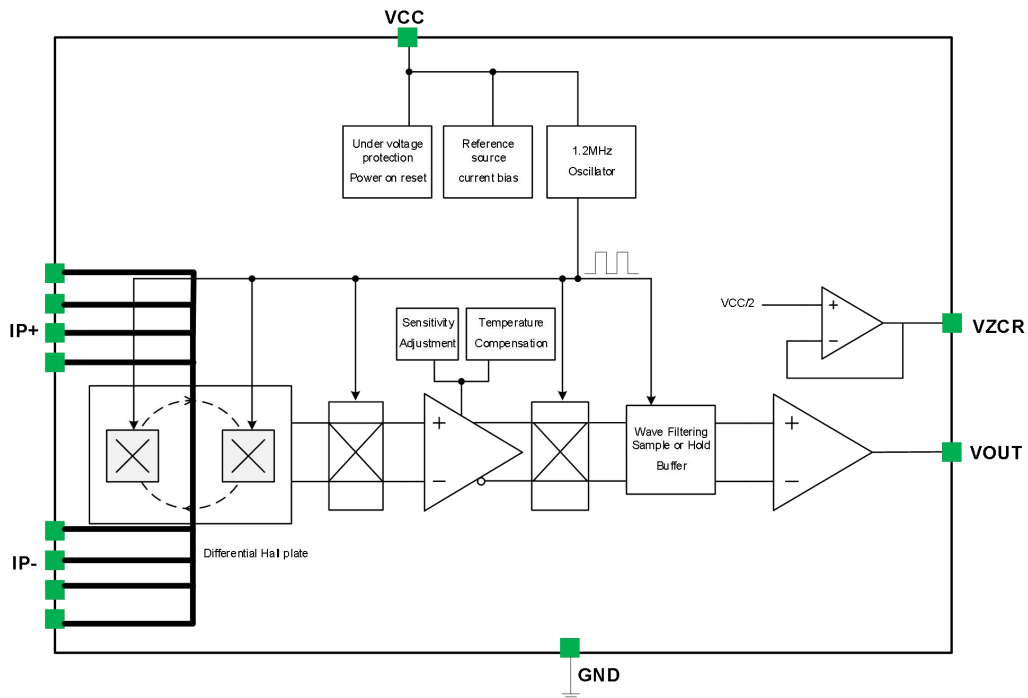

**ORDERING INFORMATION**

Part No.	SENS. (mV/A)	Package	Packing Form
CC6921BSO-5A	264	SOP16W	tape reel, 1000 pcs/reel
CC6921BSO-10A	132	SOP16W	tape reel, 1000 pcs/reel
CC6921BSO-20A	66	SOP16W	tape reel, 1000 pcs/reel
CC6921BSO-25A	52.8	SOP16W	tape reel, 1000 pcs/reel
CC6921BSO-30A	44	SOP16W	tape reel, 1000 pcs/reel
CC6921BSO-40A	33	SOP16W	tape reel, 1000 pcs/reel
CC6921BSO-50A	26.4	SOP16W	tape reel, 1000 pcs/reel
CC6921BSO-65A	20.3	SOP16W	tape reel, 1000 pcs/reel
CC6921BSO-75A	17.6	SOP16W	tape reel, 1000 pcs/reel
CC6921BSO-100A	13.2	SOP16W	tape reel, 1000 pcs/reel
CC6921SO-YYA (Note 1)	-	SOP16W	tape reel, 1000 pcs/reel

**Note 1:** When YYA is within the range of 100A, customers can customize the range according to their needs.

**PINOUT DIAGRAM**

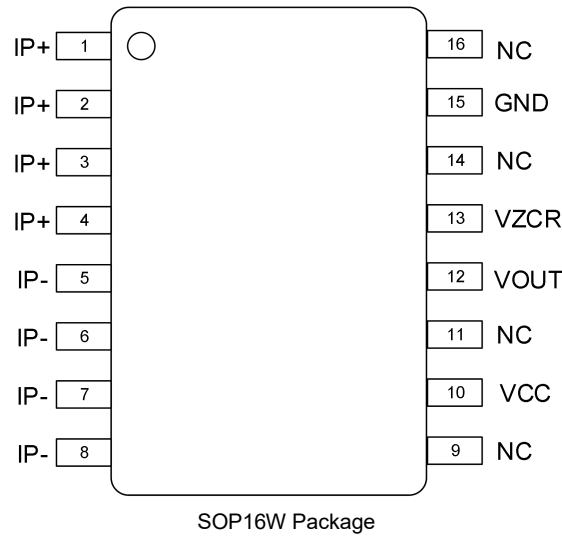

Name	Number	Description	Name	Number	Description
IP+	1	Current Sampled +	NC	9	NC
IP+	2	Current Sampled +	VCC	10	Power Supply
IP+	3	Current Sampled +	NC	11	NC
IP+	4	Current Sampled +	VOUT	12	Analog Voltage Output
IP-	5	Current Sampled -	VZCR	13	Zero Current Reference
IP-	6	Current Sampled -	NC	14	NC
IP-	7	Current Sampled -	GND	15	Ground
IP-	8	Current Sampled -	NC	16	NC

**ABSOLUTE MAXIMUM RATINGS**

Parameter	Symbol	Value	Unit
Power Supply	$V_{CC}$	7	V
Output Voltage	$V_{OUT}$	-0.3~VCC+0.3	V
Output Source Current	$I_{OUT(SOURCE)}$	6	mA
Output Sink Current	$I_{OUT(SINK)}$	30	mA
Input current peak current (3 s)	$I_{PEAK}$	100	A
Input current continuous current	$I_{CON}$	60	A
Isolation Voltage	$V_{ISO}$	3750	VAC
Operating Ambient Temperature	$T_a$	-40~125	°C
Junction Temperature	$T_J$	165	°C
Storage Temperature	$T_s$	-55~150	°C
Magnetic Flux Density	B	Not Limited	mT
Electrostatic Discharge Voltage (HBM)	ESD(HBM)	4000	V

**Note:** Stresses beyond those listed under *Absolute Maximum Ratings* may cause permanent damage to the device. Exposure to absolute-maximum-rated conditions for extended periods may affect device reliability.

## ISOLATION CHARACTERISTICS

Parameter	Symbol	Test Conditions	Value	Unit
Withstand isolation voltage	V <sub>ISO</sub>	Test method: 50 / 60Hz, 1min	3750	V <sub>RMS</sub>
	V <sub>TEST</sub>	t = 1s (100% production)	4500	V <sub>RMS</sub>
Working Voltage for Basic Insulation	V <sub>WVBI</sub>	Basic insulation	1414	V <sub>PK</sub> or VDC
		UL standard 62368-1:2014	1000	V <sub>RMS</sub>
Clearance	D <sub>cl</sub>	minimum distance through air from IP leads to signal leads	7.8	mm
Maximum surge isolation voltage (Note 1)	V <sub>IOSM</sub>	Tested 1.2us (rise) / 50us (width) One time	11k	V <sub>PK</sub>
Surge Current (Note 2)	I <sub>SURGE</sub>	Tested in compliance to IEC 61000-4-5 8μs (rise) / 20μs (width)	16	kA

**Note1:** Testing is carried out in air to determine the intrinsic surge immunity of the isolation barrier.

**Note2:** Certification pending.

## RECOMMENDED OPERATING CONDITIONS

Parameter	Symbol	Min.	Max.	Unit
Input voltage (Note 1)	VIN+, VIN- (Note 1)	-1414	1414	V <sub>PK</sub>
Input current (DC / AC RMS) (Note 2)	I <sub>P</sub>	-50	50	A
Power Supply	V <sub>CC</sub>	3.0	3.6	V
Operation Temperature	T <sub>A</sub>	-40	125	°C

**Note 1:** Vin +, VIN – refers to the voltage of current input pins IP + and IP -, relative to pin 15 (GND), Basic Insulation.

**Note 2:** Decrease due to higher ambient temperature.

## ELECTRICAL PARAMETERS (T<sub>a</sub>=25°C and V<sub>CC</sub>=3.3V, unless otherwise specified)

Parameter	Symbol	Conditions	Min.	Typ.	Max.	Unit
Power Supply	V <sub>CC</sub>	-	3.0	3.3	3.6	V
Supply Current	I <sub>CC</sub>	OUT pin floated	-	20	25	mA
Internal benchmark	V <sub>ZCR</sub>		-	1.65	-	V
Zero Current Output Voltage	V <sub>OUT(Q)</sub>	IP=0	-	1.65	-	V
Output Capacitance Load	C <sub>L</sub>		-	-	1	nF
Output Resistive Load	R <sub>L</sub>		1.5	-	-	kΩ
Resistance of Primary Conductor	R <sub>P</sub>		-	0.45	-	mΩ
Propagation Time	t <sub>D</sub>			1	2	us
Rise Time	t <sub>r</sub>		-	1	2.2	us
Common Mode Rejection Ratio	CMRR		38	-	-	dB
Bandwidth	BW	-3dB	250	-	-	kHz
Reference Output Source Current	I <sub>ZCR(SOURCE)</sub>		-	-	400	uA
Reference Output Sink Current	I <sub>ZCR(SINK)</sub>		-	-	2000	uA

Continued:						
Nonlinearity	$L_{INERR}$		-	0.2	0.5	%
Symmetry	$Sym_{ERR}$		-	0.8	1.5	%
Power-on Time	$T_{POR}$	Output rising from 0 to 90% of steady-state	-	10	-	us

## 5A PERFORMANCE CHARACTERISTICS

Parameter	Symbol	Conditions	Min.	Typ.	Max.	Unit
Current Accuracy Range	$I_P$	-	-5	-	5	A
Sensitivity	Sens	full range of $I_P$	256.1	264	271.9	mV/A
Zero Current Differential Output Error	$V_{OE}$		-30		30	mV
Noise	$V_{NOISE(RMS)}$		-	43	-	mV
Zero Current Output Slope	$\Delta V_{OUT(Q)}$		-	0.22	-	mV/°C
Sensitivity Slope	$\Delta_{SENS}$		-	0.042	-	mV/A/°C
Total Output Error	$E_{TOT}$		-2.0	-	2.0	%

## 10A PERFORMANCE CHARACTERISTICS

Parameter	Symbol	Conditions	Min.	Typ.	Max.	Unit
Current Accuracy Range	$I_P$	-	-10	-	10	A
Sensitivity	Sens	full range of $I_P$	128	132	136	mV/A
Zero Current Differential Output Error	$V_{OE}$		-29		29	mV
Noise	$V_{NOISE(RMS)}$		-	22	-	mV
Zero Current Output Slope	$\Delta V_{OUT(Q)}$		-	0.22	-	mV/°C
Sensitivity Slope	$\Delta_{SENS}$		-	0.021	-	mV/A/°C
Total Output Error	$E_{TOT}$		-2.0	-	2.0	%

## 20A PERFORMANCE CHARACTERISTICS

Parameter	Symbol	Conditions	Min.	Typ.	Max.	Unit
Current Accuracy Range	$I_P$	-	-20	-	20	A
Sensitivity	Sens	full range of $I_P$	64	66	68	mV/A
Zero Current Differential Output Error	$V_{OE}$		-27		27	mV
Noise	$V_{NOISE(RMS)}$		-	11	-	mV
Zero Current Output Slope	$\Delta V_{OUT(Q)}$		-	0.22	-	mV/°C
Sensitivity Slope	$\Delta_{SENS}$		-	0.011	-	mV/A/°C
Total Output Error	$E_{TOT}$		-2.0	-	2.0	%

## 25A PERFORMANCE CHARACTERISTICS

Parameter	Symbol	Conditions	Min.	Typ.	Max.	Unit
Current Accuracy Range	$I_P$	-	-25	-	25	A
Sensitivity	Sens	full range of $I_P$	51.2	52.8	54.4	mV/A
Zero Current Differential Output Error	$V_{OE}$		-25		25	mV
Noise	$V_{NOISE(RMS)}$		-	10	-	mV
Zero Current Output Slope	$\Delta V_{OUT(Q)}$		-	0.22	-	mV/°C
Sensitivity Slope	$\Delta SENS$		-	0.008	-	mV/A/°C
Total Output Error	$E_{TOT}$		-2.0	-	2.0	%

## 30A PERFORMANCE CHARACTERISTICS

Parameter	Symbol	Conditions	Min.	Typ.	Max.	Unit
Current Accuracy Range	$I_P$	-	-30	-	30	A
Sensitivity	Sens	full range of $I_P$	42.7	44	45.3	mV/A
Zero Current Differential Output Error	$V_{OE}$		-20		20	mV
Noise	$V_{NOISE(RMS)}$		-	10	-	mV
Zero Current Output Slope	$\Delta V_{OUT(Q)}$		-	0.22	-	mV/°C
Sensitivity Slope	$\Delta SENS$		-	0.007	-	mV/A/°C
Total Output Error	$E_{TOT}$		-2.0	-	2.0	%

## 40A PERFORMANCE CHARACTERISTICS

Parameter	Symbol	Conditions	Min.	Typ.	Max.	Unit
Current Accuracy Range	$I_P$	-	-40	-	40	A
Sensitivity	Sens	full range of $I_P$	32	33	34	mV/A
Zero Current Differential Output Error	$V_{OE}$		-17		17	mV
Noise	$V_{NOISE(RMS)}$		-	10	-	mV
Zero Current Output Slope	$\Delta V_{OUT(Q)}$		-	0.22	-	mV/°C
Sensitivity Slope	$\Delta SENS$		-	0.005	-	mV/A/°C
Total Output Error	$E_{TOT}$		-2.0	-	2.0	%

## 50A PERFORMANCE CHARACTERISTICS

Parameter	Symbol	Conditions	Min.	Typ.	Max.	Unit
Current Accuracy Range	$I_P$	-	-50	-	50	A
Sensitivity	Sens	full range of $I_P$	25.6	26.4	27.2	mV/A
Zero Current Differential Output Error	$V_{OE}$		-14		14	mV
Noise	$V_{NOISE(RMS)}$		-	10	-	mV
Zero Current Output Slope	$\Delta V_{OUT(Q)}$		-	0.22	-	mV/°C
Sensitivity Slope	$\Delta SENS$		-	0.004	-	mV/A/°C
Total Output Error	$E_{TOT}$		-2.0	-	2.0	%

## 65A PERFORMANCE CHARACTERISTICS

Parameter	Symbol	Conditions	Min.	Typ.	Max.	Unit
Current Accuracy Range	$I_P$	-	-65	-	65	A
Sensitivity	Sens	full range of $I_P$	19.7	20.3	20.9	mV/A
Zero Current Differential Output Error	$V_{OE}$		-10		10	mV
Noise	$V_{NOISE(RMS)}$		-	10	-	mV
Zero Current Output Slope	$\Delta V_{OUT(Q)}$		-	0.22	-	mV/°C
Sensitivity Slope	$\Delta SENS$		-	0.003	-	mV/A/°C
Total Output Error	$E_{TOT}$		-2.0	-	2.0	%

**NOTE:** The following series exceeding 65A range cannot be powered continuously. Besides, the average current  $I_{RMS}$  can only be made  $\leq 65A$  with duty cycle (%)

## 75A PERFORMANCE CHARACTERISTICS

Parameter	Symbol	Conditions	Min.	Typ.	Max.	Unit
Current Accuracy Range	$I_P$	-	-75	-	75	A
Sensitivity	Sens	full range of $I_P$	17.1	17.6	18.1	mV/A
Zero Current Differential Output Error	$V_{OE}$		-10		10	mV
Noise	$V_{NOISE(RMS)}$		-	10	-	mV
Zero Current Output Slope	$\Delta V_{OUT(Q)}$		-	0.22	-	mV/°C
Sensitivity Slope	$\Delta SENS$		-	0.003	-	mV/A/°C
Total Output Error	$E_{TOT}$		-2.0	-	2.0	%

## 100A PERFORMANCE CHARACTERISTICS

Parameter	Symbol	Conditions	Min.	Typ.	Max.	Unit
Current Accuracy Range	$I_P$	-	-100	-	100	A
Sensitivity	Sens	full range of $I_P$	12.8	13.2	13.6	mV/A
Zero Current Differential Output Error	$V_{OE}$		-10		10	mV
Noise	$V_{NOISE(RMS)}$		-	10	-	mV
Zero Current Output Slope	$\Delta V_{OUT(Q)}$		-	0.22	-	mV/°C
Sensitivity Slope	$\Delta SENS$		-	0.002	-	mV/A/°C
Total Output Error	$E_{TOT}$		-2.0	-	2.0	%

**TYPICAL APPLICATION CIRCUITS**

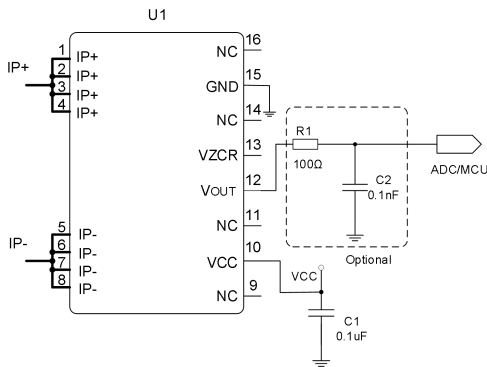

Typical Output Application

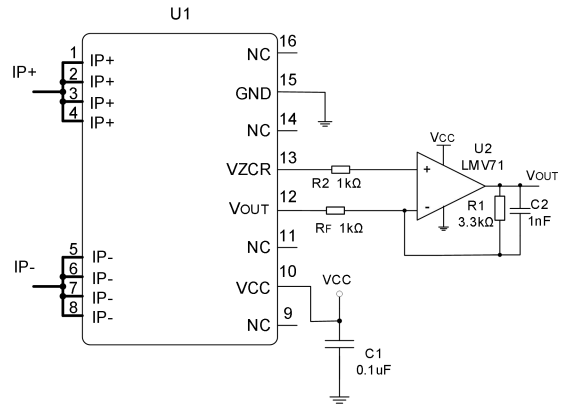

Gain amplifier application

Note: output direction of Vout

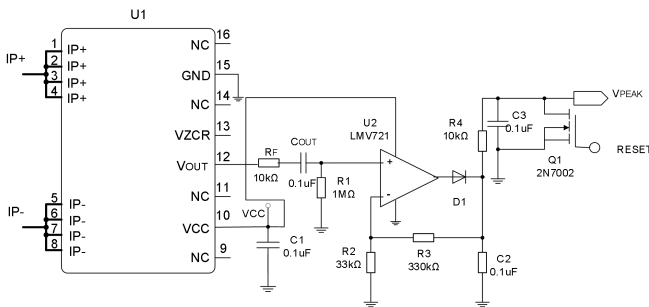

Peak Current Detection

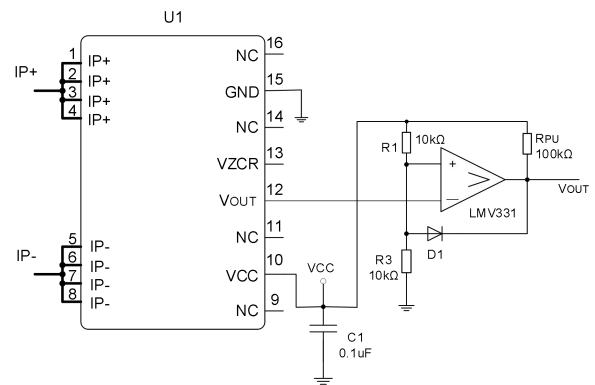

Over Current Fault Latch

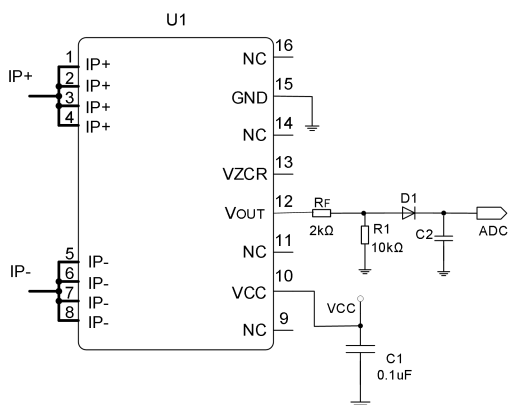

Rectifier output, instead of current transformer application

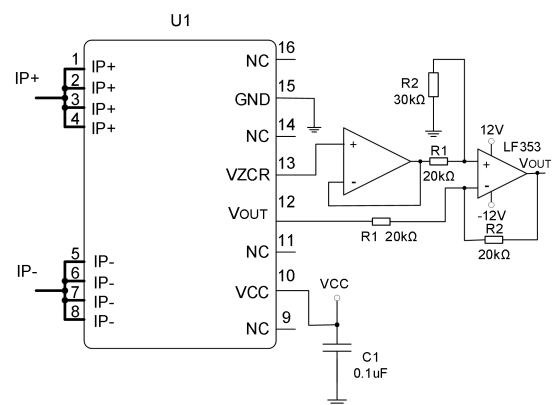

Zero Migration Application



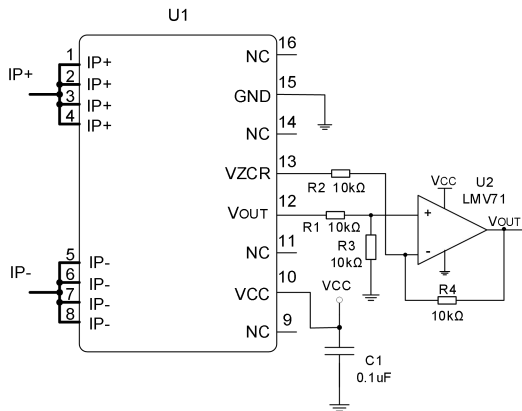

Application of single source zero shift with unidirectional current

**Note:** the output current of  $I_{zcr}$  is  $< 0.4\text{mA}$ . It is suggested that  $0.3\text{mA}$

---

## Function Description

The CC6921B device is a precision current sensor based on Hall sensor. It has 1000V<sub>RMS</sub> basic isolated working voltage, less than 3% full scale error and zero current reference signal output in the whole temperature range, which can realize unidirectional or bidirectional current detection. The input current flows through a wire between isolated input current pins, which has a resistance of 0.45 mΩ at room temperature to reduce insertion loss. The magnetic field generated by the input current is sensed by Hall sensor and amplified by precise signal chain. It can be used for AC and DC current measurement with a bandwidth of 250kHz. The measuring current is 5A~100A. There are 10 kinds of Current sensing range to choose. It can work under single power supply of 3.0V to 3.6V. CC6921B is optimized for high accuracy and temperature stability, compensating for misalignment and sensitivity over the entire range.

The input current of CC6921B flows through the primary side of the package through IP + and IP - pins. The current flowing through the chip generates a magnetic field proportional to the input current and is measured by an isolated Precision Hall sensor IC. Compared with other current measurement methods, the low impedance lead frame path reduces power consumption and does not require any external devices on the primary side. In addition, the internal integrated differential common mode suppression circuit can make the chip output not affected by external interference magnetic signal, and only measure the magnetic field generated by the input current, so as to suppress the interference of external magnetic field.

The typical resistance of the primary current input conductor at 25 ° C is 0.45 mΩ. The lead frame is made of copper. The temperature coefficient of the input wire is positive, and the wire resistance increases with the increase of temperature. The typical temperature coefficient is 3300 ppm/°C. For every 100 ° C increase in temperature, the primary side resistance will increase by 33%.

## Input Current

In use, the primary side of the chip (package pins 1-8) is connected in series at any position in the whole circuit. The input current flowing from IP + (package pins 1-4) to IP - (package pins 5-8) is positive, otherwise it is negative. Do not shunt resistors between IP + and IP -, unless there are very special reasons - such as minimizing insertion loss - which will reduce the current flowing through the chip, and the wire resistance will also be affected by temperature drift, which requires external temperature and precision correction of the whole system.

## Output Characteristic

The static output point (IP = 0A) of CC6921B is  $V_{CC} / 2$ .

When the current increases, the  $V_{OUT}$  increases until the saturation voltage of the output operational amplifier ( $V_{CC} - \text{rail voltage}$ ); when the current decreases, the  $V_{OUT}$  decreases until the saturation voltage ( $GND + \text{rail voltage}$ ) of the Output Op Amp. Crosschip ensures the accuracy and linearity of  $V_{OUT}$  in the range of 0.33 ~ 2.97V. In order to ensure the consistency of mass manufacturing, there is a certain margin in this range, but it is not recommended for customers to use this margin.

When the input current exceeds the range, the output of  $V_{OUT}$  is close to the rail voltage of the power supply. When the input current does not exceed the tolerance limit of the chip, the voltage will always be maintained. After the input current returns to the range, the output of  $V_{OUT}$  will return to normal without any damage to the chip.

Product Name	Input Current	Sensitivity(mV/A)	Calculation Formula (Note 1)
CC6921BSO-5A	-5A ~ +5A	400	$V_{OUT} = VCC / 2 + 0.4 \times I_P(A) \dots\dots(V)$
CC6921BSO-10A	-10A ~ +10A	132	$V_{OUT} = VCC / 2 + 0.132 \times I_P(A) \dots\dots(V)$
CC6921BSO-20A	-20A ~ +20A	66	$V_{OUT} = VCC / 2 + 0.066 \times I_P(A) \dots\dots(V)$
CC6921BSO-25A	-25A ~ +25A	52.8	$V_{OUT} = VCC / 2 + 0.0528 \times I_P(A) \dots\dots(V)$
CC6921BSO-30A	-30A ~ +30A	44	$V_{OUT} = VCC / 2 + 0.044 \times I_P(A) \dots\dots(V)$
CC6921BSO-40A	-40A ~ +40A	33	$V_{OUT} = VCC / 2 + 0.033 \times I_P(A) \dots\dots(V)$
CC6921BSO-50A	-50A ~ +50A	26.4	$V_{OUT} = VCC / 2 + 0.0264 \times I_P(A) \dots\dots(V)$
CC6921BSO-65A	-65A ~ +65A	20.3	$V_{OUT} = VCC / 2 + 0.0203 \times I_P(A) \dots\dots(V)$
CC6921BSO-75A	-75A ~ +75A	17.6	$V_{OUT} = VCC / 2 + 0.0176 \times I_P(A) \dots\dots(V)$
CC6921BSO-100A	-100A ~ +100A	13.2	$V_{OUT} = VCC / 2 + 0.0132 \times I_P(A) \dots\dots(V)$

**Note** : the formula is only applicable to DC current calculation. When AC current is applied, pay attention to  $I_{PEAK} = 1.414 \times I_{RMS}$  and the positive & negative current direction.

## Relationship between Package Temperature & Input Current

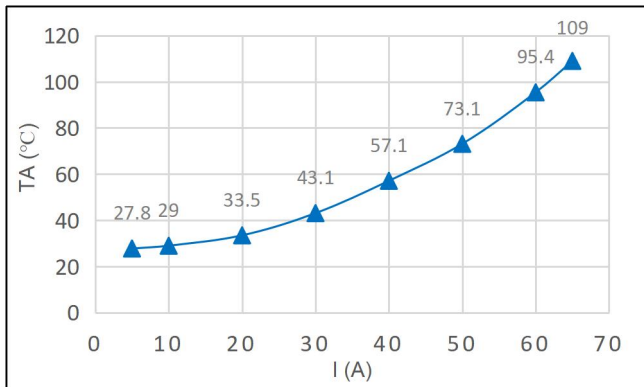

Input Current (IP) vs. Package temperature

**Note:** Based on the demo board test, for specific applications, it is necessary to strengthen the heat dissipation according to the actual application scenario or select the board with high Tg.

For example: Temperature tests shall be considered for the specific installation conditions in end system which needs a cooling system that can provide wind speeds of at least 13.8 m/s.

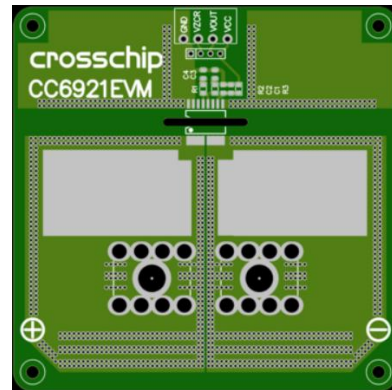

Thickness: 1.6mm, FR-4 double-sided plate, 4oz copper foil  
total 10000m<sup>2</sup>

Test environment: open environment, stagnant air

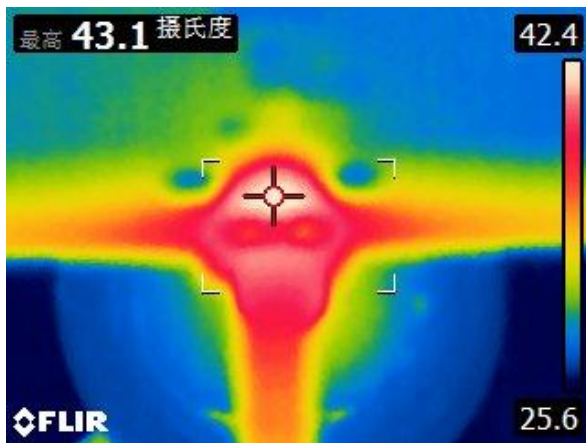

Package Thermography (Input Current 30A)

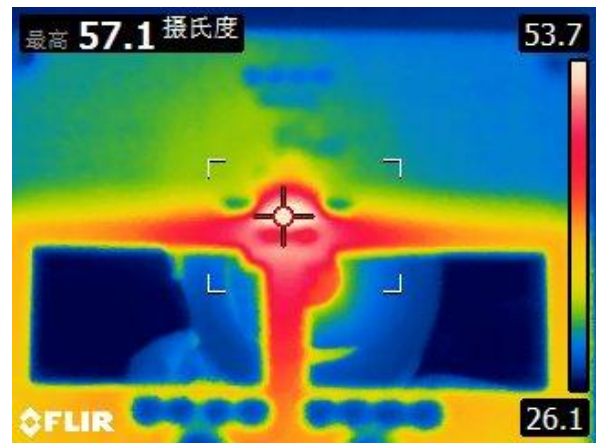

Package Thermography (Input Current 40A)

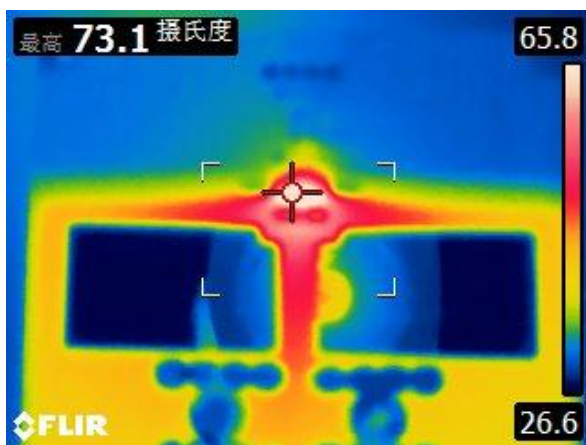

Package Thermography (Input Current 50A)

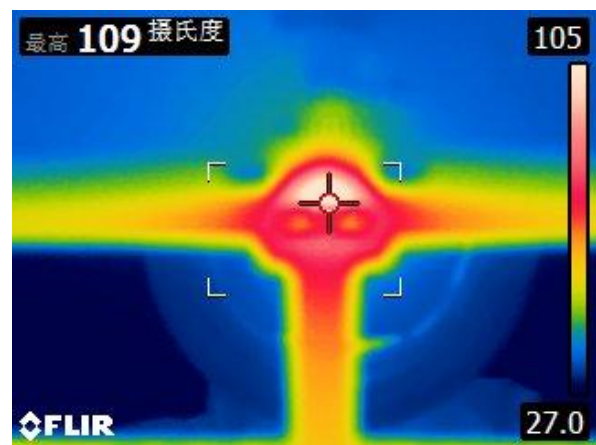

Package Thermography (Input Current 65A)

## OUTPUT WAVEFORMS AND CURVES

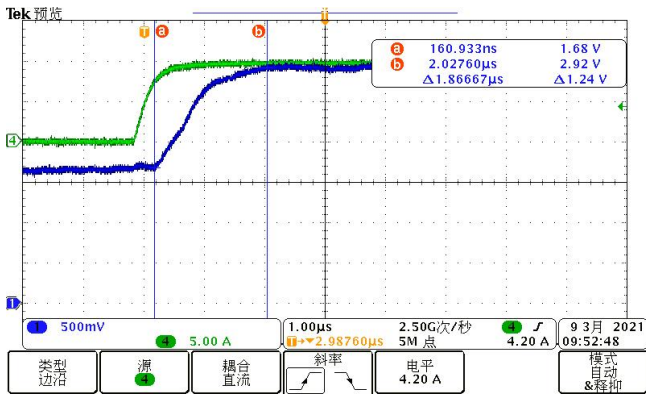

V<sub>OUT</sub> vs I<sub>P</sub> (10A)

(Positive Current Rising Edge Response)

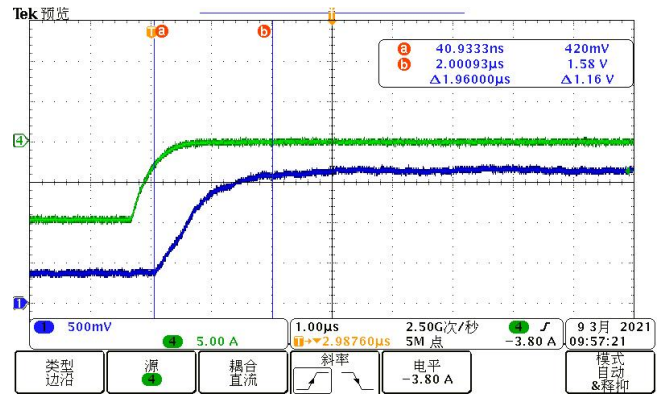

V<sub>OUT</sub> vs I<sub>P</sub> (10A)

(Negative Current Rising Edge Response)

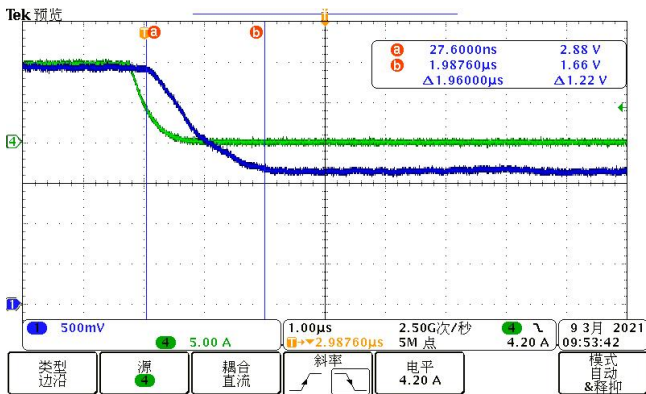

V<sub>OUT</sub> vs I<sub>P</sub> (10A)

(Positive Current Falling Edge Response)

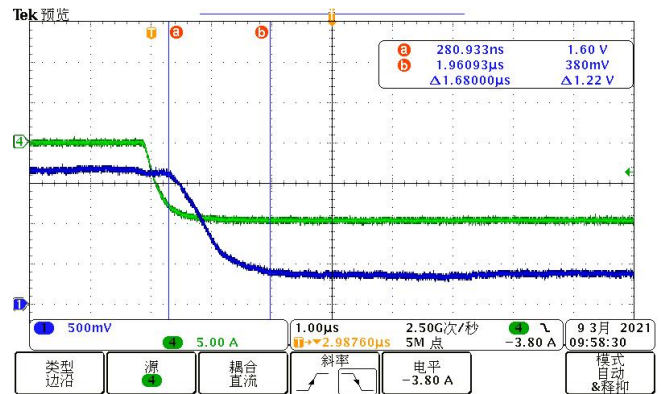

V<sub>OUT</sub> vs I<sub>P</sub> (10A)

(Negative Current Falling Edge Response)

## OUTPUT WAVEFORMS AND CURVES

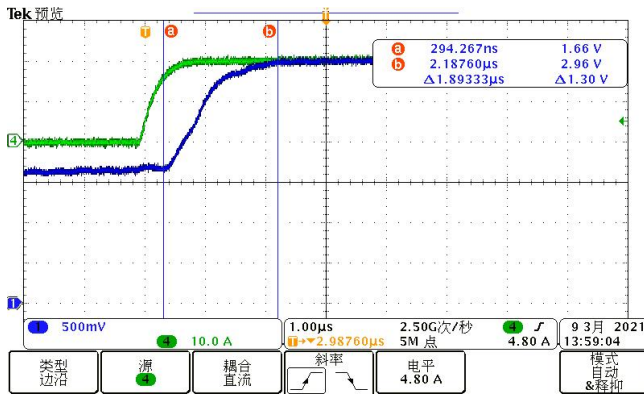

V<sub>out</sub> vs I<sub>P</sub> (20A)

(Positive Current Rising Edge Response)

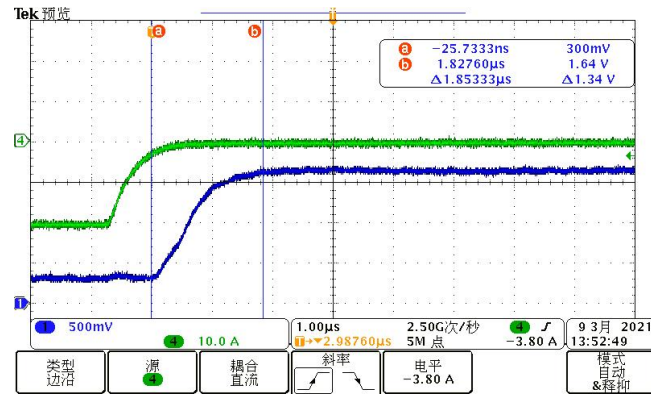

V<sub>out</sub> vs I<sub>P</sub> (20A)

(Negative Current Rising Edge Response)

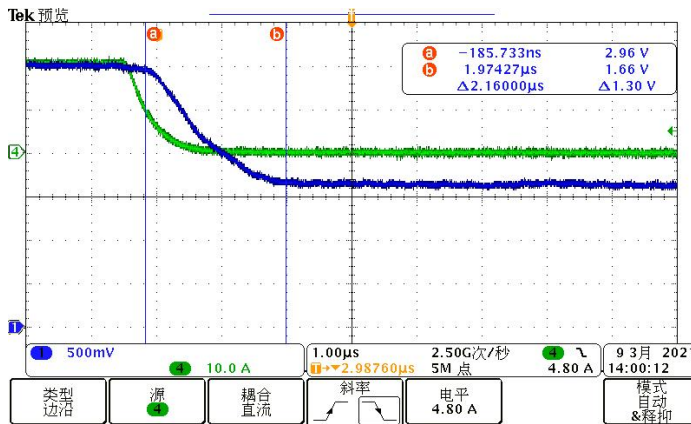

V<sub>out</sub> vs I<sub>P</sub> (20A)

(Positive Current Falling Edge Response)

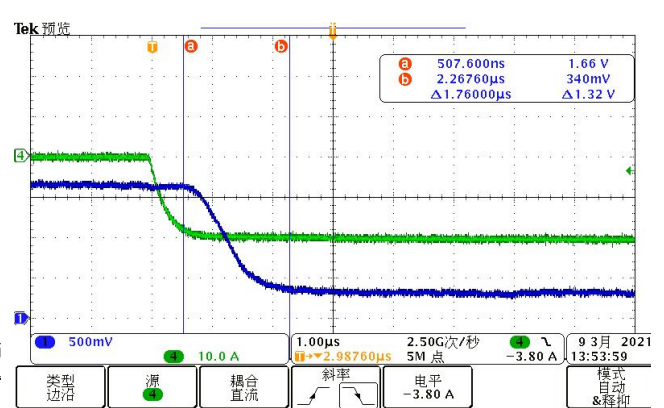

V<sub>out</sub> vs I<sub>P</sub> (20A)

(Negative Current Falling Edge Response)

## OUTPUT WAVEFORMS AND CURVES

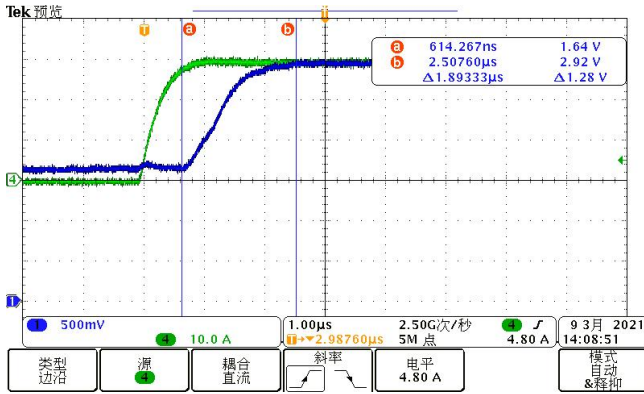

V<sub>OUT</sub> vs I<sub>P</sub> (30A)

(Positive Current Rising Edge Response)

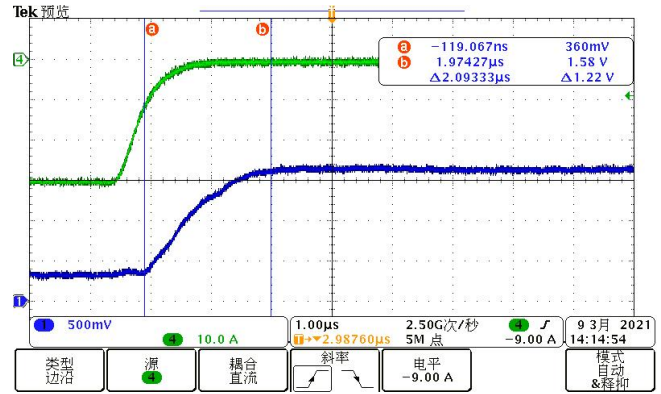

V<sub>OUT</sub> vs I<sub>P</sub> (30A)

(Negative Current Rising Edge Response)

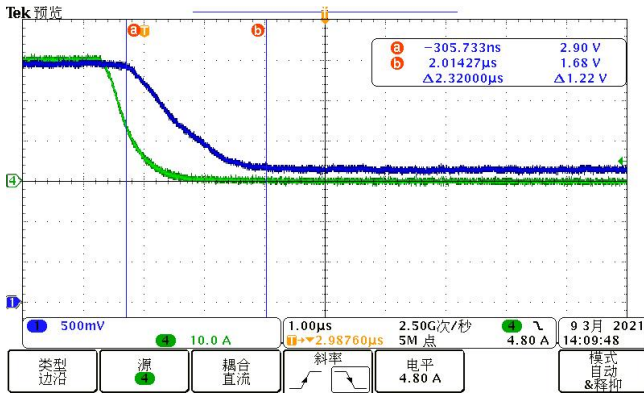

V<sub>OUT</sub> vs I<sub>P</sub> (30A)

(Positive Current Falling Edge Response)

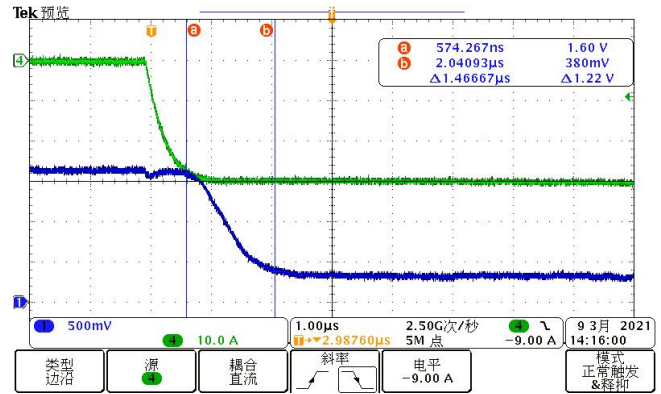

V<sub>OUT</sub> vs I<sub>P</sub> (<30A)

(Negative Current Falling Edge Response)

## OUTPUT WAVEFORMS AND CURVES

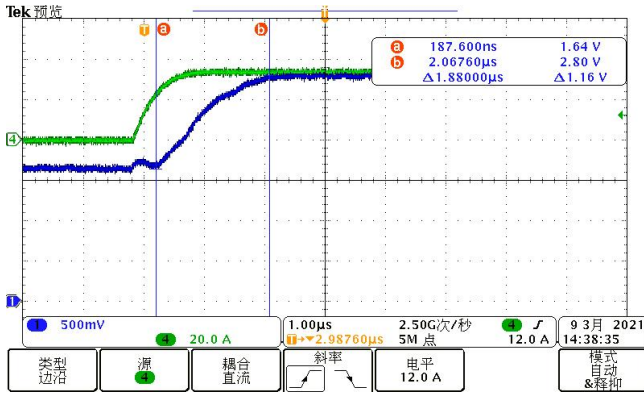

V<sub>OUT</sub> vs IP (40A)

(Positive Current Rising Edge Response)

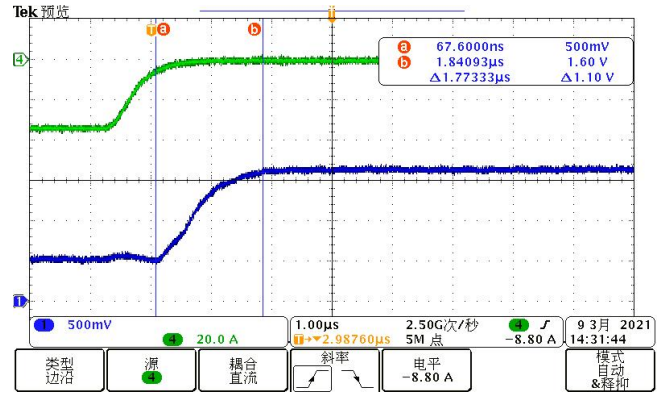

V<sub>OUT</sub> vs IP (40A)

(Negative Current Rising Edge Response)

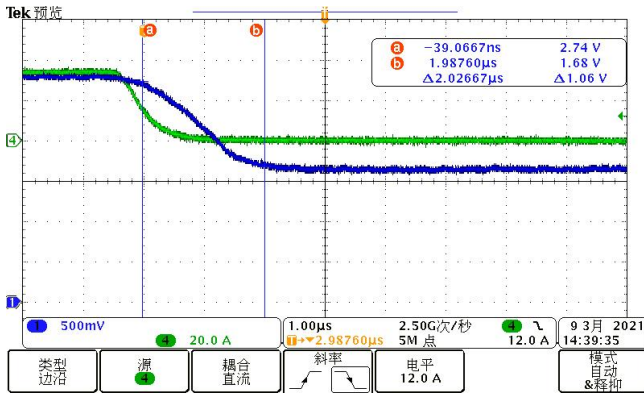

V<sub>OUT</sub> vs IP (40A)

(Positive Current Falling Edge Response)

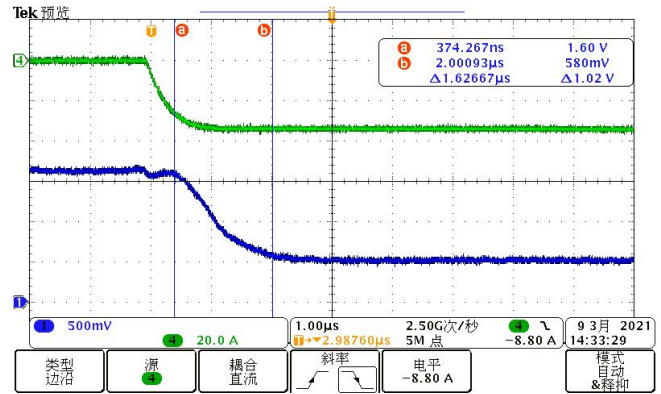

V<sub>OUT</sub> vs IP (40A)

(Negative Current Falling Edge Response)



**10A Series**

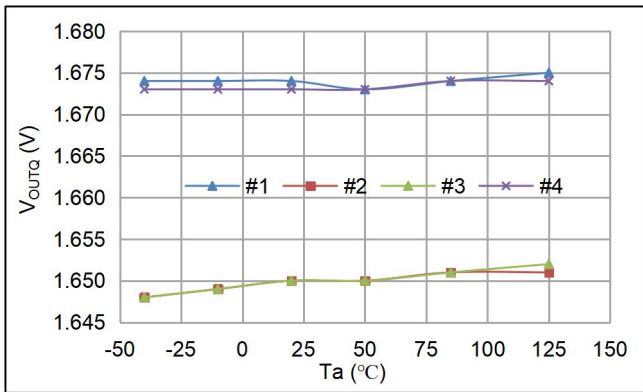

V<sub>outq</sub> vs. T<sub>a</sub>

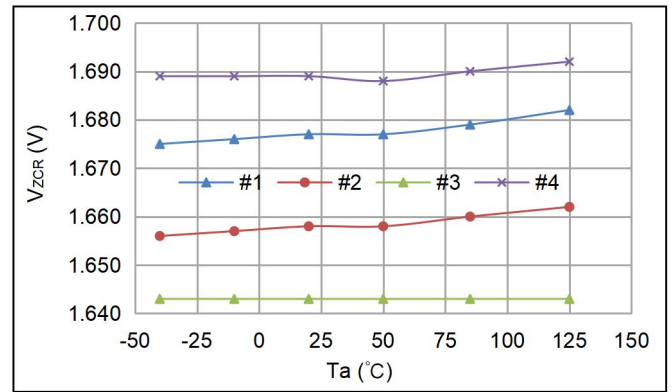

V<sub>zcr</sub> vs. T<sub>a</sub>

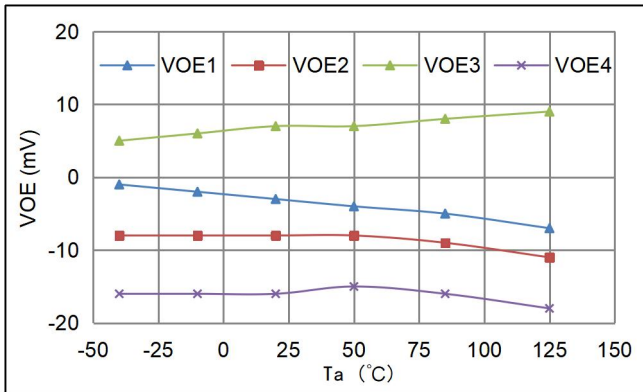

V<sub>oe</sub> vs. T<sub>a</sub>

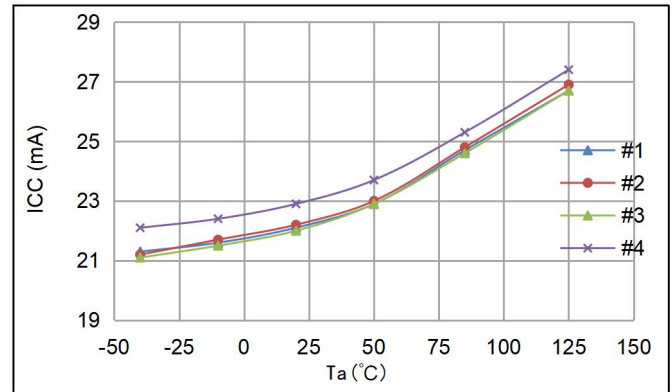

ICC vs. T<sub>a</sub>

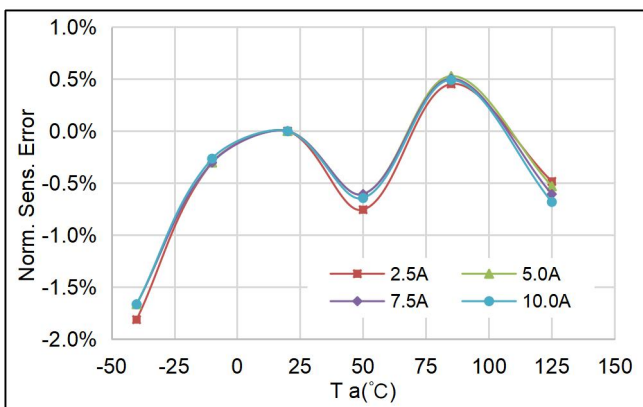

Sens error vs. T<sub>a</sub>

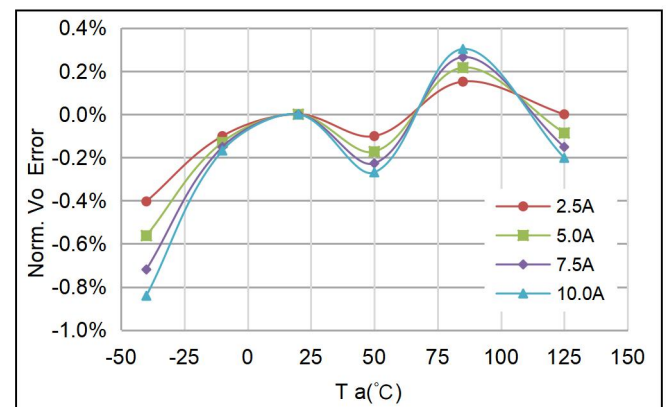

V<sub>out</sub> error vs. T<sub>a</sub>

20A Series

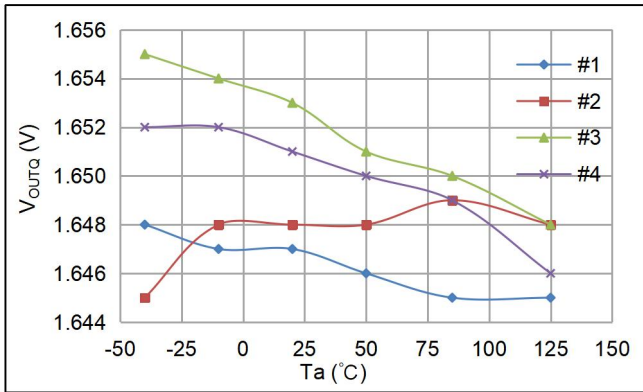

$V_{outq}$  vs.  $T_a$

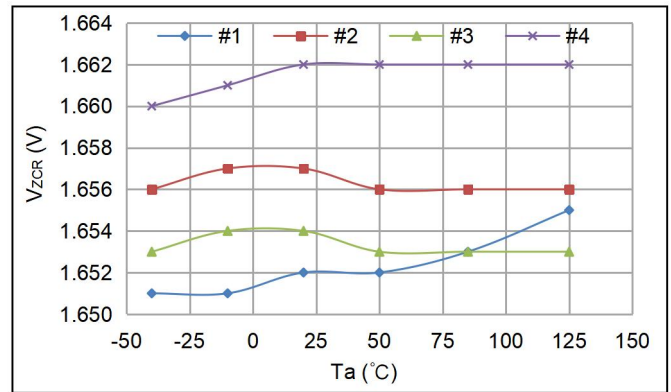

$V_{zcr}$  vs.  $T_a$

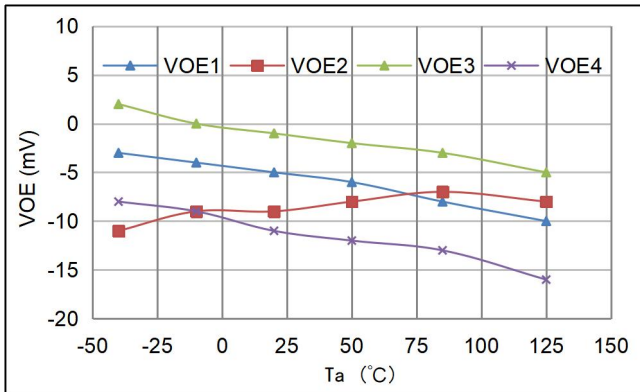

$VOE$  vs.  $T_a$

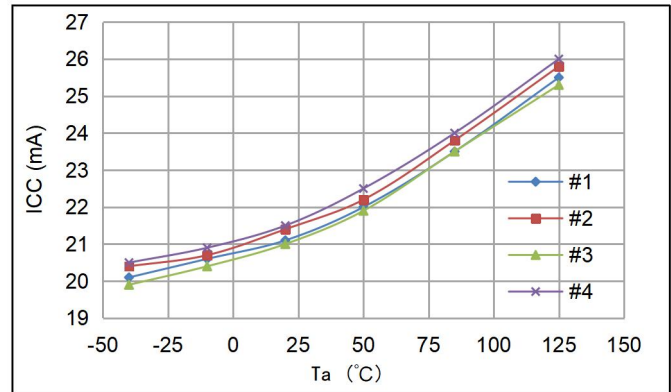

$ICC$  vs.  $T_a$

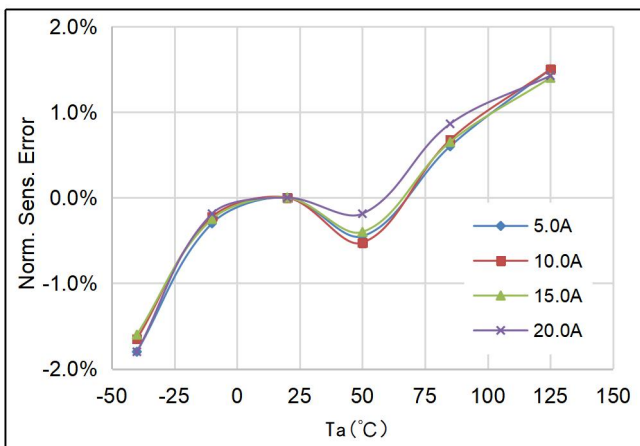

Sens error vs.  $T_a$

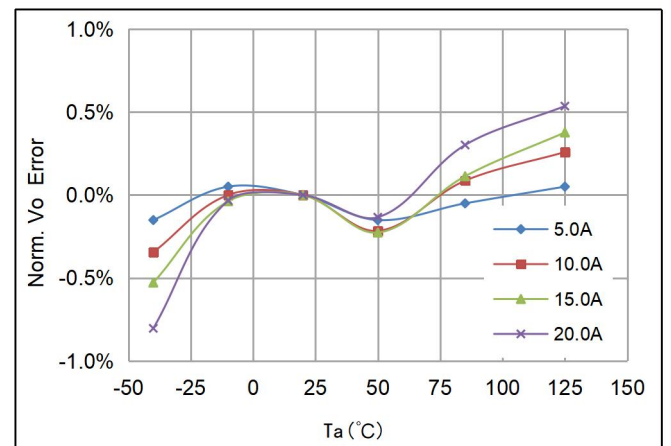

$V_{out}$  error vs.  $T_a$

**30A Series**

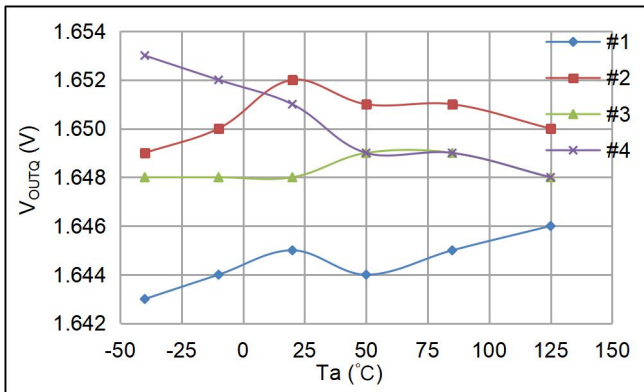

$V_{outQ}$  vs.  $T_a$

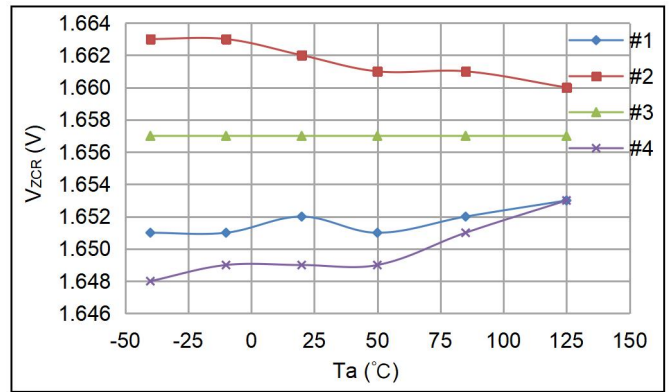

$V_{zCR}$  vs.  $T_a$

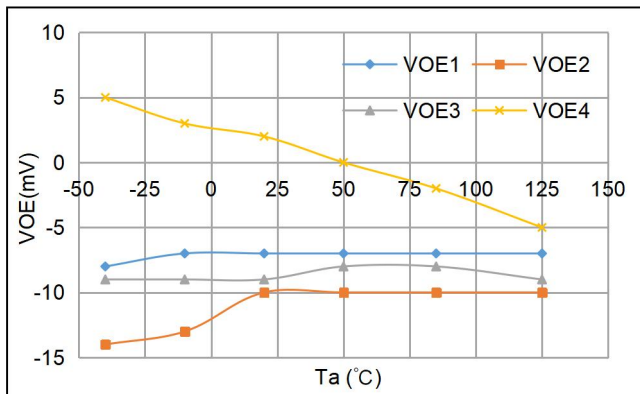

$V_{oe}$  vs.  $T_a$

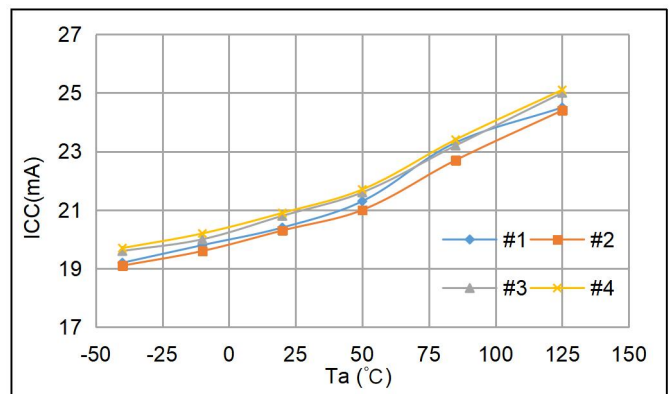

$ICC$  vs.  $T_a$

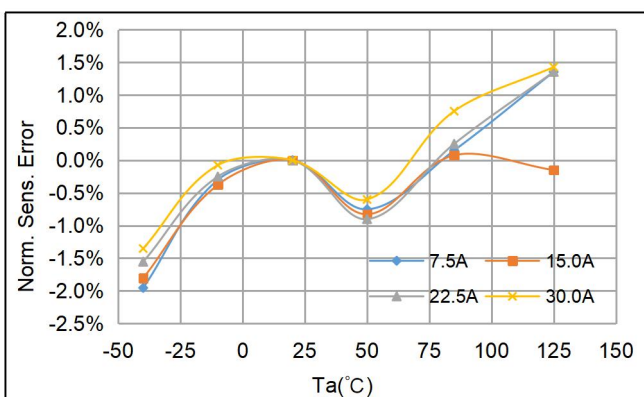

Sens error vs.  $T_a$

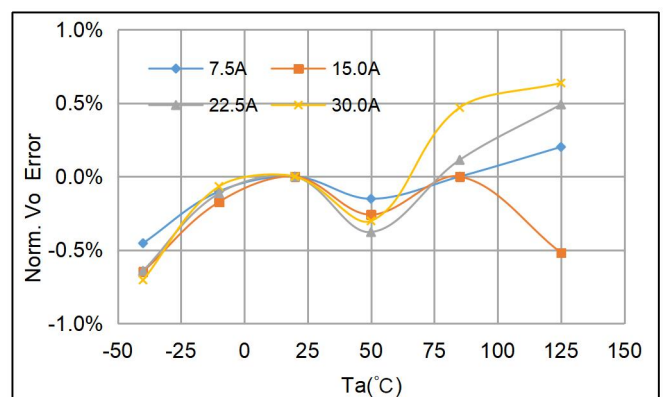

$V_{out}$  error vs.  $T_a$

40A Series

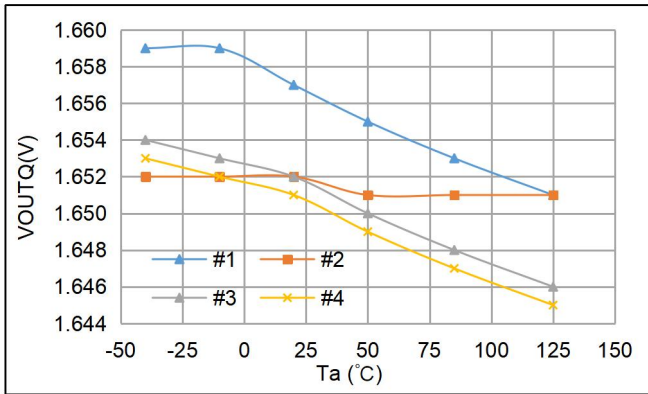

$V_{outQ}$  vs.  $T_a$

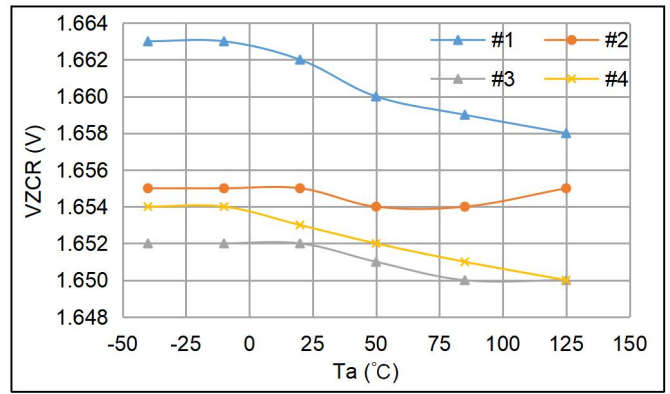

$V_{zCR}$  vs.  $T_a$

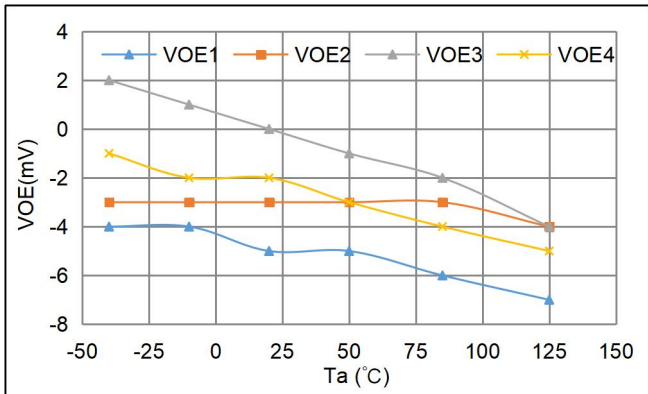

$V_{oe}$  vs.  $T_a$

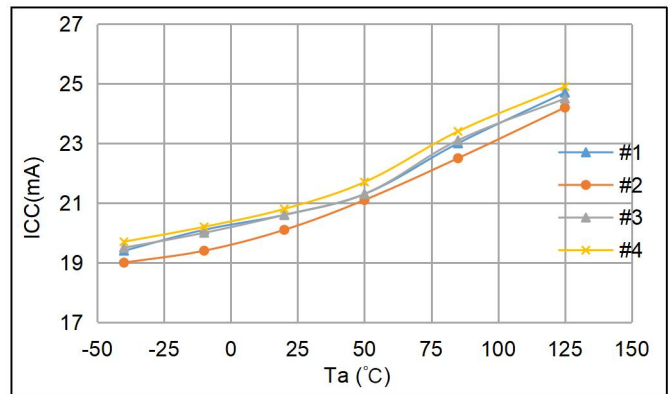

$I_{CC}$  vs.  $T_a$

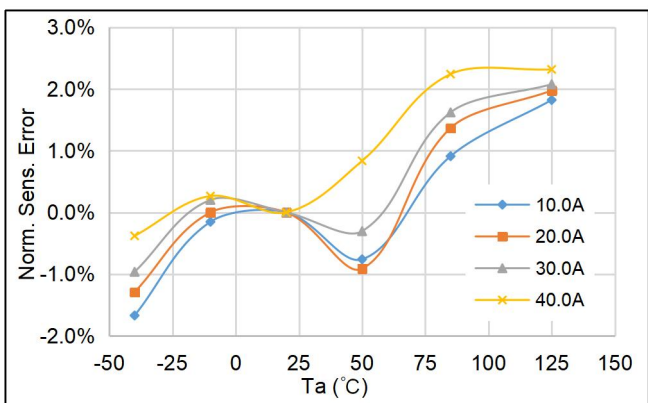

Sens error vs.  $T_a$

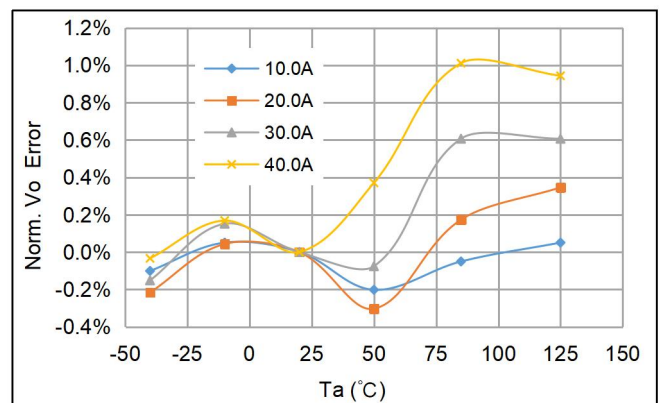

$V_{out}$  error vs.  $T_a$

**PACKAGE INFORMATION**

**SOP16W PACKAGE**

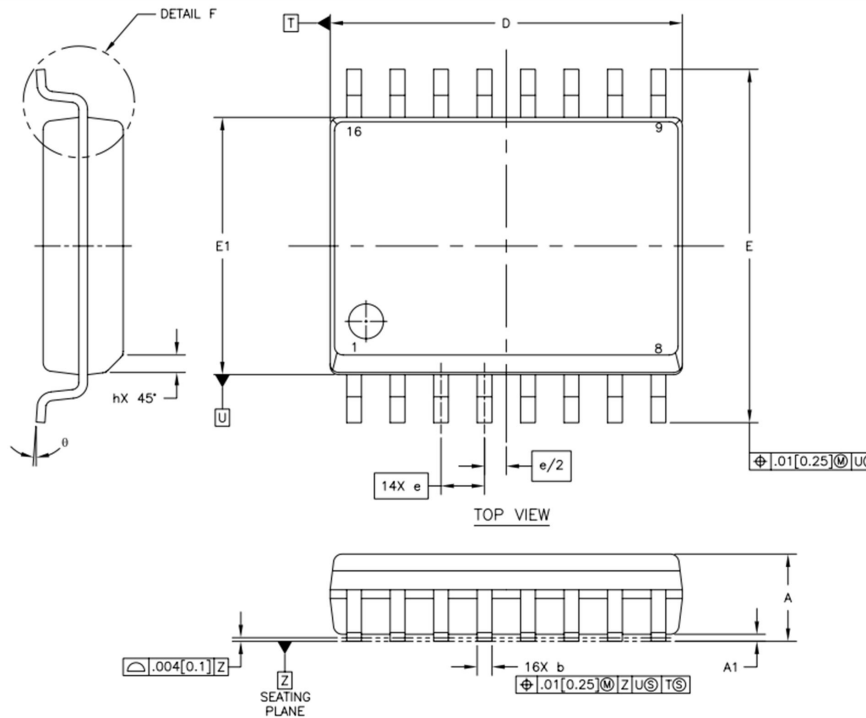

Symbol	Millimeters		
	Min	TYP	Max
A	2.35		2.65
A1	0.10		0.30
b	0.33		0.51
c	0.23		0.32
D	10.10		10.50
E1	7.40		7.60
E	10.00		10.63
e	1.27 BSC		
L	0.40		1.27
h	0.25		0.75
$\theta$	0°		8°

**Note:**

1. All dimensions are in millimeters.

**Marking:**

1<sup>st</sup> Line: CC6921BSO

2<sup>nd</sup> Line: ELC-XXA

XX— $I_p$  Range

3<sup>rd</sup> Line: XYYWW

XX—assembly code

YY—assembly year (last 2 digits)

WW—assembly week number

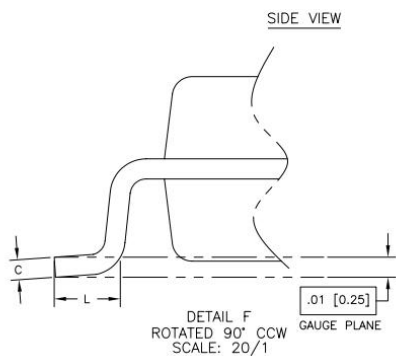

Package Reference

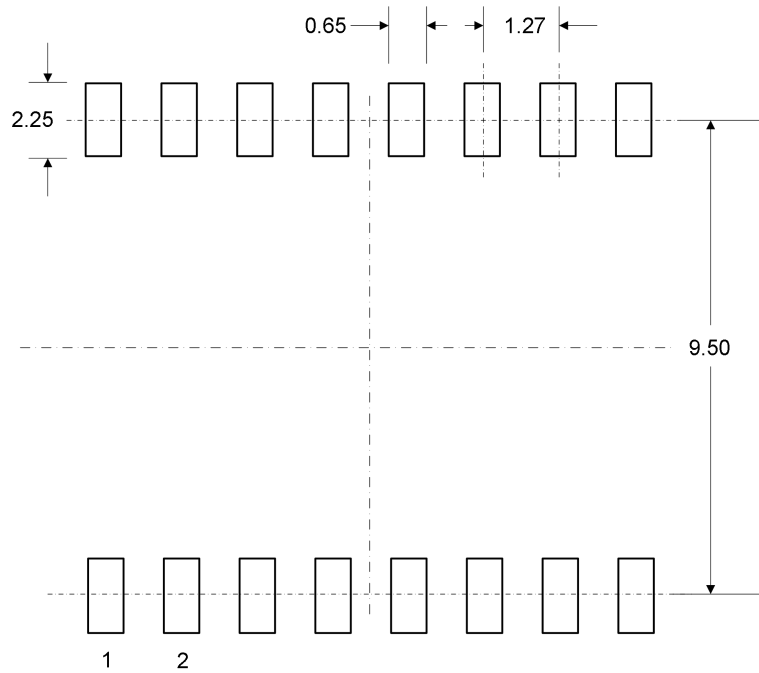

Reference: shorten pad length and increase creepage distance

---

## CrossChip

CrossChip Microsystems Inc. was founded in 2013, is a national high-tech enterprise, engaged in integrated circuit design and sales. The company has strong technical strength, has more than 50 kinds of patents, mainly used in Hall sensor signal processing, with the following product lines:

- ✓ High precision linear Hall sensor
- ✓ All kinds of Hall switches
- ✓ Single phase motor drive
- ✓ Single chip current sensor
- ✓ AMR Magnetoresistance sensor

## Contact us

### Chengdu

Address: 4th floor, unit 2, building 3, No. 88, Tianchen Road, Gaoxinxi Zone, Chengdu, Sichuan Province

Tel: + 86 - 28 - 87787685

Email: [support@crosschipmicro.com](mailto:support@crosschipmicro.com)

Website: <http://www.crosschipmicro.com>

### Shenzhen

Address: 605 room, 6F, Beike building, NO.18 Keyuan Rd, Yuehai Street, Nanshan District, Shenzhen

### Shanghai

Address: Makeblock, 3 / F, magic square community, 4476 Huyi Road, Jiading District, Shanghai