

Dec.1.2023 Copyright 2023 HIROSE ELECTRIC CO., LTD. All Rights Reserved.
In case of consideration for using Automotive equipment / device which demand high reliability, kindly contact our sales window correspondents.

Contact No.1 marking

Recommended PCB layout
Recommended metal mask (thickness:0.1mm)

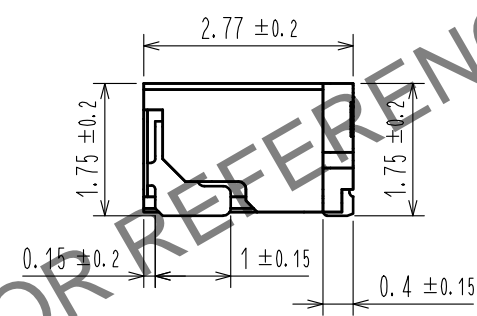
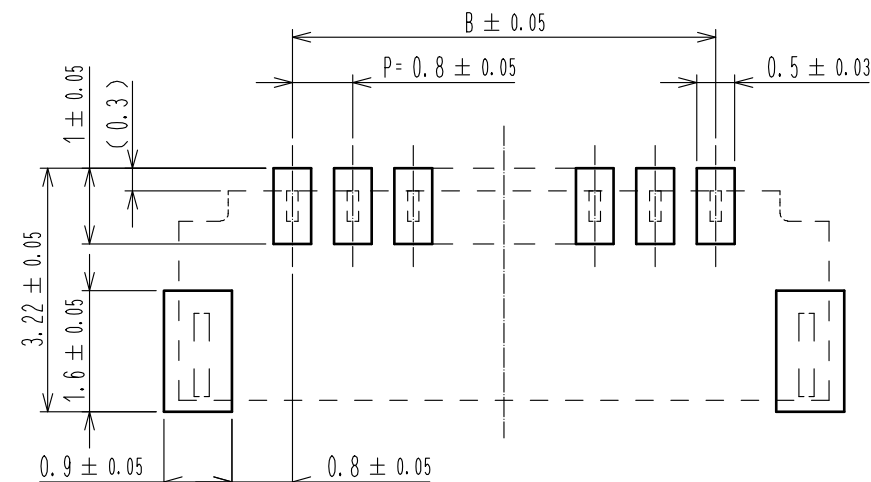
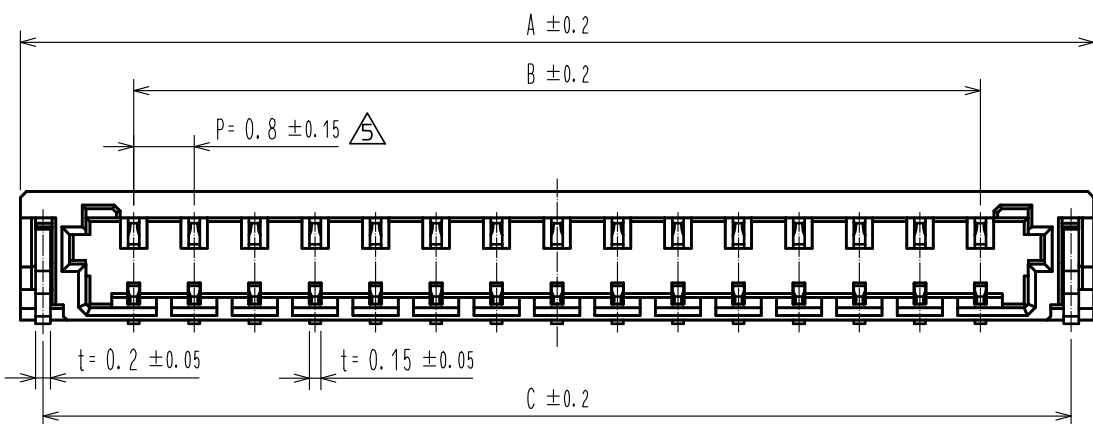

Mating Figure (Free)

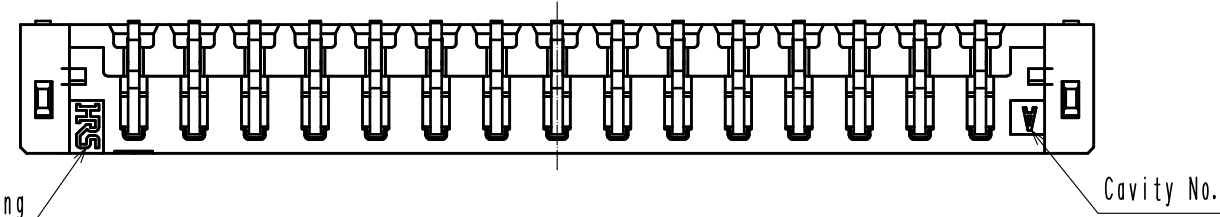
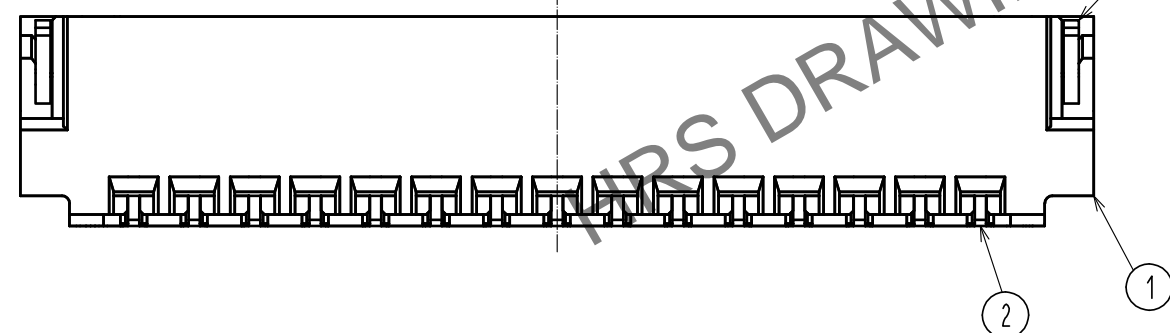
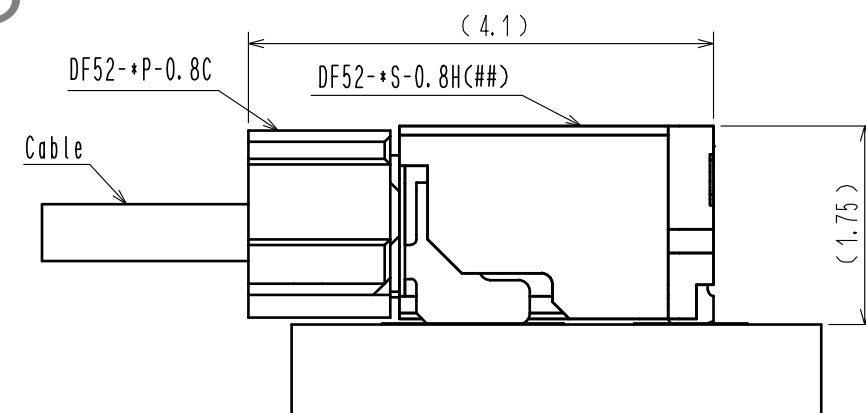

Part No.	Code No.	A	B	C
DF52-2S-0.8H(21)	CL0668-0004-5-21	3.8	0.8	3.2
DF52-3S-0.8H(21)	CL0668-0022-7-21	4.6	1.6	4.0
DF52-4S-0.8H(21)	CL0668-0005-8-21	5.4	2.4	4.8
DF52-5S-0.8H(21)	CL0668-0023-0-21	6.2	3.2	5.6
DF52-6S-0.8H(21)	CL0668-0006-0-21	7.0	4.0	6.4
DF52-8S-0.8H(21)	CL0668-0007-3-21	8.6	5.6	8.0
DF52-10S-0.8H(21)	CL0668-0008-6-21	10.2	7.2	9.6
DF52-12S-0.8H(21)	CL0668-0009-9-21	11.8	8.8	11.2
DF52-14S-0.8H(21)	CL0668-0024-2-21	13.4	10.4	12.8
DF52-15S-0.8H(21)	CL0668-0010-8-21	14.2	11.2	13.6
DF52-16S-0.8H(21)	CL0668-0025-5-21	15.0	12.0	14.4
DF52-17S-0.8H(21)	CL0668-0001-7-21	15.8	12.8	15.2
DF52-20S-0.8H(21)	CL0668-0011-0-21	18.2	15.2	17.6

3	Brass Δ	Surface:tin plating 1 μ mMIN	6	PS	Black(Reel)
2	Copper alloy	Surface:tin plating 1 μ mMIN	5	Polyester	Clear(Cover tape), ANTI-STATIC
1	Polyamide	Black, UL94V-0	4	PS	Clear(Embossed carrier tape), ANTI-STATIC
NO.	MATERIAL	FINISH . REMARKS	NO.	MATERIAL	FINISH . REMARKS

Note 1. Lead co-planarity shall be 0.1mm MAX.
2. Please consult HIROSE when the product is mounted to FPC.

UNITS mm	\odot \triangleleft	SCALE 10:1	COUNT 2	DESCRIPTION OF REVISIONS DIS-H-00003668	DESIGNED HK. HAYASHI	CHECKED TS. FUKUSHIMA	DATE 18.03.22
HRS HIROSE ELECTRIC CO., LTD.		APPROVED : KI. AKIYAMA 14.06.27	DRAWING NO. EDC3-356517-01				
		CHECED : HK. UMEHARA 14.06.27	PART NO. DF52-*S-0.8H(21)				
		DESIGNED : TH. YOSHIZAWA 14.06.26	CODE NO. CL668-				
		DRAWN : TH. YOSHIZAWA 14.06.26					

Dec.1.2023 Copyright 2023 HIROSE ELECTRIC CO., LTD. All Rights Reserved.
 In case of consideration for using Automotive equipment / device which demand high reliability, kindly contact our sales window correspondents.

Drawing for packing (Free)

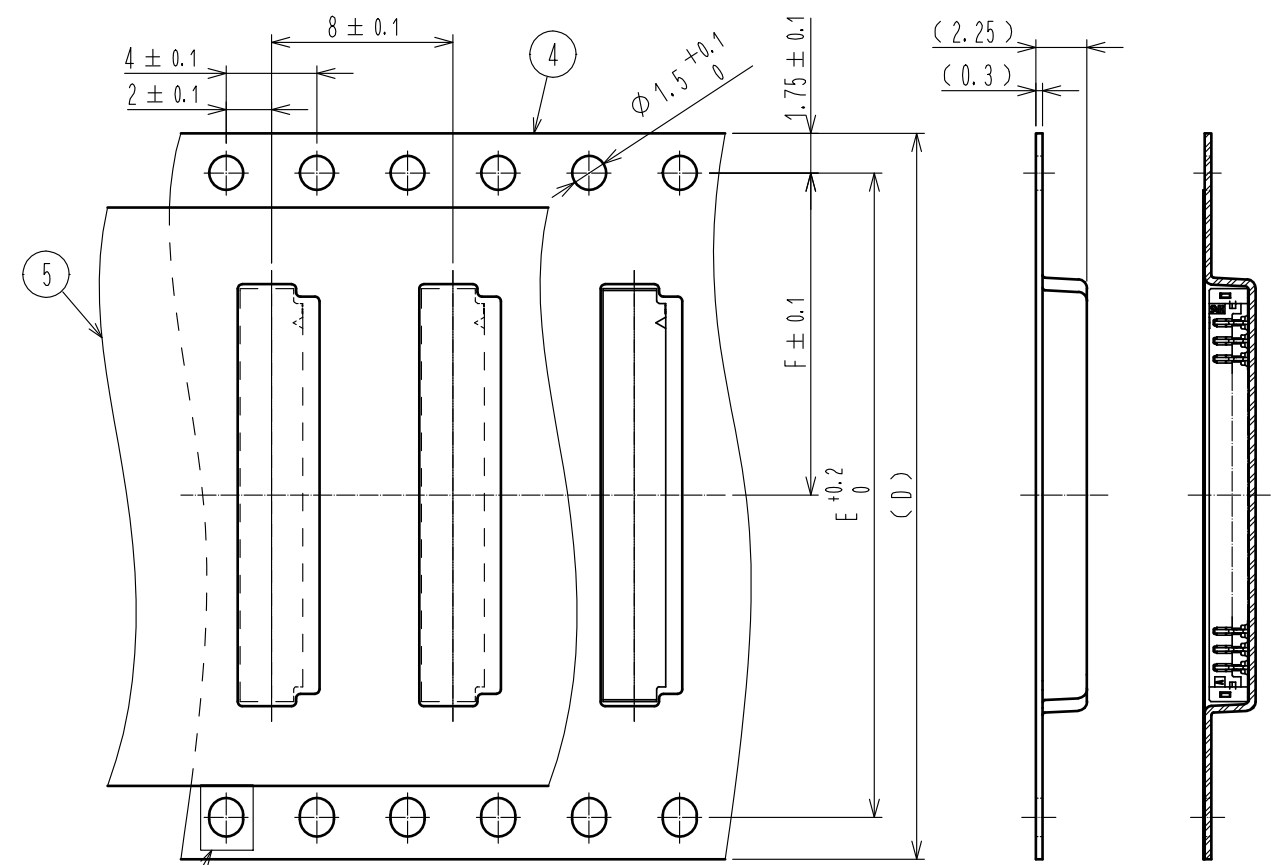

Style and dimension of reel (Free)

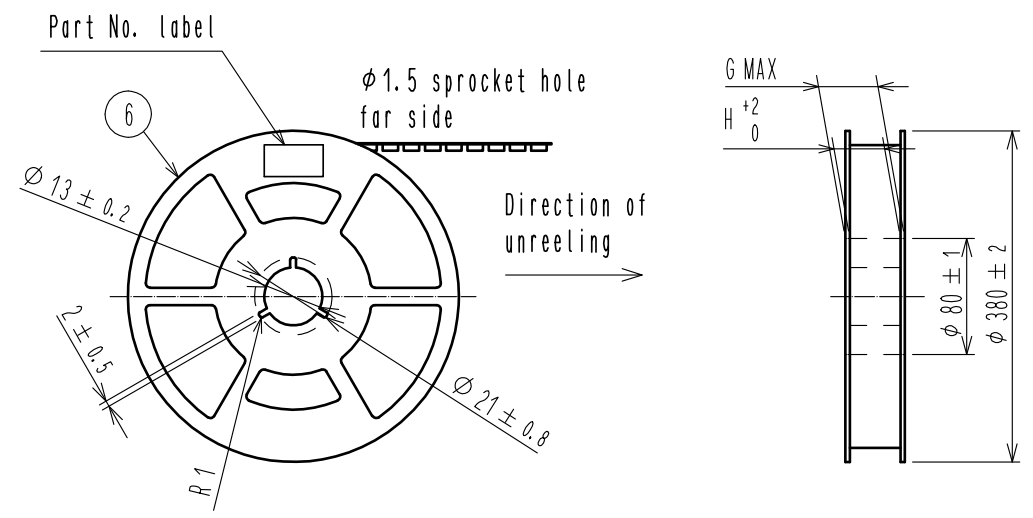

Detail of part No. label

Lot No.	170 7010	◁ 7
CL Code	CL0668-0001-7-21	
品名 (Part Number)	DF52-17S-0.8H(21)	
納入数量 (Qty)	5000 K0	
ヒロセ電機(株)		

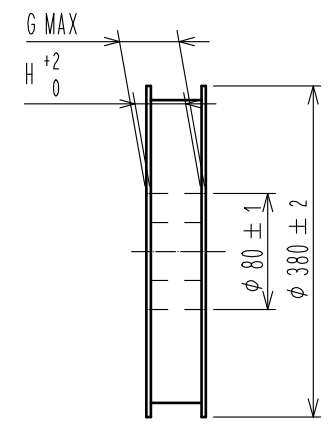

Direction of unreeling



Taping (Free)

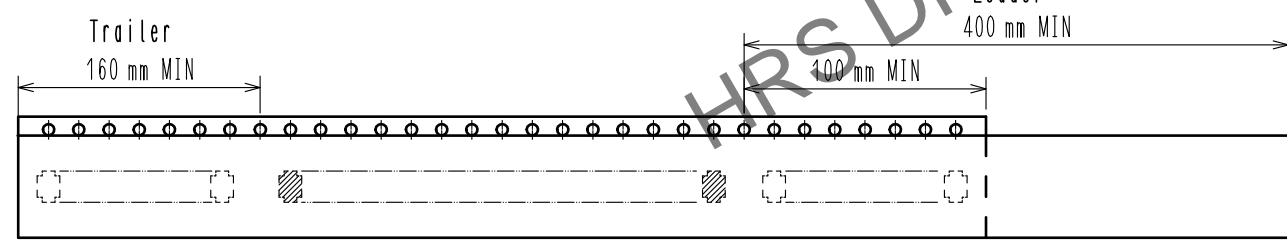

◁ 5 J(10:1)

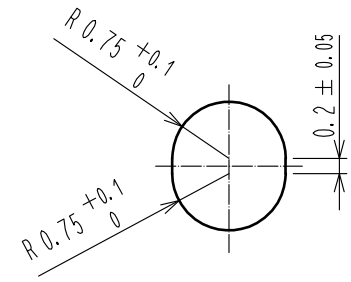

Reflow temperature profile using lead-free solder paste (Reference)

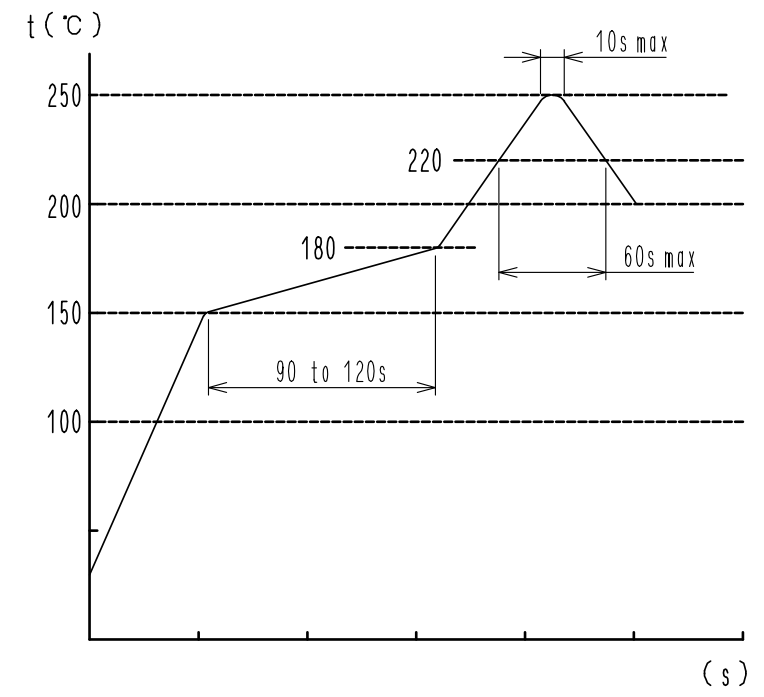

Number of reflow cycles 2 cycles MAX.
 The temperature is measured in the terminal lead part.

Additional factors, such as solder paste type, PCB size and other mounted components could affect the profile, therefore, a thorough evaluation of mounting condition is required prior to production.

- Note
- 1 reel: 5000 connectors.
 - () is reference dimension.
 - ◁ 5 When the tape width is 32mm, sprocket holes shall be set on both side of reel as shown on this drawing.
 - ◁ 6 Refer to JIS C 0806. (Packaging of components for automating handling)
 - ◁ 7 Each meaning of Lot No. are shown below.

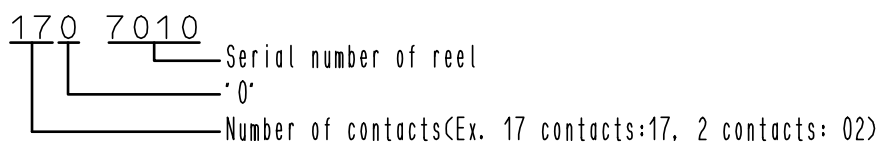

Part No.	Code No.	D	E	F	G	H
DF52-2S-0.8H(21)	CL0668-0004-5-21	16.0	/	7.5	22.4	16.4
DF52-3S-0.8H(21)	CL0668-0022-7-21	16.0	/	7.5	22.4	16.4
DF52-4S-0.8H(21)	CL0668-0005-8-21	16.0	/	7.5	22.4	16.4
DF52-5S-0.8H(21)	CL0668-0023-0-21	16.0	/	7.5	22.4	16.4
DF52-6S-0.8H(21)	CL0668-0006-0-21	16.0	/	7.5	22.4	16.4
DF52-8S-0.8H(21)	CL0668-0007-3-21	24.0	/	11.5	30.4	24.4
DF52-10S-0.8H(21)	CL0668-0008-6-21	24.0	/	11.5	30.4	24.4
DF52-12S-0.8H(21)	CL0668-0009-9-21	24.0	/	11.5	30.4	24.4
DF52-14S-0.8H(21)	CL0668-0024-2-21	24.0	/	11.5	30.4	24.4
DF52-15S-0.8H(21)	CL0668-0010-8-21	24.0	/	11.5	30.4	24.4
DF52-16S-0.8H(21)	CL0668-0025-5-21	24.0	/	11.5	30.4	24.4
DF52-17S-0.8H(21)	CL0668-0001-7-21	24.0	/	11.5	30.4	24.4
DF52-20S-0.8H(21)	CL0668-0011-0-21	32.0	28.4	14.2	38.4	32.4

HRS	DRAWING NO.	EDC3-356517-01
	PART NO.	DF52-*S-0.8H(21)
	CODE NO.	CL0668-