



## SS22L THRU SS220L

VOLTAGE RANGE

20 to 200 Volts

CURRENT

2.0 Ampere



## Features

- Low profile surface mount package
- Built in strain relief
- High switching speed
- Low voltage drop, high efficiency
- For use in low voltage high frequency inverters, Free willing ,and polarity protection applications
- Guardring for over voltage protection



DO-214AC (SMA)

## Mechanical Data

- Case: Transfer molded plastic
- Epoxy: UL 94V-0 rate flame retardant
- Lead :Solder plated, solderable per MIL-STD-750 method 2026
- Polarity: Color band denotes cathode end
- Weight: 0.002 ounce, 0.064 gram

## Maximum Ratings and Electrical Characteristics

- Ratings at 25°C ambient temperature unless otherwise specified.
- Single phase, half wave, 60Hz, resistive or inductive load.
- For capacitive load derate current by 20%.

TYPE NUMBER	SYMBOLS	SS 22L	SS 24L	SS 25L	SS 26L	SS 28L	SS 210L	SS 215L	SS 220L	UNIT
Maximum Repetitive Peak Reverse Voltage	$V_{RRM}$	20	40	50	60	80	100	150	200	Volts
Maximum RMS Voltage	$V_{RMS}$	14	28	35	42	56	70	105	140	Volts
Maximum DC Blocking Voltage	$V_{DC}$	20	40	50	60	80	100	150	200	Volts
Maximum Average Forward Rectified Current at $T_J$ see figure 1 $T_J = 80^\circ\text{C}$	$I_{(AV)}$	2.0								Amps
Peak Forward Surge Current 8.3ms single half sine-wave superimposed on rated load (JEDEC method)	$I_{FSM}$	50								Amps
Maximum Instantaneous Forward Voltage @ 2.0A <sup>(Note1)</sup>	$V_F$	0.45		0.60		0.70		0.85		Volts
Maximum DC Reverse Current at rated DC Blocking Voltage per element	$T_A = 25^\circ\text{C}$	0.5						0.1		mA
	$T_A = 100^\circ\text{C}$	20.0				10.0		2.0		
Typical Thermal Resistance <sup>(Note 2)</sup>	$R_{\theta JA}$	55								$^\circ\text{C}/\text{W}$
	$R_{\theta JL}$	25								
Diode junction capacitance <sup>(Note 3)</sup>	$C_J$	30								pF
Operating Junction Temperature	$T_J$	(-55 to +150)								$^\circ\text{C}$
Storage Temperature Range	$T_{STG}$	(-55 to +150)								$^\circ\text{C}$

Notes:

1. Pulse test:300 $\mu\text{s}$  pulse width,1% duty cycle.
2. Unit mounted on P.C.B. with 0.20"×0.20"(5.00mm×5.00mm) copper pads.
3. f=1MHz and applied 4V DC reverse voltage.



SS22L THRU SS220L

VOLTAGE RANGE 20 to 200 Volts  
CURRENT 2.0 Ampere

Ratings and Characteristic Curves ( $T_A=25^\circ\text{C}$  unless otherwise noted)

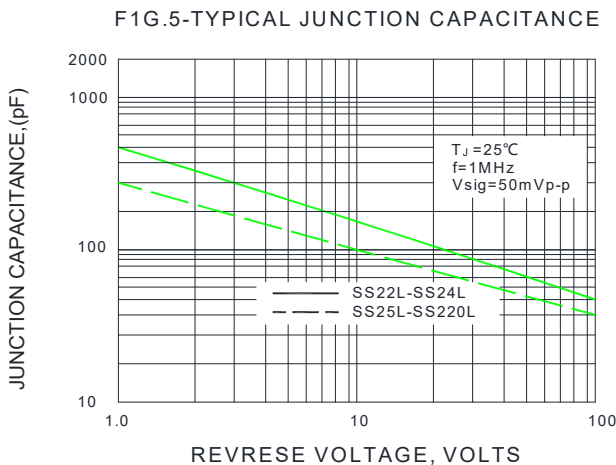
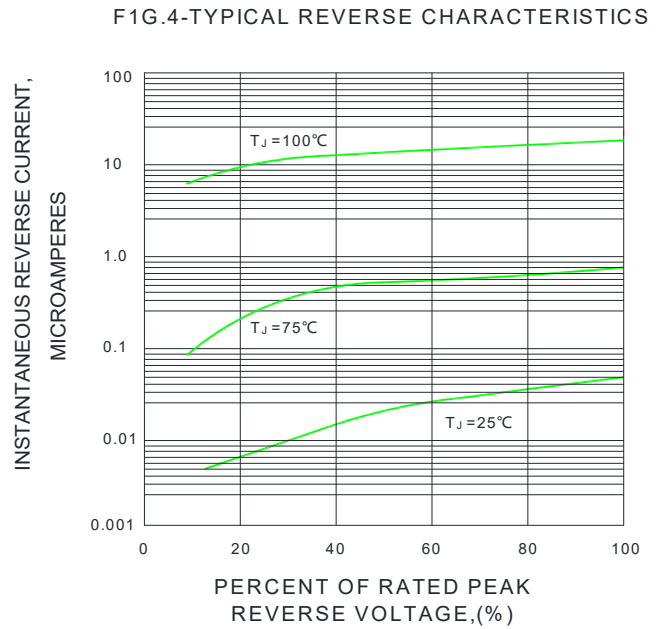
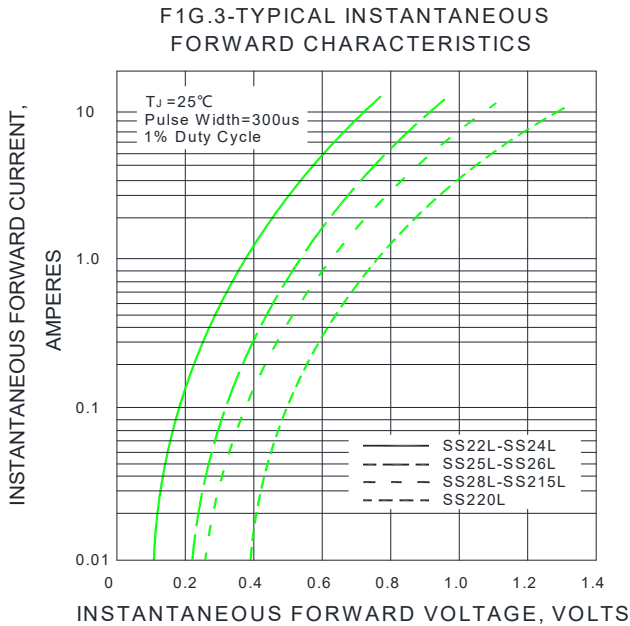
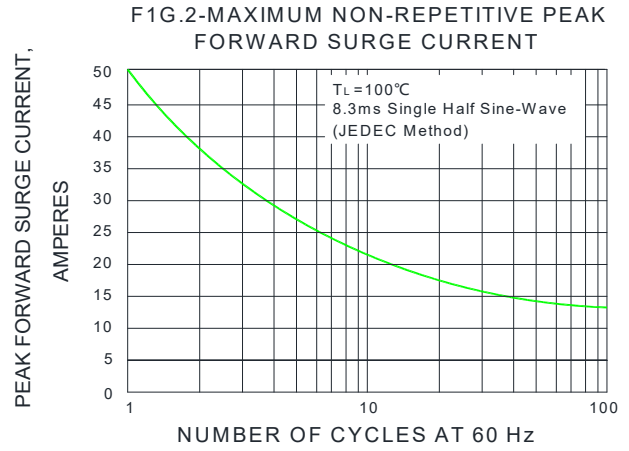
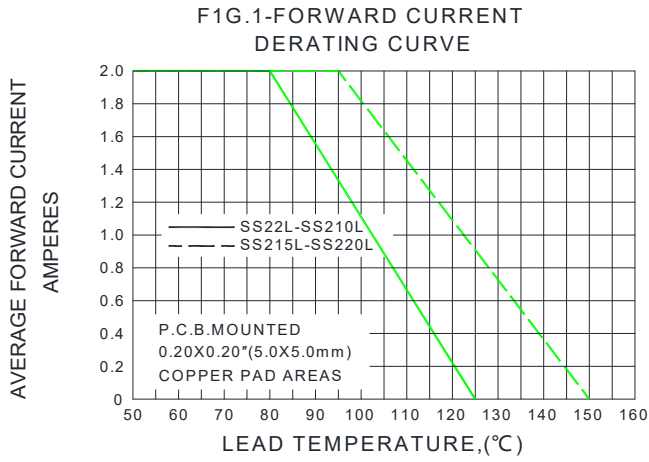



# SURFACE MOUNT SCHOTTKY BARRIER RECTIFIER

SS22L THRU SS220L

VOLTAGE RANGE 20 to 200 Volts  
CURRENT 2.0 Ampere

Package Outline Dimensions in inches (millimeters)

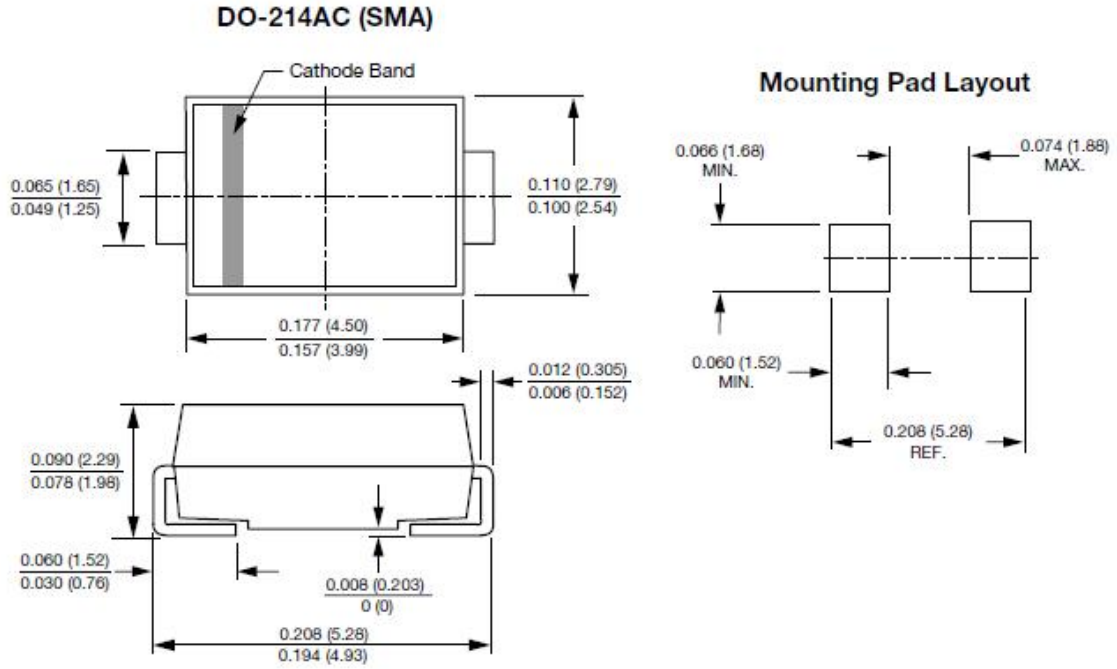



SS22L THRU SS220L

VOLTAGE RANGE

20 to 200 Volts

CURRENT

2.0 Ampere

Package Reel Information

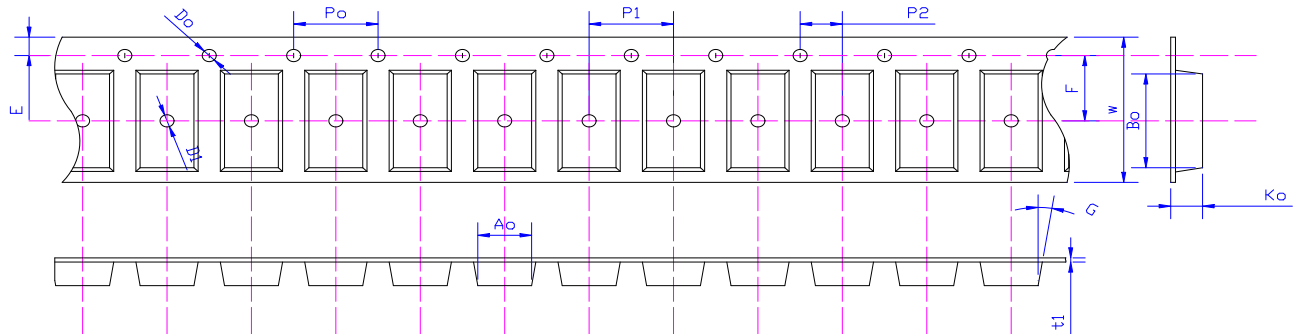

Specifications	Ao	Bo	Ko	Po	W	t1
SMA	2.55±0.10	5.10±0.10	2.36±0.10	4.00±0.1	12.0±0.05	0.23±0.02

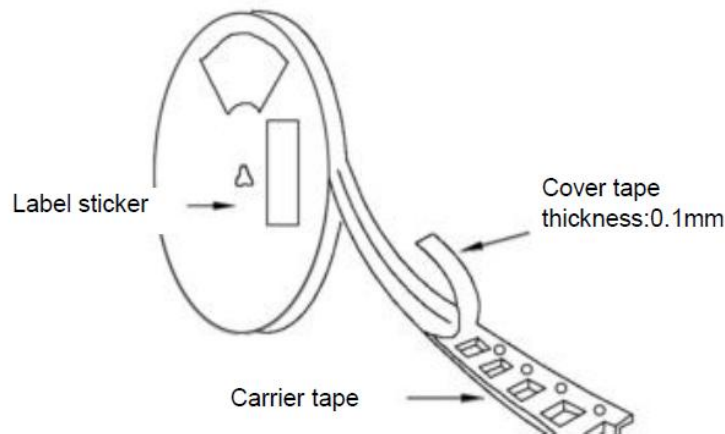

DEVICE TYPE	Tape Width	13"Reel			07"Reel			
		Q'TY/REEL(pcs)	BOX/CARTOO N	Q'TY/CARTON (pcs)	Q'TY/REEL(pcs)	REEL/BOX	BOX/CARTOO N	Q'TY/CARTON (pcs)
SMA	12mm	5000	8	80000	1500	2	16	48000



Reflow Profile

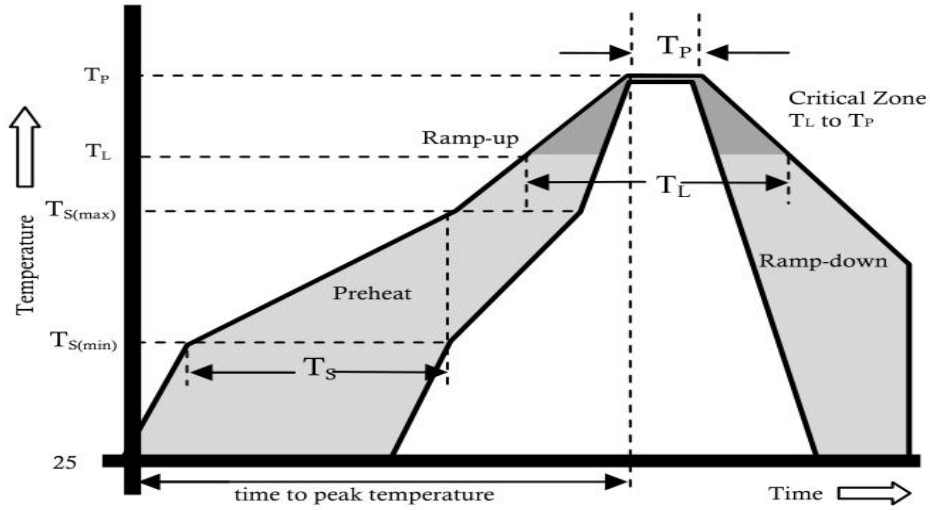

Reflow Condition		Pb-Free Assembly
Pre Heat	Temperature Min.	+150°C
	Temperature Max.	+200°C
	Time(Min to Max)	60-180 secs.
Average ramp up rate(Liquidus Temp( $T_L$ ) to peak)		3°C/sec. Max.
$T_{S(max)}$ to $T_L$ - Ramp-up Rate		3°C/sec. Max.
Reflow	Temperature ( $T_L$ )(Liquidus)	+217°C
	Temperature ( $T_P$ )	60-150 secs.
Peak Temp ( $T_P$ )		+(260+0/-5)°C
Time within 5°C of actual Peak Temp ( $T_P$ )		25 secs.
Ramp-down Rate		6°C/sec. Max.
Time 25°C to peak Temp ( $T_P$ )		8 min. Max.
Do not exceed		+260°C



SS22L THRU SS220L

VOLTAGE RANGE	20 to 200 Volts
CURRENT	2.0 Ampere

## Disclaimer

The information presented in this document is for reference only. Chongqing changjie Electronic Technology Co., Ltd. reserves the right to make changes without notice for the specification of the products displayed herein to improve reliability, function or design or otherwise.

The product listed herein is designed to be used with ordinary electronic equipment or devices, and not designed to be used with equipment or devices which require high level of reliability and the malfunction of which would directly endanger human life (such as medical instruments, transportation equipment, aerospace machinery, nuclear-reactor controllers, fuel controllers and other safety devices), Changjie or anyone on its behalf, assumes no responsibility or liability for any damages resulting from such improper use of sale.

This publication supersedes & replaces all information previously supplied. For additional information, please visit our website [http:// www.czlangjie.com](http://www.czlangjie.com) , or consult your nearest Langjie's sales office for further assistance.