

◆ **Features:**

- ◇ Fast switching speed
开关速度快
- ◇ Low gate charge
低门充电
- ◇ High power and current handling capability
高功率和电流处理能力
- ◇ RoHS compliant
符合 RoHS 标准

◆ **Applications**

- ◇ DC to DC converters
直流到直流转换
- ◇ Synchronous Rectification
同步整流

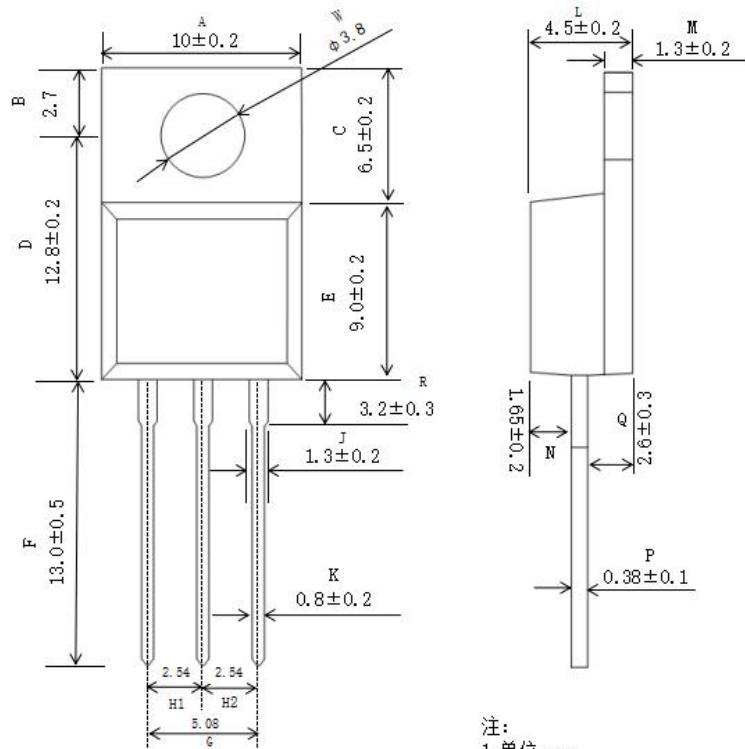
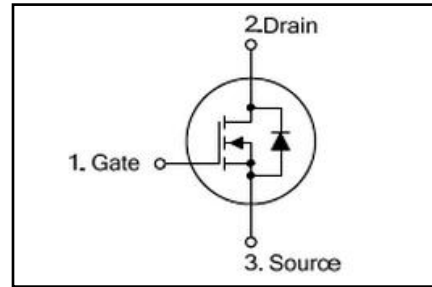
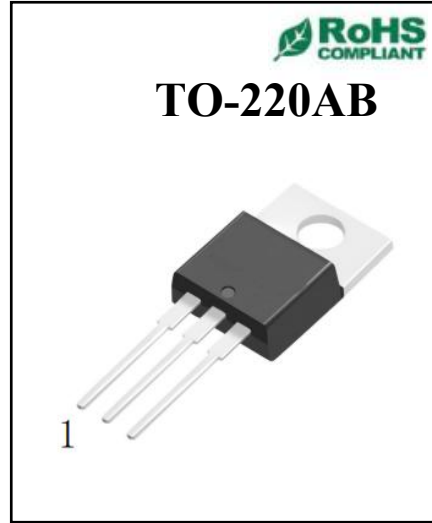

注：
1. 单位：mm
2. 未注公差：±0.2mm
(除非另有说明)



◆ Absolute Maximum Ratings (Tc=25°C)

Symbol	Parameters	Ratings	Unit
V _{DSS}	Drain-Source Voltage 漏源电压	60	V
V _{GS}	Gate-Source Voltage-Continuous 栅源电压	±20	V
I _D	Drain Current-Continuous (Note 2) 漏极持续电流	150	A
I _{DM}	Drain Current-Single Plused (Note 1) 漏极单次脉冲电流	600	A
P _D	Power Dissipation (Note 2) 功率损耗	225	W
T _j	Max.Operating junction temperature 最大结温	150	°C

◆ Electrical characteristics (Tc=25°C unless otherwise noted)

Symbol	Parameters	Min	Typ	Max	Units	Conditions
Static Characteristics						
B _V DSS	Drain-Source Breakdown Voltage 漏极击穿电压 (Note 1)	60	--	--	V	I _D =250μA, V _{GS} =0V
V _{GS(th)}	Gate Threshold Voltage 栅极开启电压	2.0	--	4.0	V	V _{DS} =V _{GS} , I _D =250μA
R _{DS(on)}	Drain-Source On-Resistance 漏源导通电阻	--	2.6	3.0	mΩ	V _{GS} =10V, I _D =20A
I _{GSS}	Gate-Body Leakage Current 栅极漏电流	--	--	±100	nA	V _{GS} =±25V, V _{DS} =0
I _{DSS}	Zero Gate Voltage Drain Current 零栅极电压漏极电流	--	--	1	μA	V _{DS} =60V, V _{GS} =0
g _{fs}	Forward Transconductance 正向跨导	--	15	--	S	V _{DS} =10V, I _D =5A

Switching Characteristics						
$T_{d(on)}$	Turn-On Delay Time 开启延迟时间	--	25	--	ns	$V_{DD}=50V, I_D=10A,$ $R_G=5\Omega$
T_r	Rise Time 上升时间	--	15	--	ns	
$T_{d(off)}$	Turn-Off Delay Time 关闭延迟时间	--	55	--	ns	
T_f	Fall Time 下降时间	--	45	--	ns	
Q_g	Total Gate Charge 栅极总电荷	--	60	--	nC	$V_{DS}=50V,$ $V_{GS}=10V,$ $I_D=75A$
Q_{gs}	Gate-Source Charge 栅源极电荷	--	12	--	nC	
Q_{gd}	Gate-Drain Charge 栅漏极电荷	--	15	--	nC	
Dynamic Characteristics						
C_{iss}	Input Capacitance 输入电容	--	5550	--	pF	$V_{DS}=25V, V_{GS}=0,$ $f=1MHz$
C_{oss}	Output Capacitance 输出电容	--	1350	--	pF	
C_{rss}	Reverse Transfer Capacitance 反向传输电容	--	55	--	pF	
I_S	Continuous Drain-Source Diode Forward Current (Note 2) 二极管导通正向持续电流	--	--	150	A	
V_{SD}	Diode Forward On-Voltage 二极管正向导通电压	--	--	1.3	V	$I_S=30A, V_{GS}=0$
$R_{th(j-c)}$	Thermal Resistance, Junction to Case 结到外壳的热阻	--	--	0.49	$^{\circ}C/W$	

Note 1: Repetitive Rating : Pulse width limited by maximum junction temperature

Note 2: Pulse test: PW ≤ 300us , duty cycle ≤ 2%.