



MP3371

8-Channel, Synchronous, 50V Boost WLED Driver with I²C Interface

DESCRIPTION

The MP3371 is a synchronous boost converter with eight current channels designed to drive WLED arrays for LCD panels in tablets and notebook backlighting applications.

The MP3371 uses peak current control mode and pulse-width modulation (PWM) control to maintain boost converter regulation. The MP3371 employs a standard I²C digital interface to set the operation mode, switching frequency, full-scale current for each channel, sync or non-sync mode, dimming mode and duty, and various protection thresholds.

The MP3371 features high efficiency due to low-headroom voltage for LED regulation and a small on resistance of the switching MOSFET. The synchronous rectifier saves PCB size and total BOM cost.

The MP3371 is available in a QFN-24 (4mmx4mm) package.

FEATURES

- 8 Channels with Max 50mA/Channel
- Synchronous Converter with 50V LS-FET/HS-FET 155m/235mΩ On Resistance
- 3V to 30V Input Voltage Range
- 470mV LED Regulation Voltage at 20mA
- Max 2.5% Current Matching
- 350kHz, 500kHz, 650kHz, 800kHz, 950kHz, or 1.2MHz Selectable Switching Frequency
- A1 Pins for Two I²C Addresses
- 0mA to 50mA Full-Scale LED Current, 8 Bits, 0.196mA/Step
- Selectable Sync or Non-Sync Mode
- Multi-Dimming Operation Mode Including:
 - Analog Dimming through External PWM Input or I²C Interface, 10-Bit Resolution
 - PWM Dimming through External PWM Input or I²C Interface, 14-Bit Resolution
 - Mixed Dimming Mode through External PWM Input or I²C Interface with 6.25%, 12.5%, 25%, or 50% Transfer Point, 14-Bit PWM Duty Resolution
- Linear Smooth Dimming with 2μs, 4μs, 8μs, 16μs, 32μs, 64μs, or 128μs Step-Slope Set
- LED Short/Open, OTP, OCP, Inductor, or Diode Short Protection
 - 2.5V/5V/7.5V/10V LED Short Threshold
 - 24V/31V/37.5V/45V OVP Threshold
 - 1.8A/2.5A Current Limit
- Cascade Function to Share Power Stage
- Available in a QFN-24 (4mmx4mm) Package

APPLICATIONS

- Tablets/Notebooks
- Automotive Displays

All MPS parts are lead-free, halogen-free, and adhere to the RoHS directive. For MPS green status, please visit the MPS website under Quality Assurance. "MPS", the MPS logo, and "Simple, Easy Solutions" are trademarks of Monolithic Power Systems, Inc. or its subsidiaries.

TYPICAL APPLICATION

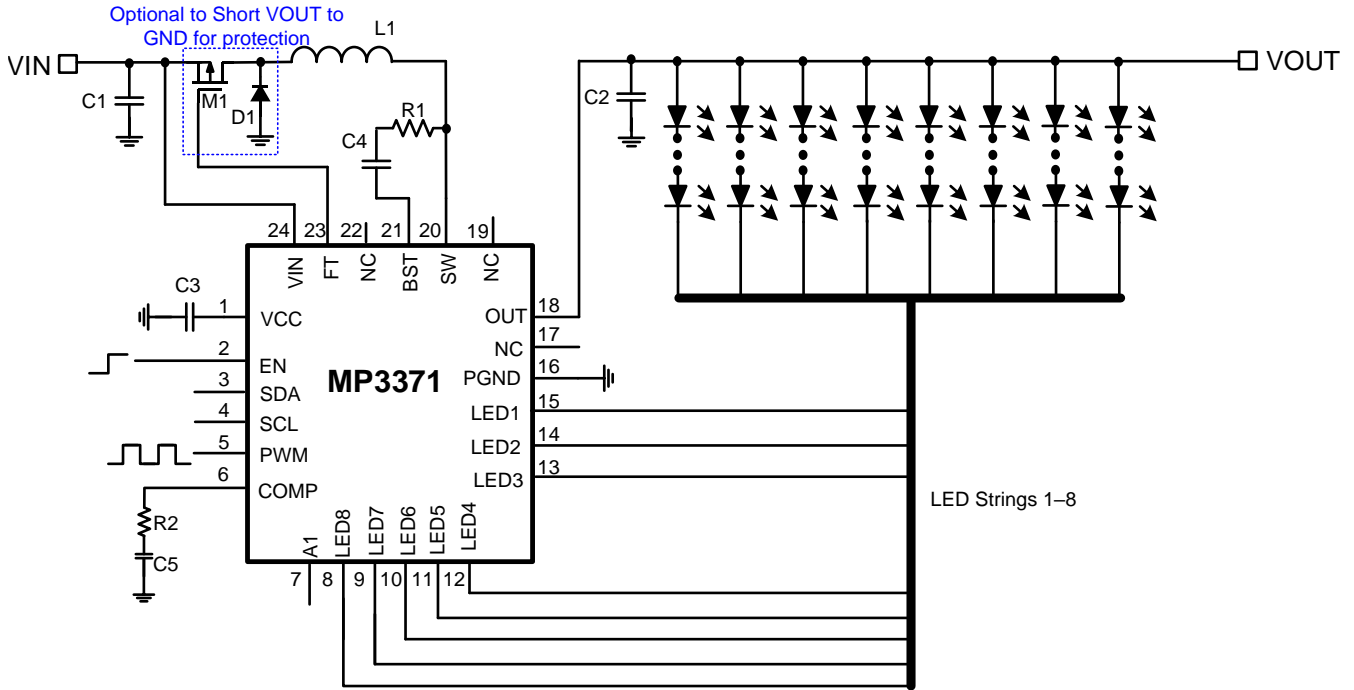

ORDERING INFORMATION

Part Number*	Package	Top Marking	MSL Rating
MP3371GR-xxxx**	QFN-24 (4mmx4mm)	See Below	1

* For Tape & Reel, add suffix -Z (e.g. MP3371GR-xxxx-Z).

** "xxxx" is the configuration code identifier. The first four digits of the suffix (xxxx) can be a hexadecimal value between 0 and F. Work with an MPS FAE to create this unique number for non-default function option. -0000 is the default function value.

TOP MARKING

MPSYWW

MP3371

LLLLLL

MPS: MPS prefix
 Y: Year code
 WW: Week code
 MP3371: Part number
 LLLLLL: Lot number

PACKAGE REFERENCE

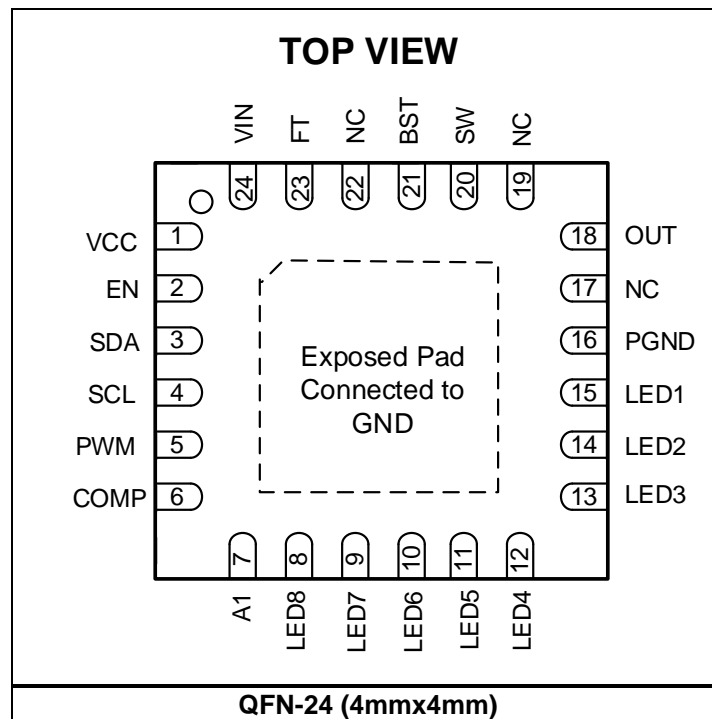

PIN FUNCTIONS

Pin #	Name	Description
1	VCC	5V LDO output. VCC provides power for the internal logic and gate driver. Place a ceramic capacitor as close to VCC as possible to reduce noise.
2	EN	IC enable. Pull EN high to enable the IC; pull EN low to force the IC to enter shutdown mode.
3	SDA	I²C interface data input.
4	SCL	I²C interface clock input.
5	PWM	PWM signal input. Connect PWM to GND if not used.
6	COMP	Compensation Pin. Connect a capacitor and resistor to GND.
7	A1	IC Select. A1 is pulled high internally.
8	LED8	LED current source 8 output. If LED8 is unused, tie it to GND.
9	LED7	LED current source 7 output. If LED7 is unused, tie it to GND.
10	LED6	LED current source 6 output. If LED6 is unused, tie it to GND.
11	LED5	LED current source 5 output. If LED5 is unused, tie it to GND.
12	LED4	LED current source 4 output. If LED4 is unused, tie it to GND.
13	LED3	LED current source 3 output. If LED3 is unused, tie it to GND.
14	LED2	LED current source 2 output. If LED2 is unused, tie it to GND.
15	LED1	LED current source 1 output. If LED1 is unused, tie it to GND.
16	PGND	Power ground.
17, 19, 22	NC	No connection.
18	OUT	Synchronous boost output.
20	SW	Switching node.
21	BST	Bootstrap capacitor node for the high-side MOSFET. Connect a 100nF ceramic capacitor and a 20Ω resistor in series between BST and SW for synchronous mode.
23	FT	Input and output disconnection PMOS gate driver. If there is no fault, FT is pulled low to turn on the external PMOS. Float FT and connect the inductor directly to VIN if the disconnection function is not needed.
24	VIN	IC input power. Place a ceramic capacitor as close to VIN as possible to reduce noise.
	EP	Exposed pad. Connect the EP to GND.

ABSOLUTE MAXIMUM RATINGS ⁽¹⁾

V _{SW} , V _{OUT}	-0.3V to +55V
V _{FT}	V _{IN} - 6V to V _{IN}
V _{LEDX}	-0.3V to +50V
V _{BST}	-0.3V to V _{SW} + 5.5V
V _{IN}	-0.3V to +32V
All other pins	-0.3V to +6.5V
Junction temperature	150°C
Lead temperature	260°C
Continuous power dissipation T _A = 25°C ⁽²⁾	
QFN-24 (4mmx4mm)	2.7W

ESD Rating

Human body model (HBM)	±2000V
Charged device model (CDM).....	±750V

Recommended Operating Conditions ⁽³⁾

Supply voltage (V _{IN})	3V to 30V
Operating junction temp (T _J)	-40°C to +125°C

Thermal Resistance ⁽⁴⁾	θ_{JA}	θ_{JC}
QFN-24 (4mmx4mm).....	46.....	10... °C/W

Notes:

- 1) Exceeding these ratings may damage the device.
- 2) The maximum allowable power dissipation is a function of the maximum junction temperature T_J (MAX), the junction-to-ambient thermal resistance θ_{JA}, and the ambient temperature T_A. The maximum allowable continuous power dissipation at any ambient temperature is calculated by P_D (MAX) = (T_J (MAX) - T_A) / θ_{JA}. Exceeding the maximum allowable power dissipation produces an excessive die temperature, causing the regulator to go into thermal shutdown. Internal thermal shutdown circuitry protects the device from permanent damage.
- 3) The device is not guaranteed to function outside of its operating conditions.
- 4) Measured on JESD51-7, 4-layer PCB.

ELECTRICAL CHARACTERISTICS

V_{IN} = 6V, V_{EN} = 2V, T_A = 25°C, unless otherwise noted.

Parameter	Symbol	Condition	Min	Typ	Max	Units
Operating input voltage	V _{IN}	2.7V has higher VLEDx	2.7		30	V
Quiescent supply current	I _Q	V _{EN} = 3.7V, no switching		3.2	4.5	mA
Shutdown supply current	I _{ST}	V _{EN} = 0V			1	μA
Input UVLO threshold	V _{IN_UVLO}	Rising edge	2.4	2.6	2.8	V
Input UVLO hysteresis				300		mV
LDO output voltage	V _{CC}	V _{EN} = 2V, 6V < V _{IN} < 30V, 0 < I _{VCC} < 10mA	4.85	5	5.15	V
EN on threshold	V _{EN_ON}	V _{EN} rising	1.2			V
EN off threshold	V _{EN_OFF}	V _{EN} falling			0.4	V
EN pull-down resistor	R _{EN}			550		kΩ
A1 low threshold	V _{A_LO}	V _A falling			0.4	V
A1 high threshold	V _{A_HI}	V _A rising	1.2			V
A1 pull-up resistor	R _{P_A}			550		kΩ
Step-Up Converter						
Low-side MOSFET on resistance	R _{DS_LS}		125	155	185	mΩ
High-side MOSFET on resistance	R _{DS_HS}		200	235	270	mΩ
SW leakage current	I _{SW_LK}	V _{SW} = 50V			1	μA
Switching frequency	f _{SW}	FS2:0 bits = 010b	585	650	715	kHz
Maximum duty cycle	D _{MAX}	Sync mode, f _{SW} = 650kHz	91	93.5		%
		Non-sync mode, f _{SW} = 650kHz	92	94		%
SW current limit	I _{SW_LIMIT}	ILIM bit = 1b	2	2.5		A
COMP source current limit	I _{COMP_SOLI}	1V < COMP < 2.9V	75	95	115	μA
COMP sink current limit	I _{COMP_SILI}	1V < COMP < 2.9V	14	19	24	μA
Current Dimming						
PWM input low threshold	V _{PWM_LO}	V _{PWM} falling			0.4	V
PWM input high threshold	V _{PWM_HI}	V _{PWM} rising	1.2			V
PWM pull-down resistor	R _{PWM}			550		kΩ
Mix dimming transfer point		DIMT1:0 bits = 10b		25		%
Current up/down slope	t _{STEP}	TSLP2:0 bits = 011b		16		μs
PWM dimming frequency set by I ² C	f _{PWM}	FPWM3:0 bits = 0111b		22.8		kHz
LED Current Regulator						
LEDx regulation voltage	V _{HD}	I _{LED} = 20mA		470		mV
Current matching ⁽⁵⁾		I _{LED} = 20mA			2.5	%
Full-scale current		ISET7:0 bits = 39h	10.98	11.18	11.42	mA

ELECTRICAL CHARACTERISTICS (continued)
 $V_{IN} = 6V$, $V_{EN} = 2V$, $T_A = 25^{\circ}C$, unless otherwise noted.

Parameter	Symbol	Condition	Min	Typ	Max	Units
Protection						
Over-voltage protection threshold	V_{OVP}	Rising edge, OVP1:0 bits = 11b	45	46.5	49	V
OVP UVLO threshold	V_{OVP_UV}	Step-up converter fails	1.12	1.22	1.32	V
LEDx over-voltage threshold	V_{LEDX_OV}	LEDS1:0 bits = 10b	6.8	7.3	7.8	V
LEDx over-voltage fault timer		$f_{SW} = 1.2MHz$	1.5	1.75	2	ms
LEDx UVLO threshold	V_{LEDX_UV}		55	80	105	mV
Thermal shutdown threshold	T_{ST}	Rising edge		150		$^{\circ}C$
		Hysteresis		20		$^{\circ}C$
FT pull-down current	I_{FT}		51	63	75	μA
FT voltage with respect to V_{IN}	V_{FT-IN}	$V_{IN} = 12V$, $V_{FT-IN} = V_{IN} - V_{FT}$	4.5	5.5	6.5	V
I²C Interface						
Input logic low	V_{IL}				0.4	V
Input logic high	V_{IH}		1.3			V
Output logic low	V_{OL}	$I_{LOAD} = 3mA$			0.4	V
SCL clock frequency	f_{SCL}				1200	kHz
Set-up time for repeated start condition	t_{SU_STA}		160			ns
Hold time for repeated start condition	t_{HD_STA}		160			ns
Low time for SCLH clock	t_{HIGH}		160			ns
High time for SCLH clock	t_{LOW}		60			ns
Data set-up time	t_{SU_DAT}		10			ns
Data hold time	t_{HD_DAT}		0 ⁽⁶⁾		70	ns

ELECTRICAL CHARACTERISTICS (continued)
 $V_{IN} = 6V, V_{EN} = 2V, T_A = 25^\circ C$, unless otherwise noted.

Parameter	Symbol	Condition	Min	Typ	Max	Units
SCLH clock rising time	t_{R_SCL}		10		40	ns
SCLH clock rising time after repeated start and acknowledge bit	t_{R_SCL1}		10		80	ns
SCLH clock falling time	t_{F_CL}		10		40	ns
SDAH data rising time	t_{R_SDA}		10		80	ns
SDAH data falling time	t_{F_SDA}		10		80	ns
Set-up time for stop condition	t_{SU_STO}		160			ns
Capacitance Bus for Each Bus Line	$C_B^{(7)}$				400	pF

Notes:

- 5) Matching is defined as the difference between the maximum and minimum current divided by 2 times the average current.
- 6) A device must provide a data hold time internally to bridge the undefined part between the falling edge V_{IL} and V_{IH} of the SCLH signal. An input circuit with a threshold as low as possible for the falling edge of SCLH signal minimizes the hold time.
- 7) When the bus line load (C_B) is between 100pF and 400pF, timing parameters must be increased linearly.

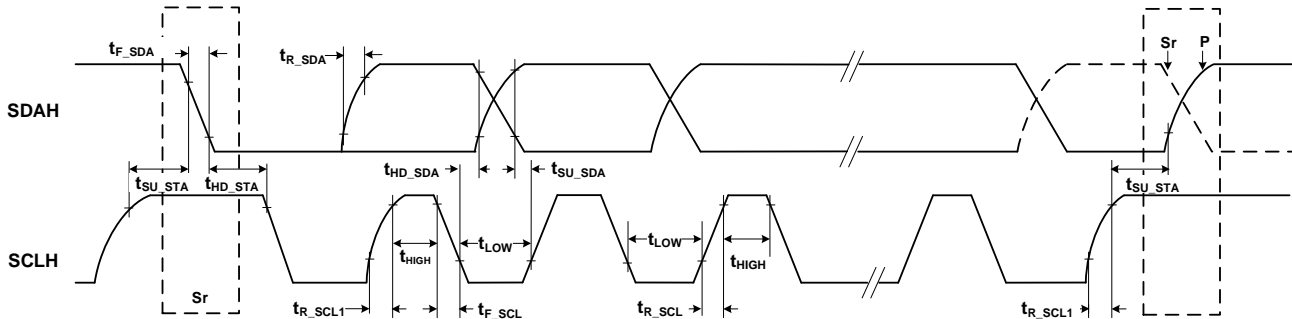
I²C COMPATIBLE INTERFACE TIMING DIAGRAM

Sr: Repeated Start Condition
P: Stop Condition

TYPICAL PERFORMANCE CHARACTERISTICS

V_{IN} = 7V, 13 LEDs in series, 8 strings, 20mA/string, L = 10μH, T_A = 25°C, unless otherwise noted.

Analog Dimming Mode
Steady state

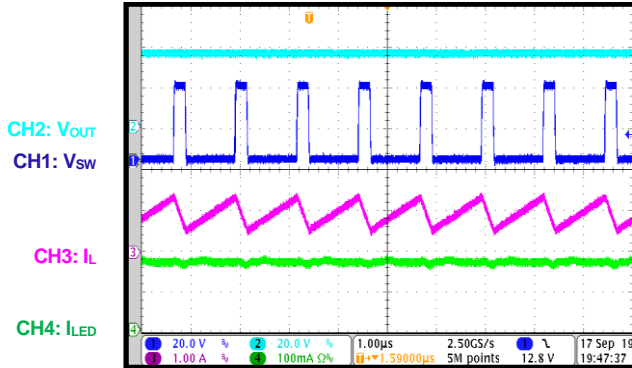

Mix Dimming Mode
With 25% transfer point, D_{PWM} = 25%

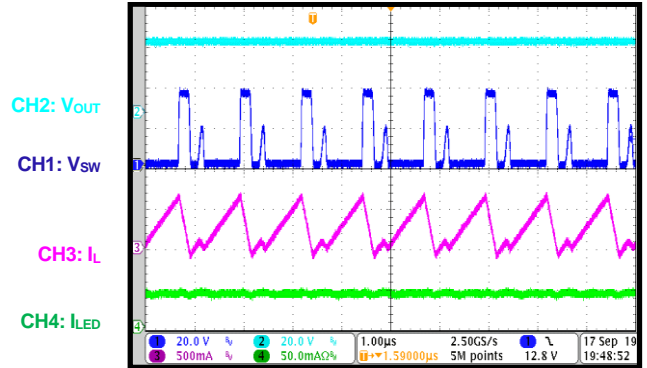

Mix Dimming Mode
With 25% transfer point, D_{PWM} = 24%

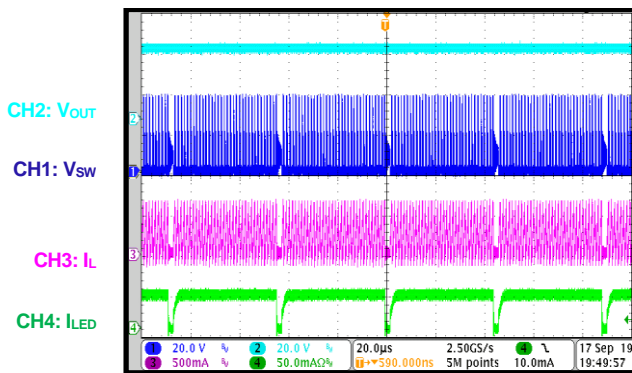

EN Power On

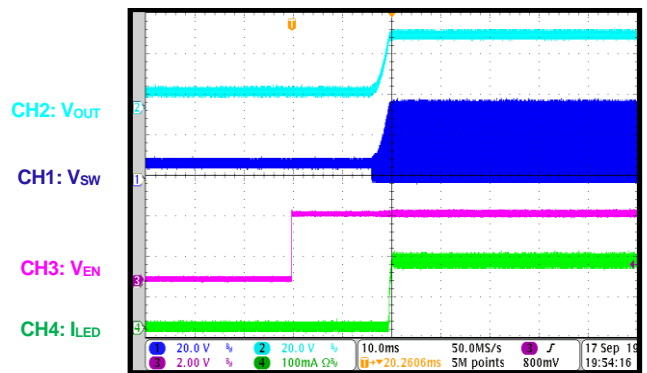

Open LED Protection
V_{OVP} = 45V

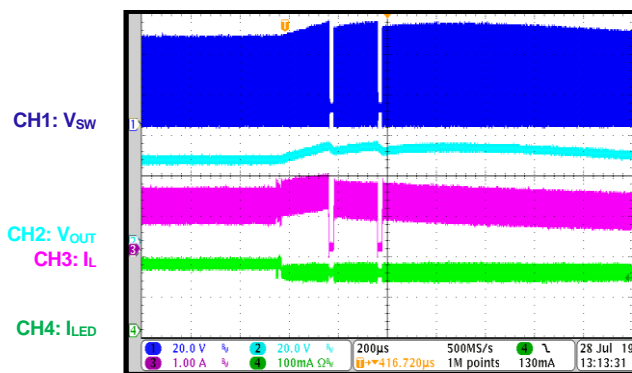

Short LED Protection
Short channel LED1

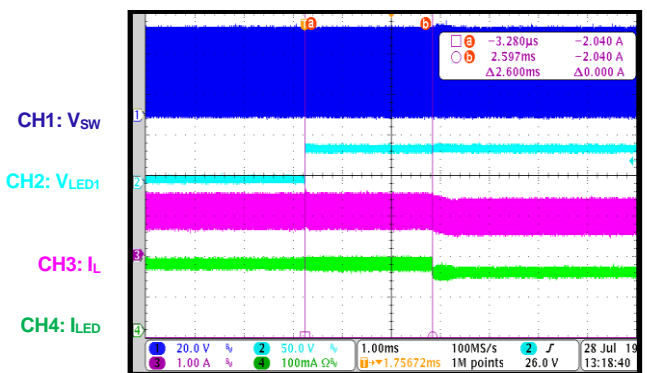

TYPICAL PERFORMANCE CHARACTERISTICS *(continued)*

V_{IN} = 7V, 13 LEDs in series, 8 strings, 20mA/string, L = 10μH, T_A = 25°C, unless otherwise noted.

Thermal Protection
40mA/String

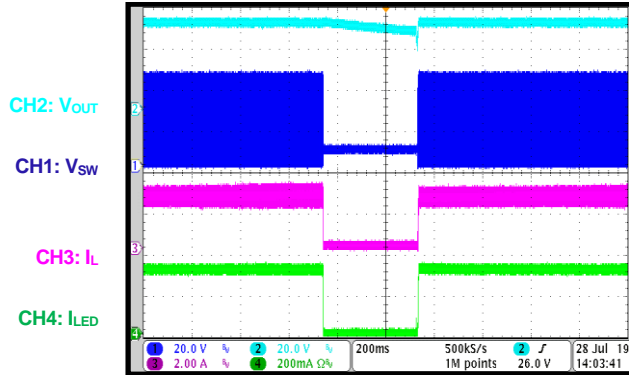

Short Inductor Protection

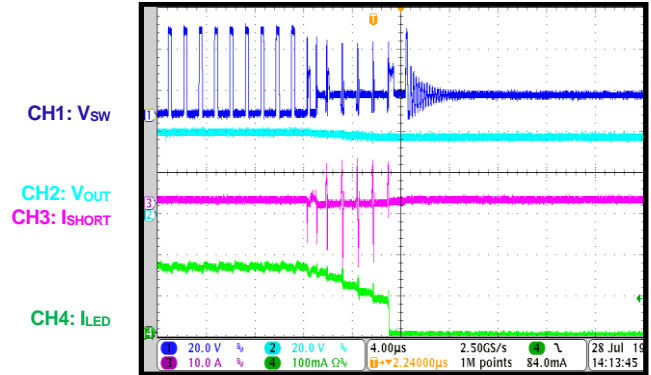

FUNCTIONAL BLOCK DIAGRAM

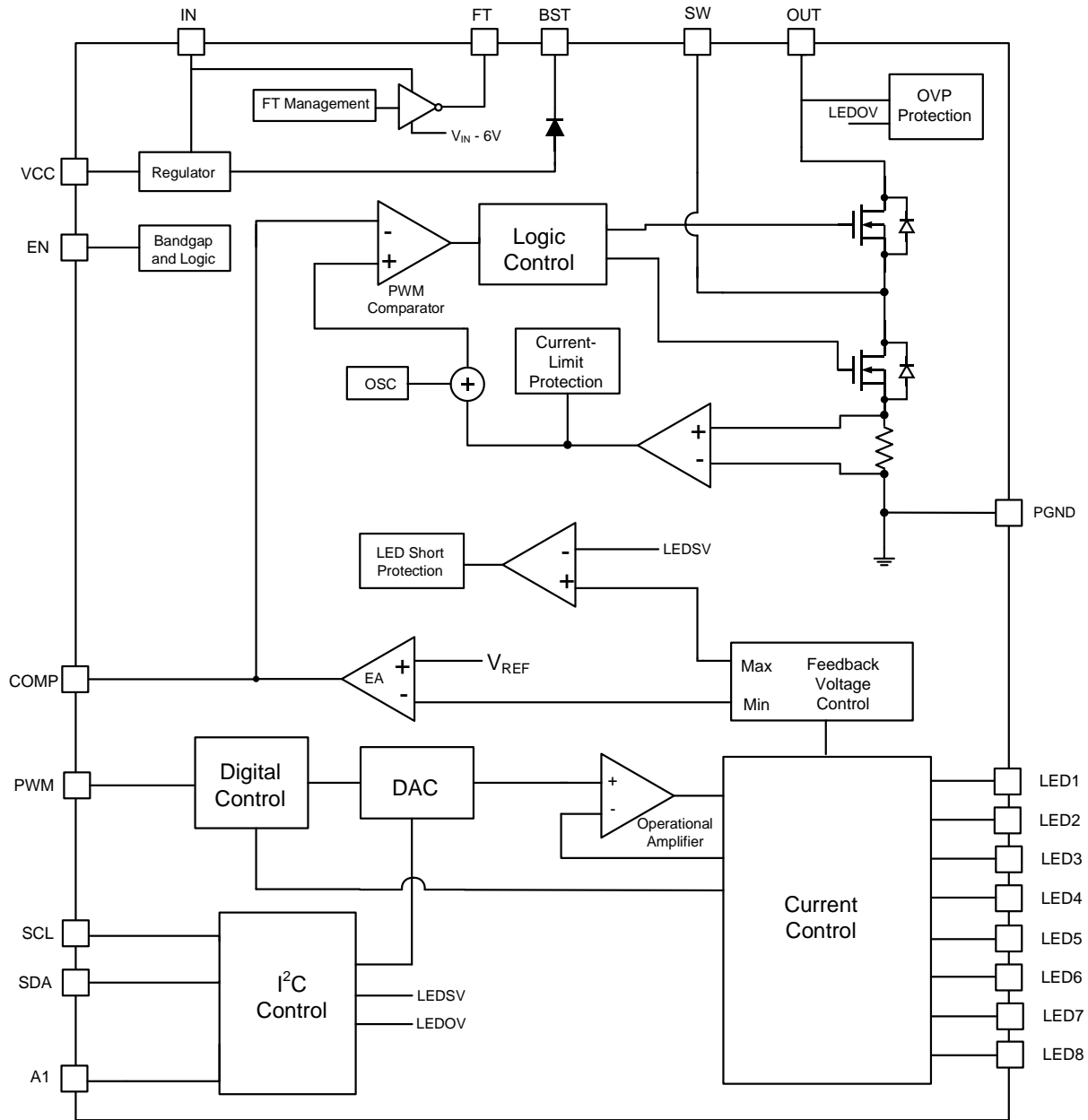

Figure 1: Functional Block Diagram

OPERATION

The MP3371 is a configurable, constant-frequency, peak current mode, step-up converter with up to eight channels of regulated current sources to drive an array of white LEDs. The MP3371 provides a fully integrated solution that saves PCB size and total solution cost. For ease of use, an I²C interface is also integrated into the IC.

Internal 5V Regulator

The MP3371 includes an internal linear regulator (VCC). When V_{IN} exceeds 6V, this regulator outputs a 5V power supply to the internal MOSFET gate driver and internal control circuitry. VCC drops to 0V when the chip shuts down, and then the MP3371 is disabled until VCC exceeds the under-voltage lockout (UVLO) threshold.

Internal Clock

The MP3371 has a fixed 10MHz clock for the internal timer and counter to achieve a high dimming resolution.

Boost Converter Switching Frequency

The boost converter switching frequency can be set by the FS2:0 bits of register 01h. It can be set to 350kHz, 500kHz, 650kHz, 800kHz, 950kHz, 1.2MHz, 1.8MHz, or 2.4MHz.

System Start-Up

When enabled, the MP3371 checks the topology connection. If the MOSFET is being used, the IC first draws current from FT to turn on the input disconnect PMOS. After a 500 μ s delay, the IC then monitors the output voltage (V_{OUT}) to determine if the output is shorted to GND. If V_{OUT} is below 1.22V, the IC is disabled. Lastly, the MP3371 continues to check other safety limits, such as LED open and over-voltage protection (OVP). If all protection tests pass, the IC begins boosting the step-up converter.

The MP3371 can start up regardless of the order in which V_{IN} , PWM, and EN turn on. To achieve a quick response, the recommended power-on sequence is:

1. V_{IN} power on
2. EN power on (wait for 2ms)
3. Send I²C data

4. PWM dimming signal (see Figure 2). When dimming is done only by the I²C interface, the PWM signal can be ignored.

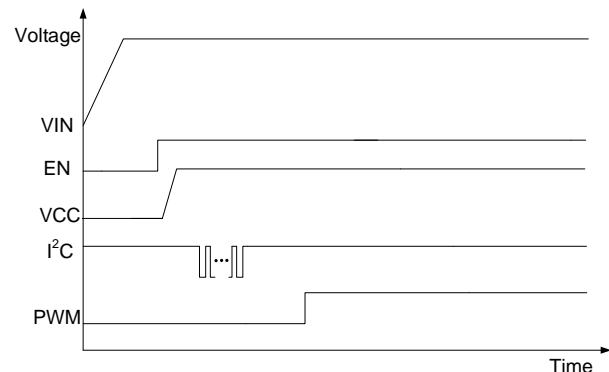

Figure 2: Recommended Power-On Timing

Step-Up Converter

The MP3371 uses peak current mode control to regulate the output voltage. At the beginning of each switching cycle, the internal clock turns on the low-side N-channel MOSFET. In normal operation, the minimum turn-on time is about 100ns.

A stabilizing ramp can be added to the output of the current-sense amplifier. This prevents subharmonic oscillations for duty cycles exceeding 50%. This result is fed into the PWM comparator. When the summed voltage reaches the output voltage of the error amplifier, the low-side MOSFET (LS-FET) turns off.

The output voltage of the error amplifier is an amplified signal of the difference between the reference voltage (V_{REF}) and feedback voltage (V_{FB}). The converter automatically chooses the lowest active LEDx voltage to serve as V_{FB} . This regulates the output voltage to a sufficient level for powering all of the LED arrays.

If V_{FB} drops below V_{REF} , the output of the error amplifier increases. This increases current flowing through the MOSFET and increased power delivered to the output. This forms a closed loop that regulates the output voltage.

Pulse-Skipping Mode

If V_{OUT} is almost equal to V_{IN} under light-load operation, the converter runs in pulse-skip mode, and the MOSFET turns on for a minimum on time.

In pulse-skip mode, the device keeps the power switch off for several switching cycles to prevent the output voltage from rising above the regulated voltage. When the chip stops switching, the output capacitor discharges to the power LED string. The device begins switching until the output voltage needs to be boosted again.

Full-Scale Current Setting

The LED full-scale current can be set by the register ISET7:0 bits (0mA to 50mA, with 0.196mA per step).

Dimming Control

The MP3371 can provide flexible dimming methods based on the dimming mode setting. The dimming options are analog dimming, PWM dimming, and mix dimming mode (see Figure 3, Figure 4, and Figure 5). Each mode can control the LED brightness via the PWM input signal or I²C interface.

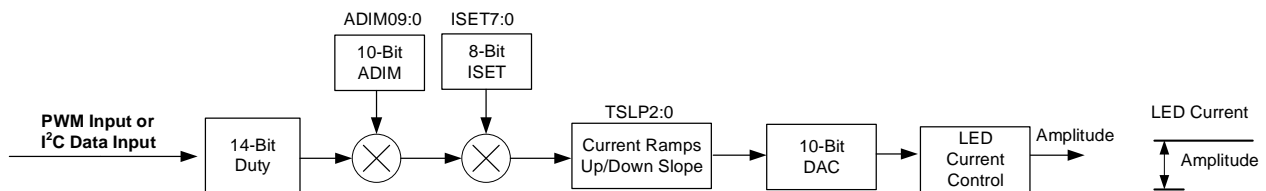

Figure 3: Analog Dimming Mode Flowchart

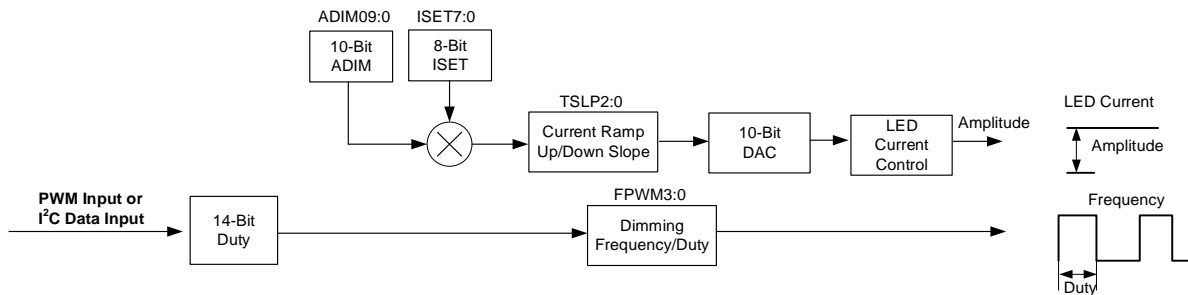

Figure 4: PWM Dimming Mode Flowchart

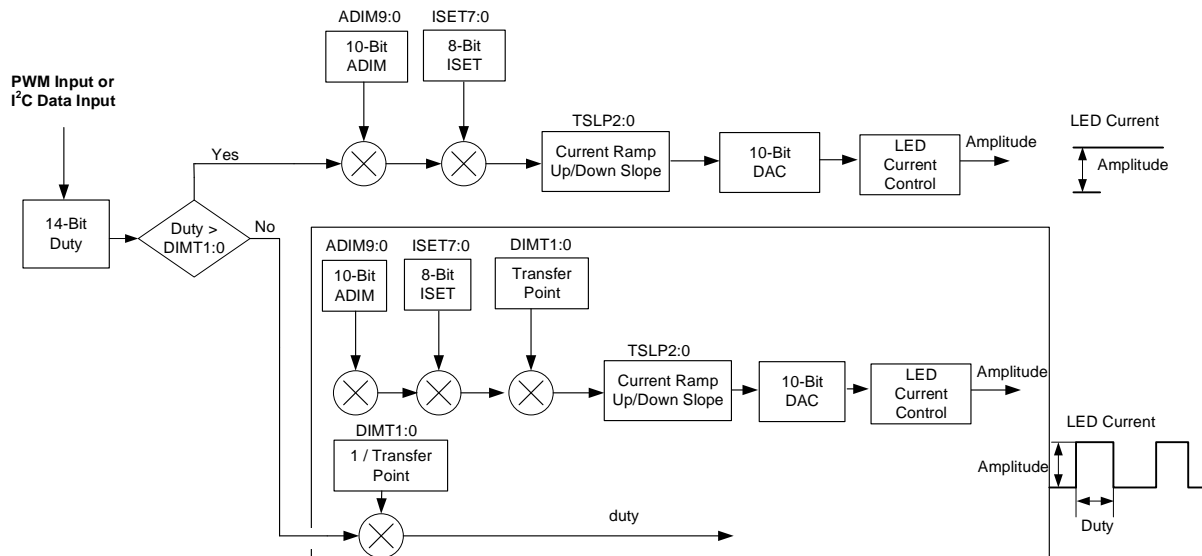

Figure 5: Mix Dimming Mode Flowchart

The MP3371 has six types of dimming modes, described below:

1. **Analog Dimming Mode via PWM Input:** This mode is activated when MOD2:0 = 000b. In analog dimming mode, the LED current amplitude is dependent on the duty cycle of the PWM input signal.

The current amplitude can be changed via the ADIM9:0 10-bit value (see Figure 6).

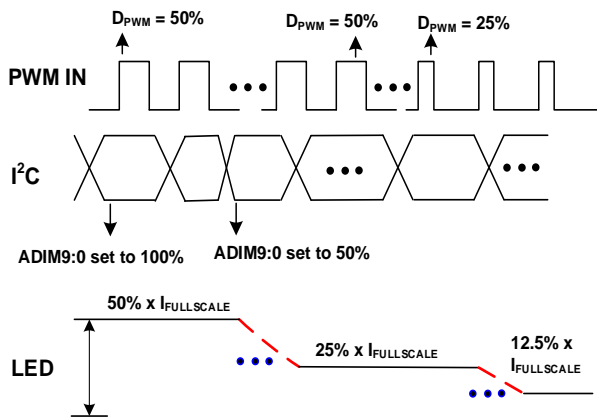

Figure 6: Analog Dimming via PWM Input

2. **Analog Dimming Mode via I²C Interface:** This mode is activated if MOD2:0 = 001b. In analog dimming mode, the LED current amplitude is set by the internal register PWM13:0 bits.

The current amplitude can be changed via the ADIM9:0 10-bit value (see Figure 7).

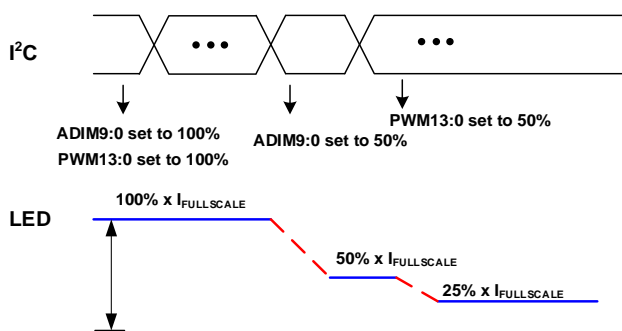

Figure 7: Analog Dimming via I²C Interface

3. **PWM Dimming Mode via PWM Pin:** This mode is activated if MOD2:0 = 010. In this mode, the LED current is chopped as a PWM waveform. The PWM frequency is set by the internal FPWM3:0 bits. The duty cycle is dependent on the calculated value from the PWM pin signal. The current amplitude can be changed by via the ADIM9:0 10-bit value (see Figure 8).

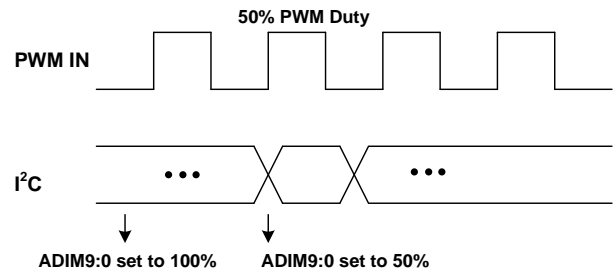

Figure 8: PWM Dimming via PWM Input

4. **PWM Dimming Mode via PWM Register:** This mode is activated if MOD2:0 = 011. In this mode, the LED current is chopped as a PWM waveform. The PWM frequency is set by the internal FPWM0:3 bits, and the duty cycle is set by the PWM0:13 bits. The current amplitude can be changed by the internal ADIM9:0 10-bit value (see Figure 9).

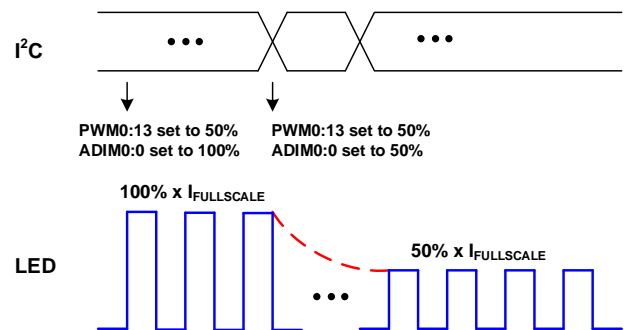

Figure 9: PWM Dimming via I²C Interface

5. **Mix Dimming Mode from PWM Input:** This mode is activated if MOD2:0 = 100b. If the duty cycle from PWM exceeds the threshold set by the DIMIT1:0 bits during mix dimming mode, the IC works in analog dimming mode.

The LED current amplitude follows the input duty. If the duty cycle from the PWM input is below the threshold set by the DIMIT1:0 bits, the IC works in PWM dimming mode, and the PWM LED current frequency is set by the FPWM3:0 bits. The PWM LED current duty is extended according to the selected transfer point.

For example, if the transfer point is 25%, then the PWM LED current duty = PWM input duty x 1 / (25%). The PWM LED current amplitude is

fixed to the value at the transfer point set by DIMT1:0.

The current amplitude can be changed by the register ADIM9:0 10-bit value (see Figure 10).

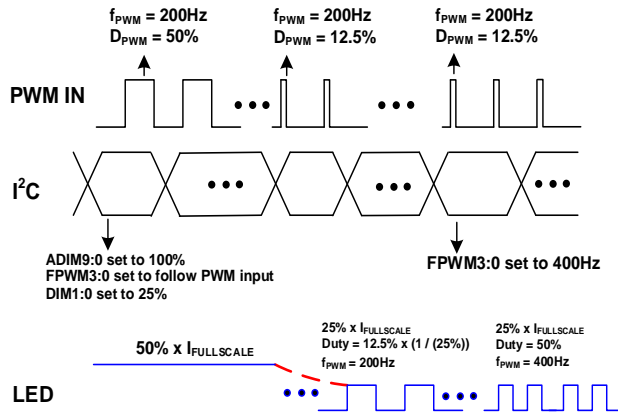

Figure 10: Mix Dimming from PWM Input

6. Mix Dimming Mode from I²C Interface: This mode is activated if MOD2:0 = 101b. If the duty cycle from the internal PWM13:0 bits exceeds the threshold set by the DIMT1:0 bits during mix dimming mode, the IC works in analog dimming mode.

The LED current amplitude follows the PWM13:0 bits. If the duty cycle from the register PWM13:0 bits is below the threshold set by the DIMT1:0 bits, the IC works in PWM dimming mode, and the PWM frequency is set by the FPWM3:0 bits. The PWM LED current duty is extended according to the transfer point selected.

For example, if the transfer point is 25%, then the PWM LED current duty = duty set by PWM13:0 bits x 1 / (25%). The PWM LED current amplitude is fixed to the value at the transfer point duty set by DIMT1:0.

The current amplitude can be changed by the ADIM9:0 10-bit value (see Figure 11).

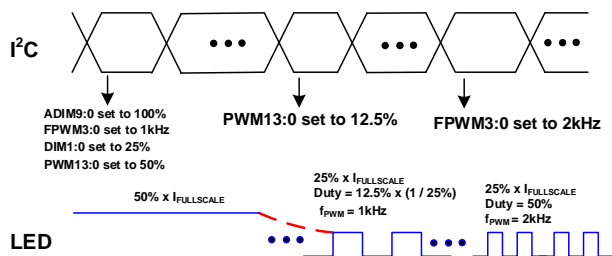

Figure 11: Mix Dimming via I²C Interface

Linear Dimming for Fade-In/Out

The MP3371 provides linear current rising up or down. The LED current ramps up or down linearly. The current ramp-up or ramp-down slope can be set from 2μs to 128μs using the TSLP2:0 bits (0.049mA for each step).

Deep Dimming Ratio

To provide enough output energy for the LED load when the PWM LED current duty is very small, the MP3371 provides at least four switching cycles to guarantee sufficient output voltage before the next PWM LED current on duty cycle. This helps the device achieve a wide dimming ratio range in PWM dimming mode. The dimming ratio is dependent on the LED current dimming frequency and LED current source turn-on/off times. The lower the PWM dimming frequency, the higher the dimming ratio.

It is recommended that the minimum on time for the LED string be longer than 1.5μs to achieve good dimming. The dimming ratio can reach 100:1 at 22.32kHz in mix dimming mode.

Unused LED Channel Setting

The MP3371 can detect an unused LED string automatically and remove it from the control loop during start-up by either connecting the unused LEDx pin to GND, or by setting the corresponding CHEN7:0 bit to 0.

Synchronous Rectifier

To save cost and reduce PCB size, the MP3371 works in synchronous rectifier mode by default. A 100nF ceramic capacitor and a 20Ω resistor in series between BST and SW is the optimal BST supply choice for the synchronous converter.

In some cases, such as extremely high switching frequency and high output power applications, it is recommended to use an external rectifier for better thermal and efficiency. To disable the internal synchronous rectifier, set the register SYNC bit to 0.

Open-String Protection

Open-string protection is achieved by detecting the voltage on the OUT and LED1:8 pins. If one string is open during operation, the respective LEDx pin is pulled low to ground, and the IC continues charging the output voltage until it reaches the over-voltage protection (OVP) threshold (set by the OVP1:0 bits).

If OVP is triggered, the chip stops switching and marks off the fault string that has an LEDx pin voltage below 80mV. Once marked, the remaining LED strings force the output voltage back to normal regulation. The string with the largest voltage drop determines the output regulation value.

Short-String Protection

The MP3371 monitors the LEDx pin voltages to determine whether a short-string fault has occurred. If one or more strings are shorted, the remaining LEDx pins tolerate high voltage stress. If an LEDx pin voltage exceeds the protection threshold (configured via the LED_S1:0 bits), an internal counter starts. If this fault condition lasts for 1.8ms ($f_{sw} = 1.2\text{MHz}$, 100% duty cycle), the fault string is marked off and disabled. Once a string is marked off, it is disconnected from the output voltage loop until the part restarts.

If all the active LEDx pins are shorted for 30ms (100% duty cycle), the MP3371 shuts down the step-up converter until the power is restarted (VIN supply switches on from off) or EN is toggled (EN switches on from off).

Cycle-by-Cycle Current Limit

To prevent the external components from exceeding the current stress rating, the IC uses cycle-by-cycle current-limit protection. The limit value can be selected by the ILIM bit. When the current exceeds the current-limit value, the IC stops switching until the next clock cycle begins.

Latch-Off Current Limit Protection

To prevent damage from a large current rating (such as an inductor or diode short to GND), the MP3371 uses latch-off current-limit protection when the current flowing through the LS-FET reaches the threshold (3.5A) within 200ns and lasts for five switching cycles.

Thermal Protection

To prevent the IC from operating at exceedingly high temperatures, thermal shutdown is implemented by detecting the silicon die temperature. When the die temperature exceeds the upper threshold (T_{ST}), the IC shuts down. It resumes normal operation when the die temperature drops below the lower threshold. Typically, the hysteresis value is 20°C.

I²C Interface Register Description

The Read/Write (R/W) register is ready after EN has been ready for 2ms.

I²C Chip Address

The 7-bit MSB device address is 0x28/0x29. After start-up, the I²C-compatible master sends a 7-bit address followed by an 8th read (1) or write (0) bit.

The following bit indicates the register address to or from which the data is written or read, respectively. A1 can program the IC address. Therefore, two MP3371 chips can share the same I²C interface.

0	1	0	1	0	0	A1	R/W
---	---	---	---	---	---	----	-----

I²C Compatible Device Address

REGISTER MAP

Add	D15	D14	D13	D12	D11	D10	D9	D8
00H	ISET7	ISET6	ISET5	ISET4	ISET3	ISET2	ISET1	ISET0
Add	D7	D6	D5	D4	D3	D2	D1	D0
00H	CHEN7	CHEN6	CHEN5	CHEN4	CHEN3	CHEN2	CHEN1	CHEN0

Add	D15	D14	D13	D12	D11	D10	D9	D8
01H	RESERVED	RESERVED	RESERVED	RESERVED	RESERVED	RESERVED	OVP1	OVP0
Add	D7	D6	D5	D4	D3	D2	D1	D0
01H	SYNC	MOD2	MOD1	MOD0	ILIM	FS2	FS1	FS0

Add	D15	D14	D13	D12	D11	D10	D9	D8
02H	RESERVED	RESERVED	RESERVED	RESERVED	RESERVED	RESERVED	ADIM9	ADIM8
Add	D7	D6	D5	D4	D3	D2	D1	D0
02H	ADIM7	ADIM6	ADIM5	ADIM4	ADIM3	ADIM2	ADIM1	ADIM0

Add	D15	D14	D13	D12	D11	D10	D9	D8
03H	RESERVED	RESERVED	RESERVED	RESERVED	RESERVED	TSLP2	TSLP1	TSLP0
Add	D7	D6	D5	D4	D3	D2	D1	D0
03H	LEDS1	LEDS0	FPWM3	FPWM2	FPWM1	FPWM0	DIMT1	DIMT0

Add	D15	D14	D13	D12	D11	D10	D9	D8
04H	RESERVED	RESERVED	PWM13	PWM12	PWM11	PWM10	PWM9	PWM8
Add	D7	D6	D5	D4	D3	D2	D1	D0
04H	PWM7	PWM6	PWM5	PWM4	PWM3	PWM2	PWM1	PWM0

Add	D15	D14	D13	D12	D11	D10	D9	D8
05H	ID7	ID6	ID5	ID4	ID3	ID2	ID1	ID0
Add	D7	D6	D5	D4	D3	D2	D1	D0
05H	RESERVED	RESERVED	RESERVED	FT_OTP	FT_OCP	FT_OVP	FT_LEDO	FT_LEDS

Note:

8) All write registers have one-time configurability.

Table 1: Full-Scale and Channel Enable Register

Addr: 0x00				
Bits	Bit Name	Access	Default	Description
15:8	IS _{ET} 7:0	R/W	0x62	LED current full-scale current bits. These bits set the maximum current for each channel. 0x00: 0mA 0x62: 19.2mA ... 0x66: 20mA ... 0xFF: 50mA, 0.196mA/step
7:0	CH _{EN} 7:0	R/W	0x3F	LED current source enable bits. The CH _{EN} 0:7 bits control the internal LED current sources. CH _{EN} 0: Enable bit for LED current source 1. 1: Enable 0: Disable CH _{EN} 1: Enable bit for LED current source 2. 1: Enable 0: Disable CH _{EN} 2: Enable bit for LED current source 3. 1: Enable 0: Disable CH _{EN} 3: Enable bit for LED current source 4. 1: Enable 0: Disable CH _{EN} 4: Enable bit for LED current source 5. 1: Enable 0: Disable CH _{EN} 5: Enable bit for LED current source 6. 1: Enable 0: Disable CH _{EN} 6: Enable bit for LED current source 7. 1: Enable 0: Disable CH _{EN} 7: Enable bit for LED current source 8. 1: Enable 0: Disable

Table 2: Dimming Mode and Parameter Set Register

Addr: 0x01				
Bits	Bit Name	Access	Default	Description
15:10	RESERVED	R	RESERVED	Reserved.
9:8	OVP1:0	R/W	10b	Output over-voltage protection (OVP) threshold bits. 00: 24V 01: 31V 10: 37.5V 11: 45V

7	SYNC	R/W	1b	Boost converter rectifier operation mode bit. 0: IC works in non-synchronous mode 1: IC works in synchronous mode
6:4	MOD2:0	R/W	100b	LED current dimming mode bits. 000: The part works in analog dimming mode through the external PWM input signal. The LED current amplitude changes with the input PWM duty 001: The part works in analog dimming mode through the I ² C interface. The LED current amplitude changes with the PWM13:0 bits 010: The part works in internal PWM dimming mode, and the signal from the PWM pin determines the LED current duty cycle 011: The part works in internal PWM dimming mode and the value from bits PWM0:13 determine the LED current duty cycle 100: The IC works in mix dimming mode through the external PWM input signal. If the input PWM duty cycle exceeds the transfer point, the IC works in analog dimming mode. Otherwise, the IC works in PWM dimming mode. The DIMT1:0 bits determines the transfer point of mix dimming mode 101: The IC works in mix dimming mode through the I ² C interface. If the duty cycle set by the PWM13:0 bit exceeds the transfer point, the IC works in analog dimming mode. Otherwise, the IC works in PWM dimming mode. The DIMT1:0 bits determines the transfer point for mix dimming mode
3	ILIM	R/W	1b	Inductor cycle-by-cycle current limit bit. 0: 1.8A current limit 1: 2.5A current limit
2:0	FS2:0	R/W	010b	Boost converter switching frequency bits. 000: 350kHz 001: 500kHz 010: 650kHz 011: 800kHz 100: 950kHz 101: 1.2MHz 110: 1.8MHz 111: 2.4MHz

Table 3: Analog Dimming Register

Addr: 0x02				
Bits	Bit Name	Access	Default	Description
15:10	RESERVED	R	RESERVED	Reserved.
9:0	ADIM9:0	R/W	0x3FF	Analog dimming bits. Control the LED current amplitude in any dimming mode. 0x000: 0% 0x001: 0.098% ... 0x3FF: 100%, 0.098% per step

Table 4: Slope and PWM Dimming Frequency Register

Addr: 0x03				
Bits	Bit Name	Access	Default	Description
15:11	RESERVED	R	RESERVED	Reserved.
10:8	TSLP2:0	R/W	011b	LED current ramp-up/down slope bit. 000: 2µs per step 001: 4µs per step 010: 8µs per step 011: 16µs per step 100: 32µs per step 101: 64µs per step 110: 128µs per step 111: RESERVED
7:6	LEDS1:0	R/W	01b	LED short protection threshold bits. 00: 2.5V 01: 5V 10: 7.5V 11: 10V
5:2	FPWM3:0	R/W	1010b	LED current dimming frequency bits when the device is in PWM dimming or mix dimming mode. 0000: Follow external PWM dimming signal (direct PWM dimming) 0001: 200Hz 0010~0101: Reserved 0110: 26.04kHz 0111: 22.32kHz 1000: 19.53kHz 1001: 17.36kHz 1010: 15.63kHz 1011: 14.20kHz 1100: 13.02kHz 1101: 12.02kHz 1110: 11.16kHz 1111: 10.42kHz
1:0	DIMT1:0	R/W	10b	Transfer point bits in mix dimming mode. If the dimming duty exceeds the threshold, the IC works in analog dimming mode. Otherwise, the IC works in PWM dimming mode. 00: 6.25% 01: 12.5% 10: 25% 11: 50%

Table 5: Internal I²C Dimming Register

Addr: 0x04				
Bits	Bit Name	Access	Default	Description
15:14	RESERVED	R	RESERVED	Reserved.
13:0	PWM13:0	R/W	0x0000	LED current dimming duty setting bit via the I ² C interface. This controls the LED current dimming duty when the MOD2:0 bit is set to 001b or 101b. 0x0000: 0% 0x0001: 0.006% ... 0x3FFF: 100%, 0.006% per step

Table 6: ID and Fault Register

Addr: 0x05				
Bits	Bit Name	Access	Default	Description
15:8	ID7:0	R	00010001b	Device ID bits.
7:5	RESERVED	R	RESERVED	Reserved.
4	FT_OTP	R	0b	Over-temperature protection (OTP) fault indication bit. The fault status latches off after the bit is read and reset to 0. 0: No OTP fault has occurred 1: OTP fault has occurred
3	FT_OCP	R	0b	Over-current protection (OCP) fault indication bit. The fault status latches off after the bit is read and reset to 0. 0: No OCP fault has occurred 1: OCP fault has occurred
2	FT_OVP	R	0b	Over-voltage protection (OVP) fault indication bit. The fault status latches off after the bit is read and reset to 0. 0: No OVP fault has occurred 1: OVP fault has occurred
1	FT_LEDO	R	0b	LED current source open fault indication bit. The fault status latches off after the bit is read and reset to 0. 0: No LED current source open fault has occurred 1: LED current source open fault has occurred
0	FT_LEDS	R	0b	LED short fault indication bit. The fault status latches off after the bit is read and reset to 0. 0: No LED short fault has occurred 1: LED short fault has occurred

APPLICATION INFORMATION

Selecting the Switching Frequency

The switching frequency of the step-up converter is set by register bits FS2:0 (see Table 2 on page 18).

Setting the LED Current

The LED string full-scale current is set by the register ISET7:0 bits (from 0mA to 50mA with 0.196mA per step).

Selecting the Input Capacitor

The input capacitor reduces the surge current drawn from the input supply, as well as the switching noise from the device. The input capacitor impedance at the switching frequency should be less than the input source impedance to prevent the high-frequency switching current from passing through to the input. Ceramic capacitors with X5R or X7R dielectrics are recommended for their low ESR and small temperature coefficients. For most applications, a 4.7µF ceramic capacitor is sufficient.

Selecting the Inductor

The MP3371 requires an inductor to supply a higher V_{OUT} while being driven by V_{IN}. A larger-value inductor results in lower ripple current and peak inductor current, and reduced stress on the internal N-channel MOSFET. However, a larger-value inductor also has a larger physical size, higher series resistance, and lower saturation current.

Choose an inductor that does not saturate under the worst-case load conditions. Select the minimum inductor value to ensure that the boost converter works in continuous conduction mode with high efficiency and good EMI performance.

Calculate the required inductance value using Equation (1):

$$L \geq \frac{\eta \times V_{OUT} \times D \times (1-D)^2}{2 \times f_{SW} \times I_{LOAD}} \quad (1)$$

Where V_{OUT} is the output voltage, D is the switching duty, f_{SW} is the switching frequency, I_{LOAD} is the LED load current, and η is the efficiency.

D can be calculated with Equation (2):

$$D = 1 - \frac{V_{IN}}{V_{OUT}} \quad (2)$$

Where V_{IN} is the input voltage.

For a given inductor value in most applications, the inductor DC current rating should be at least 40% greater than the maximum input peak inductor current. The inductor's DC resistance should be as small as possible to improve efficiency.

Selecting the Output Capacitor

The output capacitor keeps the output voltage ripple small and ensures feedback loop stability. The output capacitor impedance must be low at the switching frequency. Ceramic capacitors with X7R dielectrics are recommended for their low ESR. For most applications, a 2.2µF ceramic capacitor is sufficient.

Setting the Over-Voltage Protection (OVP)

The output over-voltage protection (OVP) threshold is set by the register OVP1:0 bits (see Table 2 on page 18).

PCB Layout Guidelines

Careful attention must be given to the PCB layout and component placement. Efficient PCB layout on the high-frequency switching path is critical to prevent noise and electromagnetic interference problems. For the best results, follow the guidelines below:

1. Keep the loop of SW to PGND, the external diode (if used), and the output capacitor as short as possible, since it flows with a high-frequency pulse current.
2. Place a ceramic capacitor close to the input and VCC, since they are susceptible to noise.

TYPICAL APPLICATION CIRCUIT

MP1: Optional for short VOUT to GND protection

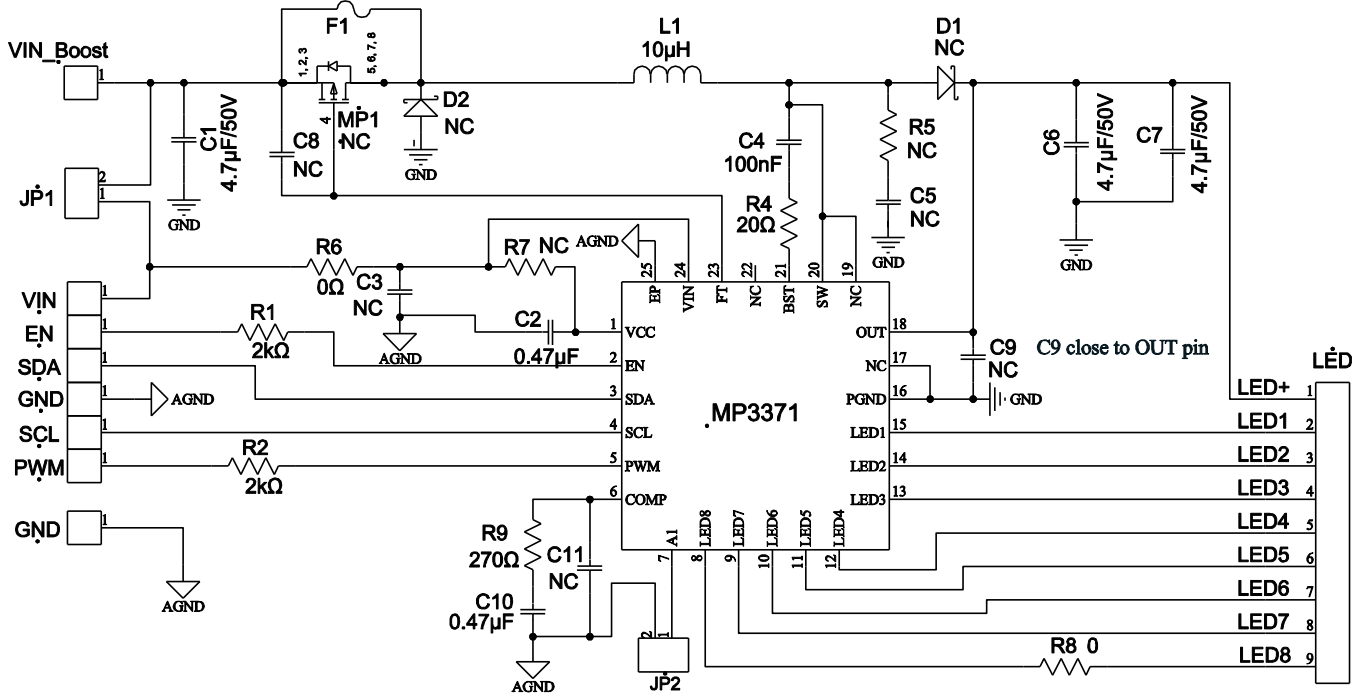
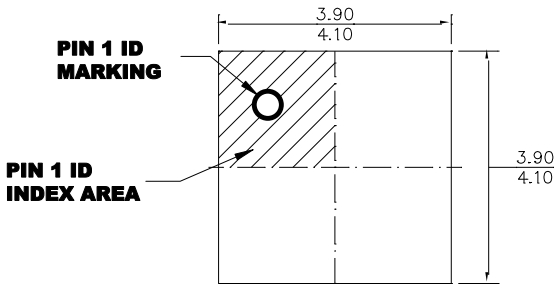

Figure 12: Typical Application Circuit

PACKAGE INFORMATION

QFN-24 (4mmx4mm)



TOP VIEW

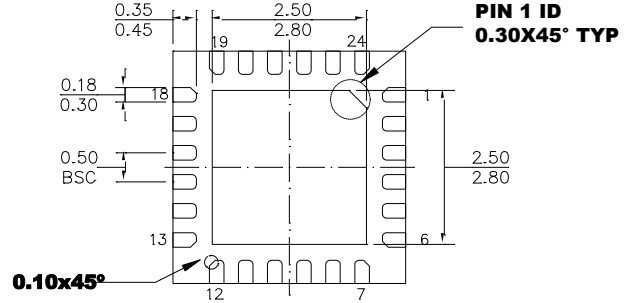

BOTTOM VIEW

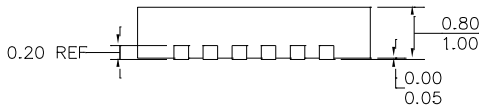

SIDE VIEW

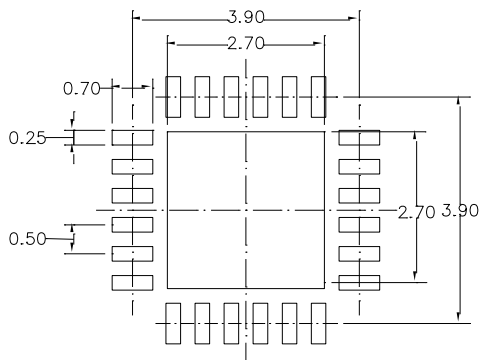

RECOMMENDED LAND PATTERN

NOTE:

- 1) ALL DIMENSIONS ARE IN MILLIMETERS.
- 2) EXPOSED PADDLE SIZE DOES NOT INCLUDE MOLD FLASH.
- 3) LEAD COPLANARITY SHALL BE 0.08 MILLIMETERS MAX.
- 4) JEDEC REFERENCE IS MO-220
- 5) DRAWING IS NOT TO SCALE.

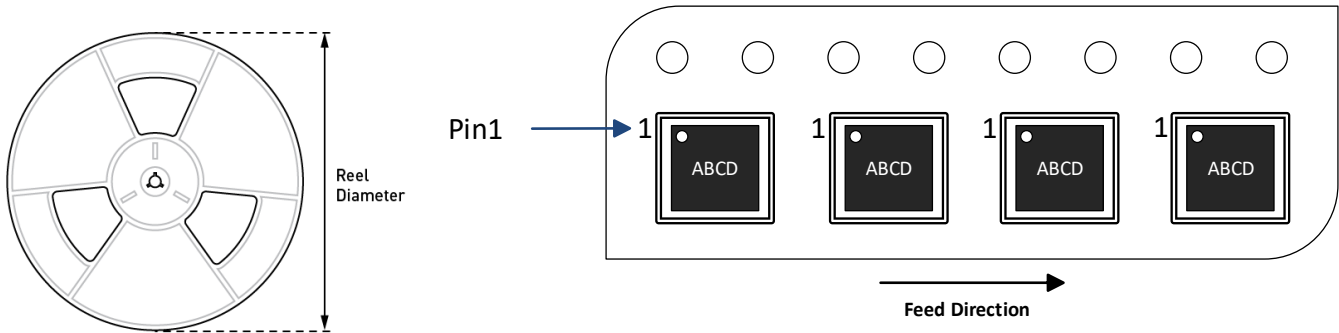
CARRIER INFORMATION

Part Number	Package Description	Quantity/ Reel	Quantity/ Tube	Quantity/ Tray	Reel Diameter	Carrier Tape Width	Carrier Tape Pitch
MP3371GR-Z	QFN-24 (4mmx4mm)	5000	RESERVED	RESERVED	13in	12mm	8mm

Notice: The information in this document is subject to change without notice. Users should warrant and guarantee that third-party Intellectual Property rights are not infringed upon when integrating MPS products into any application. MPS will not assume any legal responsibility for any said applications.