



MPQ3413

1.5A, 2.2MHz, 52 μ A I_Q, 5V V_{OUT},
Synchronous Step-Up Converter
with Output Disconnect, AEC-Q100 Qualified

DESCRIPTION

The MPQ3413 is a high-efficiency, synchronous, current mode, step-up converter with output disconnect.

The MPQ3413 can start up from an input voltage (V_{IN}) as low as 2.8V, and provides inrush current limiting and output short-circuit protection (SCP). The integrated P-channel synchronous rectifier (SR) improves efficiency and eliminates the requirement of an external Schottky diode. The MPQ3413's P-channel MOSFET disconnects the output from the input when the MPQ3413 shuts down. The output disconnect feature allows the output to be discharged completely, allowing the MPQ3413 to draw a supply current below 1 μ A in shutdown mode.

The 2.2MHz switching frequency (f_{sw}) allows for smaller external components, while the internal compensation and soft start (SS) minimize the external component count. These features result in a compact solution across a wide current load range.

The MPQ3413 features an integrated power MOSFET that supports an 5V output voltage (V_{OUT}) and a peak switching current above 1.5A.

The MPQ3413 is available in a small TSOT23-8 package.

FEATURES

- Supports 5V/0.3A Average Output Current (I_{OUT})
- 2.8V to 4V Input Voltage (V_{IN}) Range
- 5V Fixed Output Voltage (V_{OUT})
- Internal Synchronous Rectifier (SR)
- 2.2MHz Fixed Switching Frequency (f_{sw})
- 52 μ A Quiescent Current (I_Q)
- <1 μ A Shutdown Current
- True Output Disconnect from Input
- Up to 85% Efficiency
- Internal Compensation, Inrush Current Limiting, and Internal Soft Start (SS)
- Small External Components
- Over-Voltage Protection (OVP), Short-Circuit Protection (SCP), and Over-Temperature Protection (OTP)
- Available in a TSOT23-8 Package
- Available in AEC-Q100 Grade 1

APPLICATIONS

- Single-Cell, Li Battery Backup
- Automotive Secondary Regulation

All MPS parts are lead-free, halogen-free, and adhere to the RoHS directive. For MPS green status, please visit the MPS website under Quality Assurance. "MPS", the MPS logo, and "Simple, Easy Solutions" are trademarks of Monolithic Power Systems, Inc. or its subsidiaries.

TYPICAL APPLICATION

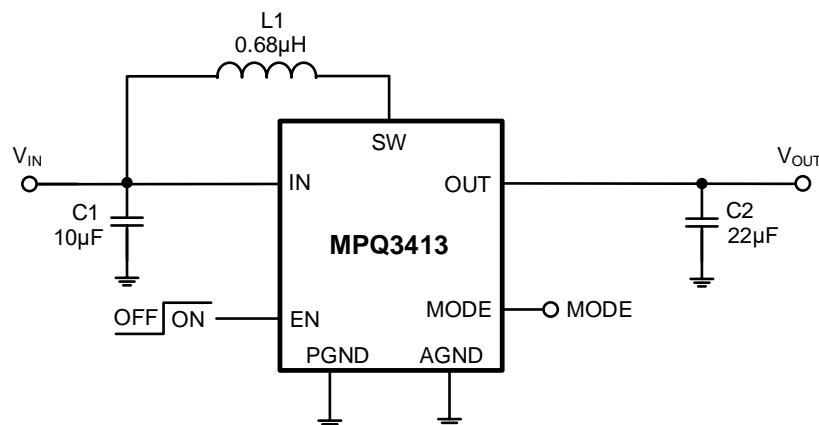

ORDERING INFORMATION

Part Number*	Package	Top Marking	MSL Rating
MPQ3413GJ-5-AEC1	TSOT23-8	See Below	1

* For Tape & Reel, add suffix -Z (e.g. MPQ3413GJ-5-AEC1-Z).

TOP MARKING

| BRFY

BRF: Product code

Y: Year code

PACKAGE REFERENCE

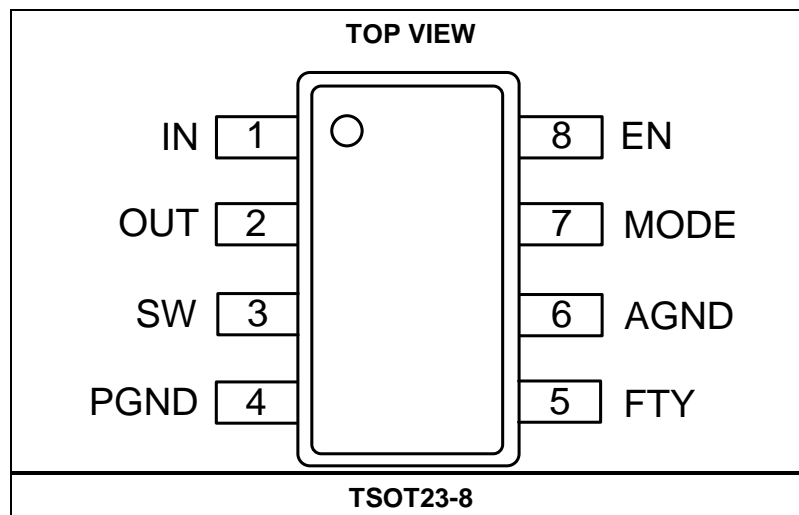

PIN FUNCTIONS

Pin #	Name	Description
1	IN	Power supply input. IN supplies the start-up bias and must be bypassed locally. When the output voltage (V_{OUT}) exceeds the input voltage (V_{IN}), the OUT pin supplies the bias power to the MPQ3413.
2	OUT	Output. The OUT pin is the internal synchronous rectifier (SR) MOSFET's drain. OUT supplies the bias power when V_{OUT} exceeds V_{IN} . Keep the PCB trace from OUT to the output filter capacitor(s) as short and wide as possible. When EN is pulled low, the MPQ3413's output disconnect feature allows OUT to be completely disconnected from IN. OUT is also the sensing point for regulation.
3	SW	Power MOSFET output. SW is the connection node between the internal low-side MOSFET (LS-FET) and synchronous MOSFET. Connect the power inductor between SW and the input power. To reduce EMI and voltage spikes, keep the PCB trace as short and wide as possible.
4	PGND	Power ground.
5	FTY	Factory use only. Float FTY or connect it to ground in application.
6	AGND	Analog ground.
7	MODE	Mode selection. Pull MODE logic high to enable advanced asynchronous modulation (AAM) mode; pull this pin logic low to enter forced continuous conduction mode (FCCM). MODE should not be changed while the MPQ3413 is in operation.
8	EN	Chip enable control input. Pull EN above 1.2V to turn on the regulator; pull this pin below 0.4V to turn off the regulator.

ABSOLUTE MAXIMUM RATINGS ⁽¹⁾

SW, OUT	-0.3V to +6.5V
SW (<5ns)	-0.3V to +9V
All other pins	-0.3V to +6.5V
Continuous power dissipation ($T_A = 25^\circ\text{C}$) ⁽²⁾	1.25W
Junction temperature	150°C
Lead temperature	260°C
Storage temperature	-65°C to +150°C

ESD Ratings

Human body model (HBM)	±2kV
Charged device model (CDM)	±750V

Recommended Operating Conditions ⁽³⁾

Supply voltage (V_{IN})	2.8V to 4V ⁽⁴⁾
Enable voltage (V_{EN})	0V to 4V
Operating junction temp (T_J)	-40°C to +125°C

Thermal Resistance ⁽⁵⁾ θ_{JA} θ_{JC}

TSOT23-8	100 55 ... °C/W
----------------	----------------------

Notes:

- Exceeding these ratings may damage the device.
- The maximum allowable power dissipation is a function of the maximum junction temperature, T_J (MAX), the junction-to-ambient thermal resistance, θ_{JA} , and the ambient temperature, T_A . The maximum allowable continuous power dissipation at any ambient temperature is calculated by P_D (MAX) = $(T_J$ (MAX) - T_A) / θ_{JA} . Exceeding the maximum allowable power dissipation can generate an excessive die temperature, which may cause the regulator to go into thermal shutdown. Internal thermal shutdown circuitry protects the device from permanent damage.
- The device is not guaranteed to function outside of its operating conditions.
- If V_{IN} is close to V_{OUT} , the boost converter may trigger minimum on time. When V_{IN} exceeds V_{OUT} , the boost converter switches between boost mode and linear charge mode. Both conditions result in a $V_{OUT-RIPPLE}$ that is too high. Therefore, this is not recommended.
- Measured on JESD51-7, 4-layer PCB.

ELECTRICAL CHARACTERISTICS

$V_{IN} = V_{EN} = 3.3V$, $V_{OUT} = 5V$, $T_J = -40^{\circ}C$ to $+125^{\circ}C$, typical values are tested at $T_J = 25^{\circ}C$, unless otherwise noted.

Parameters	Symbol	Condition	Min	Typ	Max	Units
Voltage Range						
Quiescent current	I_Q	$V_{MODE} = V_{EN} = V_{IN} = 3.3V$, $V_{OUT} = 6V$, no load, measured on OUT, $T_J = 25^{\circ}C$		52	80	μA
		$V_{MODE} = V_{EN} = V_{IN} = 3.3V$, $V_{OUT} = 6V$, no load, measured on IN, $T_J = 25^{\circ}C$		8	14	μA
Shutdown current	I_{SD}	$V_{EN} = V_{OUT} = 0V$, measured on IN, $T_J = 25^{\circ}C$		0.1	1	μA
IN under-voltage lockout (UVLO) threshold	V_{IN_UVLO}	V_{IN} rising, $T_J = 25^{\circ}C$		1.65	1.7	V
IN UVLO hysteresis				100		mV
Step-Up Converter						
Operation frequency	f_{SW}		1.9	2.2	2.5	MHz
V_{OUT} voltage reference	V_{REG}	$T_J = 25^{\circ}C$	4.9	5	5.1	V
		$T_J = -40^{\circ}C$ to $+125^{\circ}C$	4.875	5	5.125	V
N-channel MOSFET on resistance	$R_{DS(ON)_N}$			70		m Ω
N-channel MOSFET leakage current	I_{N_LK}	$V_{SW} = 6.5V$, $T_J = 25^{\circ}C$		0.1	1	μA
P-channel MOSFET on resistance	$R_{DS(ON)_P}$			80		m Ω
P-channel MOSFET leakage current	I_{P_LK}	$V_{SW} = 6.5V$, $V_{OUT} = 0V$, $T_J = 25^{\circ}C$		0.1	1	μA
Maximum duty cycle	D_{MAX}	$V_{IN} = 3.3V$		85		%
Start-up current limit	I_{ST_LIMIT}	$V_{IN} = 4V$, $V_{OUT} = 0V$	0.1	0.3	0.4	A
		$V_{IN} = 4V$, V_{OUT} setting = 3.6V, pull V_{OUT} to 3.3V	0.4	0.8	1	A
N-channel MOSFET current limit	I_{SW_LIMIT}	Duty = 40%	2.5	3.6	4.5	A
Logic Interface						
EN input high voltage	V_{EN_H}		1.2			V
EN input low voltage	V_{EN_L}				0.4	V
EN input current	I_{EN}	Connect to V_{IN}		10		nA
Protections						
Thermal shutdown ⁽⁶⁾			150	160	175	$^{\circ}C$
Over-temperature hysteresis ⁽⁶⁾				25		$^{\circ}C$

Note:

6) Guaranteed by characterization. Not tested in production.

TYPICAL PERFORMANCE CHARACTERISTICS

$V_{IN} = 3.3V$, $V_{OUT} = 5V$, $L = 0.68\mu H$, $T_A = 25^\circ C$, unless otherwise noted.

AAM Mode Load Efficiency

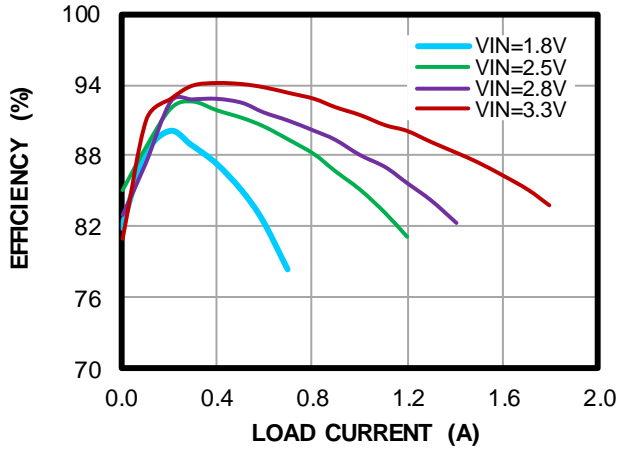

AAM Mode Line Efficiency

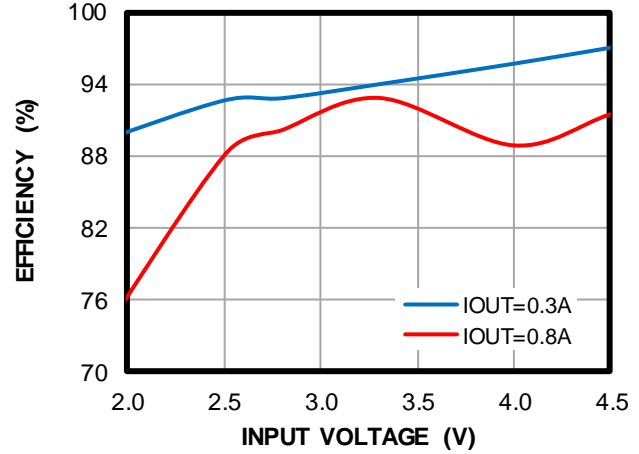

AAM Mode Load Regulation

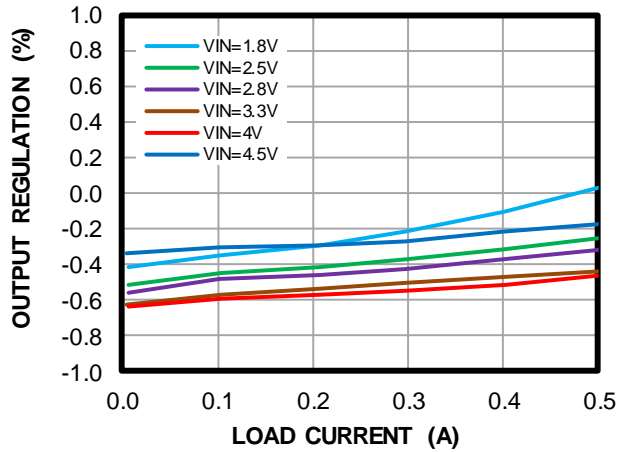

AAM Mode Line Regulation

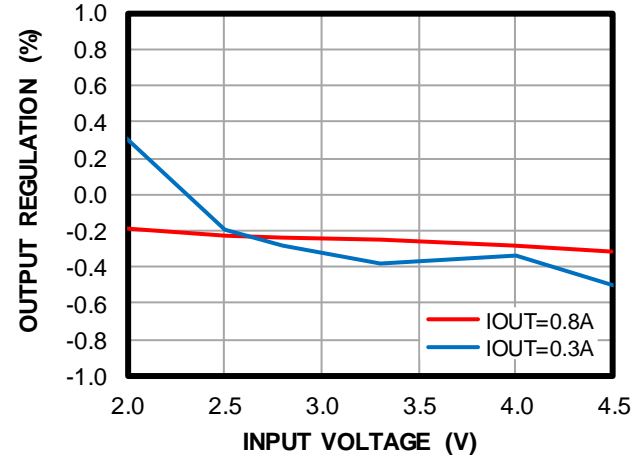

FCCM Load Efficiency

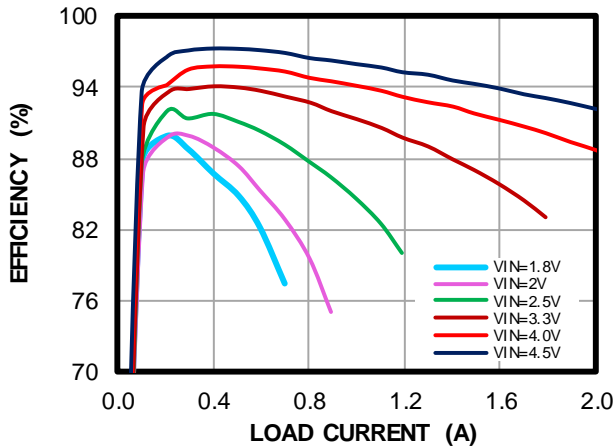

FCCM Line Efficiency

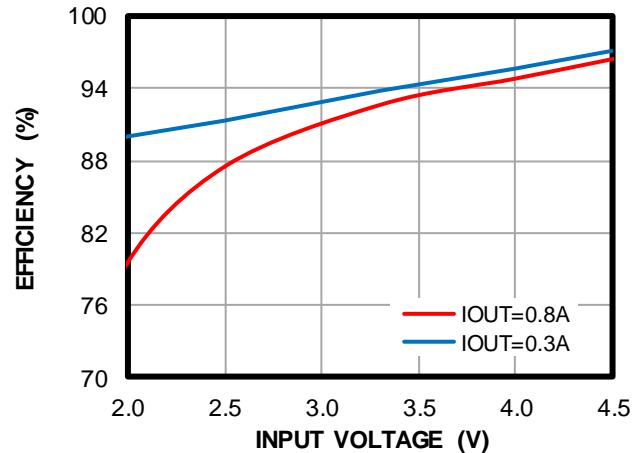

TYPICAL PERFORMANCE CHARACTERISTICS *(continued)*

$V_{IN} = 3.3V$, $V_{OUT} = 5V$, $L = 0.68\mu H$, $T_A = 25^\circ C$, unless otherwise noted.

FCCM Load Regulation

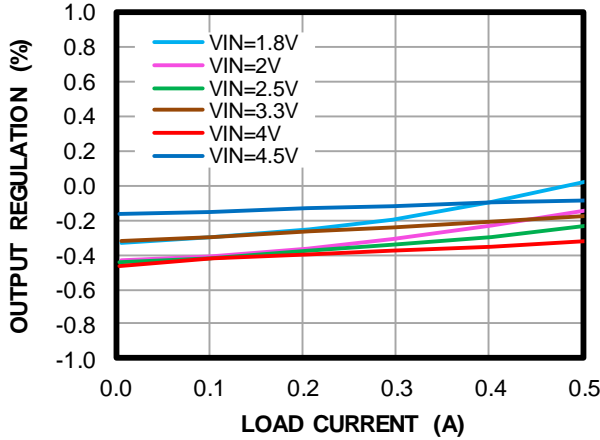

FCCM Line Regulation

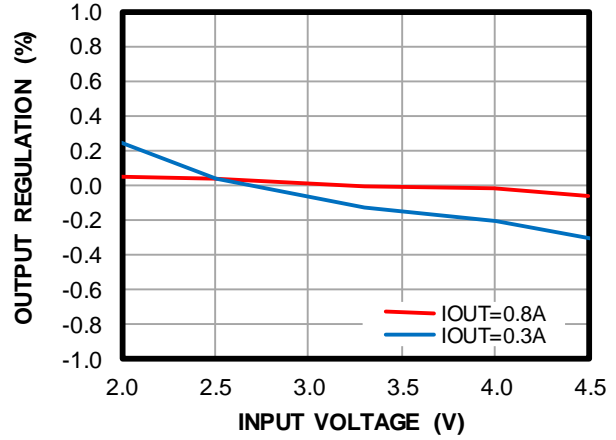

Quiescent Current vs. Ambient Temperature

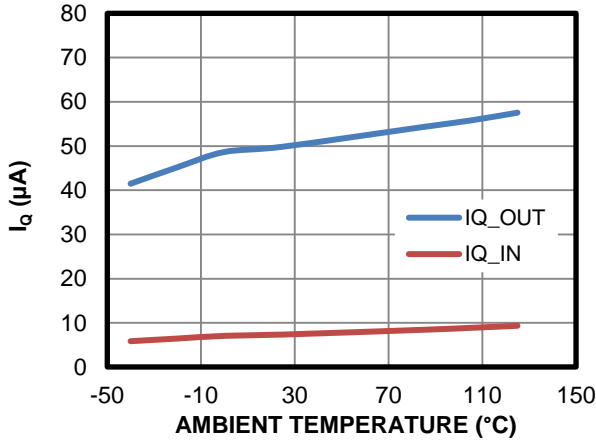

UVLO On/Off vs. Ambient Temperature

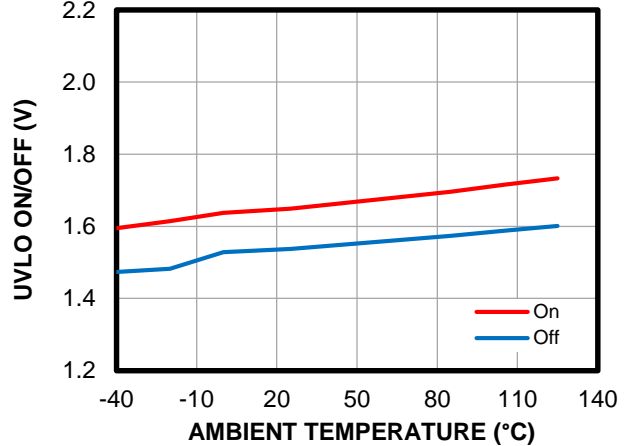

EN On/Off vs. Ambient Temperature

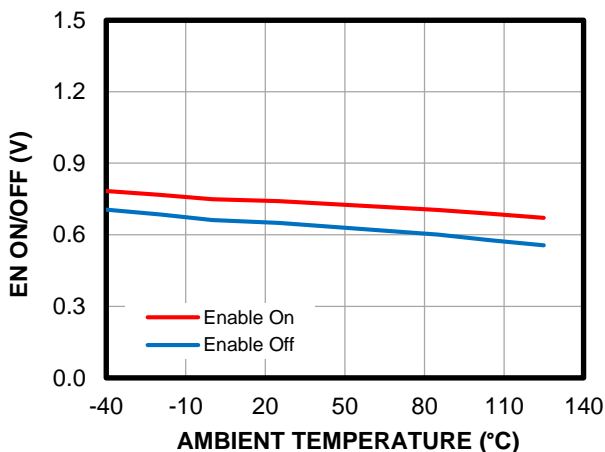

Switching Frequency vs. Ambient Temperature

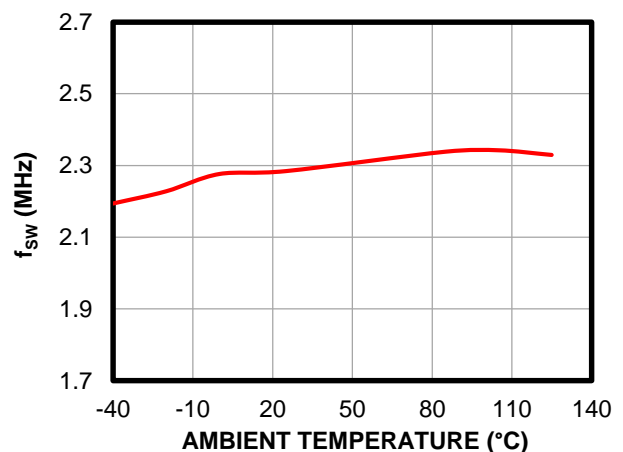

TYPICAL PERFORMANCE CHARACTERISTICS *(continued)*

$V_{IN} = 3.3V$, $V_{OUT} = 5V$, $L = 0.68\mu H$, $T_A = 25^\circ C$, unless otherwise noted.

Output Voltage vs. Ambient Temperature

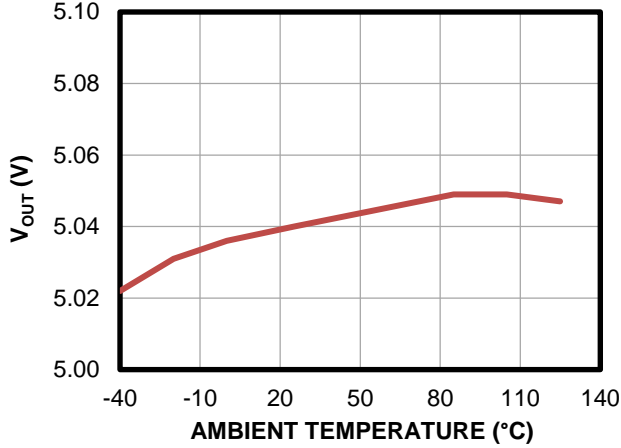

Shutdown Current vs. Ambient Temperature

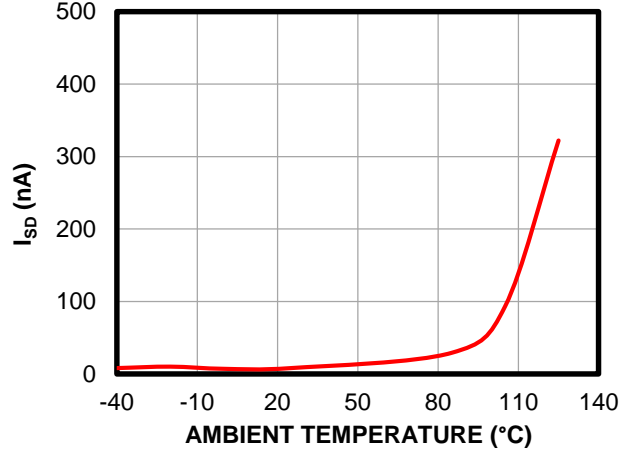

TYPICAL PERFORMANCE CHARACTERISTICS (continued)
 $V_{IN} = 3.3V$, $V_{OUT} = 5V$, $L = 0.68\mu H$, $T_A = 25^\circ C$, unless otherwise noted.

Steady State

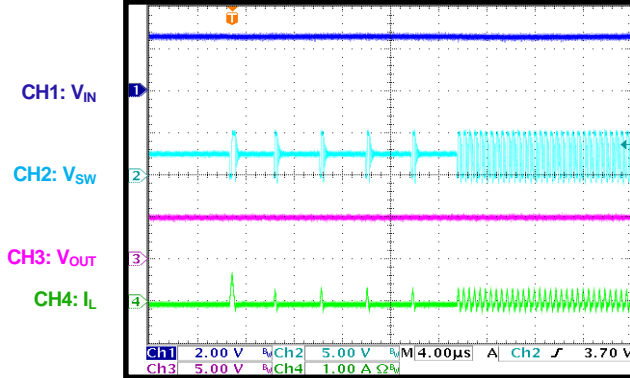
 AAM mode, $V_{IN} = 2.5V$, $I_{OUT} = 0A$

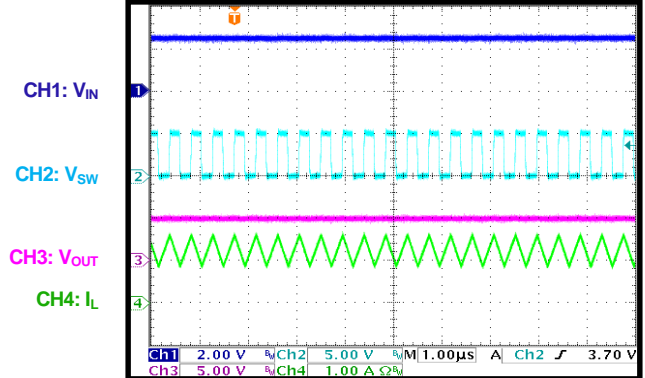
Steady State

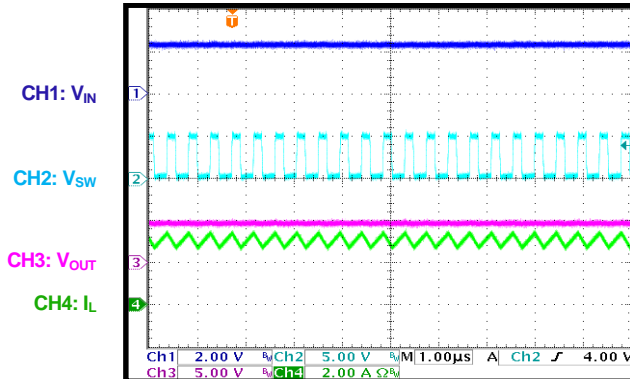
 AAM mode, $V_{IN} = 2.5V$, $I_{OUT} = 0.6A$

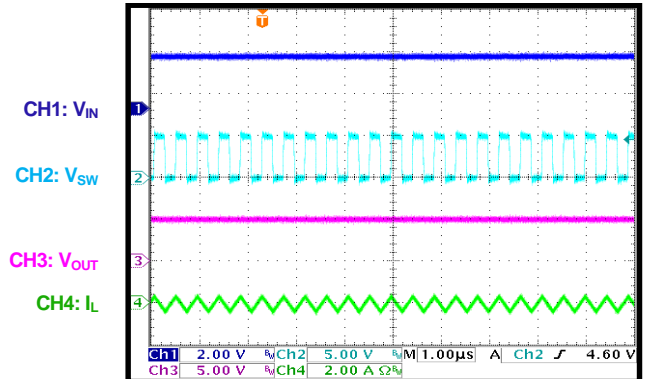
Steady State

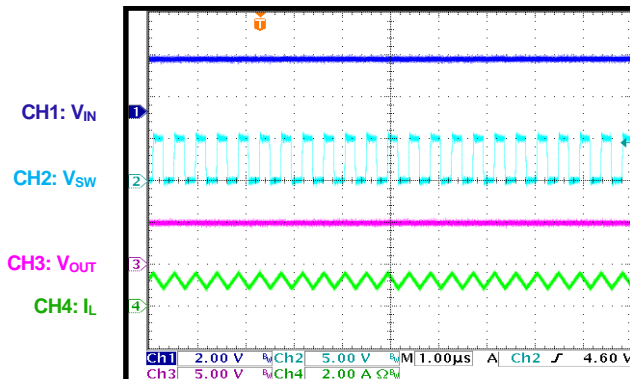
 AAM mode, $V_{IN} = 2.5V$, $I_{OUT} = 1.2A$

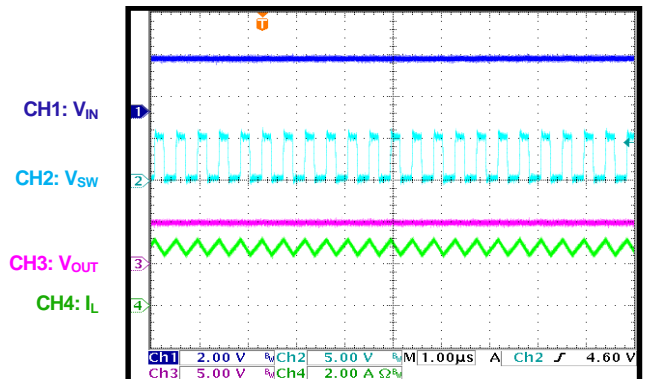
Steady State

 FCCM, $V_{IN} = 2.5V$, $I_{OUT} = 0A$

Steady State

 FCCM, $V_{IN} = 2.5V$, $I_{OUT} = 0.6A$

Steady State

 FCCM, $V_{IN} = 2.5V$, $I_{OUT} = 1.2A$

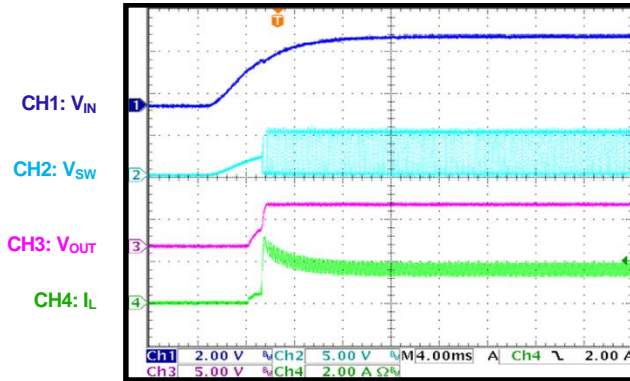
TYPICAL PERFORMANCE CHARACTERISTICS (continued)
 $V_{IN} = 3.3V$, $V_{OUT} = 5V$, $L = 0.68\mu H$, $T_A = 25^\circ C$, unless otherwise noted.

Start-Up through VIN

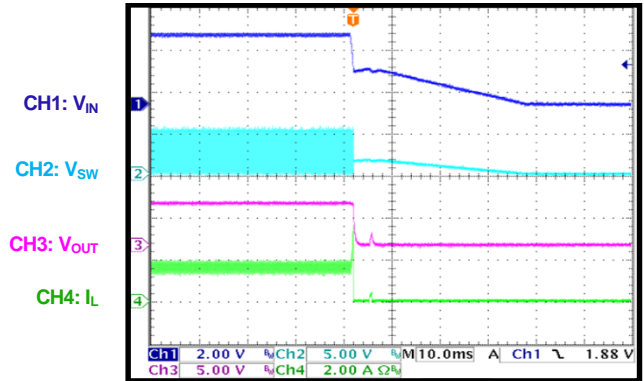
 FCCM, $V_{IN} = 3.3V$, $I_{OUT} = 1A$

Shutdown through VIN

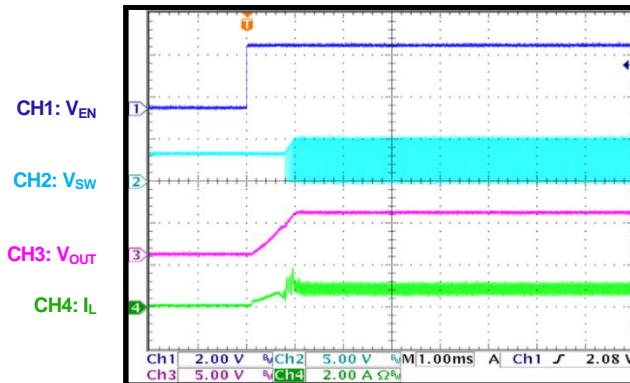
 FCCM, $V_{IN} = 3.3V$, $I_{OUT} = 1A$

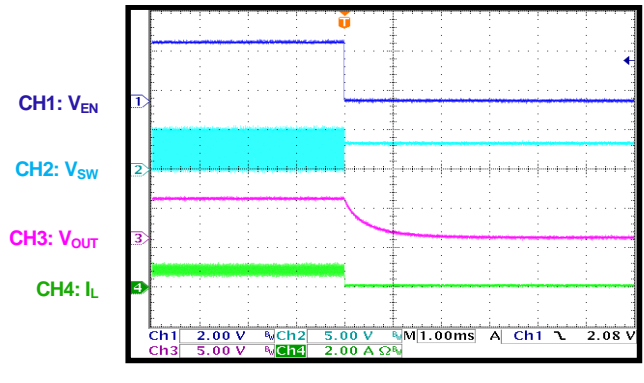
Start-Up through EN

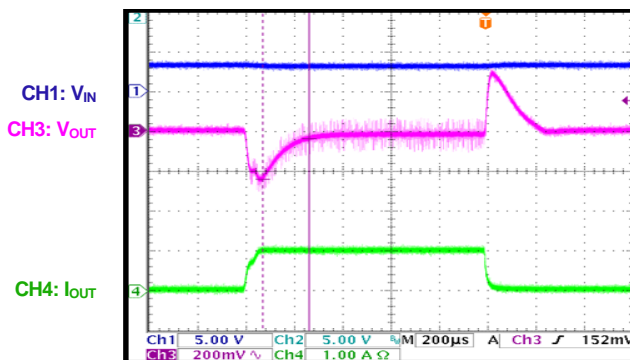
 FCCM, $V_{IN} = 3.3V$, $I_{OUT} = 0.5A$

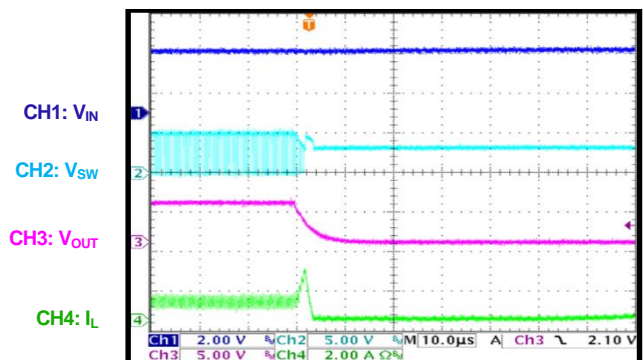
Shutdown through EN

 FCCM, $V_{IN} = 3.3V$, $I_{OUT} = 0.5A$

Load Transient

 FCCM, $V_{IN} = 3.3V$, $I_{OUT} = 0A$ to $1A$,
slew rate = $2.5A/\mu s$

Short-Circuit Protection (SCP)

 FCCM, $V_{IN} = 3.3V$, $I_{OUT} = 0.5A$

TYPICAL PERFORMANCE CHARACTERISTICS *(continued)*

$V_{IN} = 3.3V$, $V_{OUT} = 5V$, $L = 0.68\mu H$, $T_A = 25^\circ C$, unless otherwise noted.

SCP Recovery

FCCM, $V_{IN} = 3.3V$, $I_{OUT} = 0.5A$

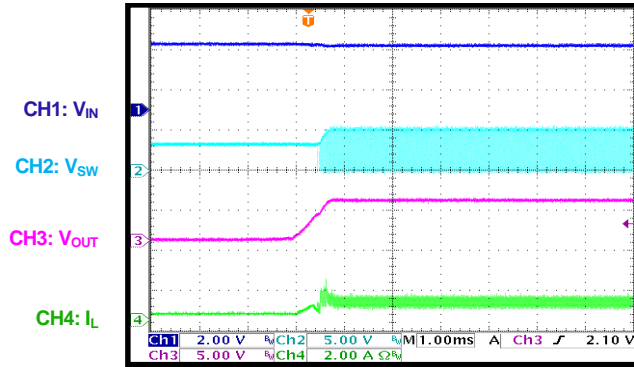

Over-Voltage Protection (OVP)

$V_{IN} = 2.5V$, $I_{OUT} = 0.5A$

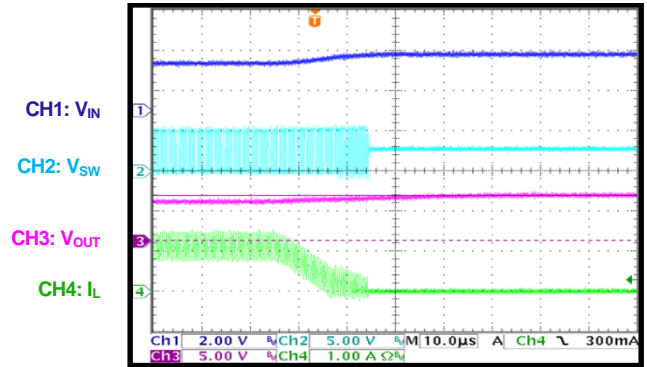

OVP Recovery

$V_{IN} = 2.5V$, $I_{OUT} = 0.5A$

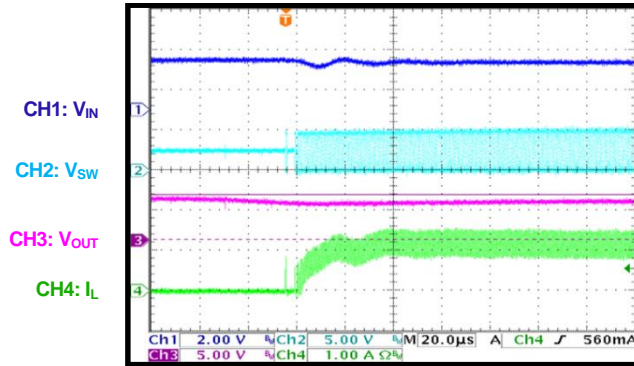

FUNCTIONAL BLOCK DIAGRAM

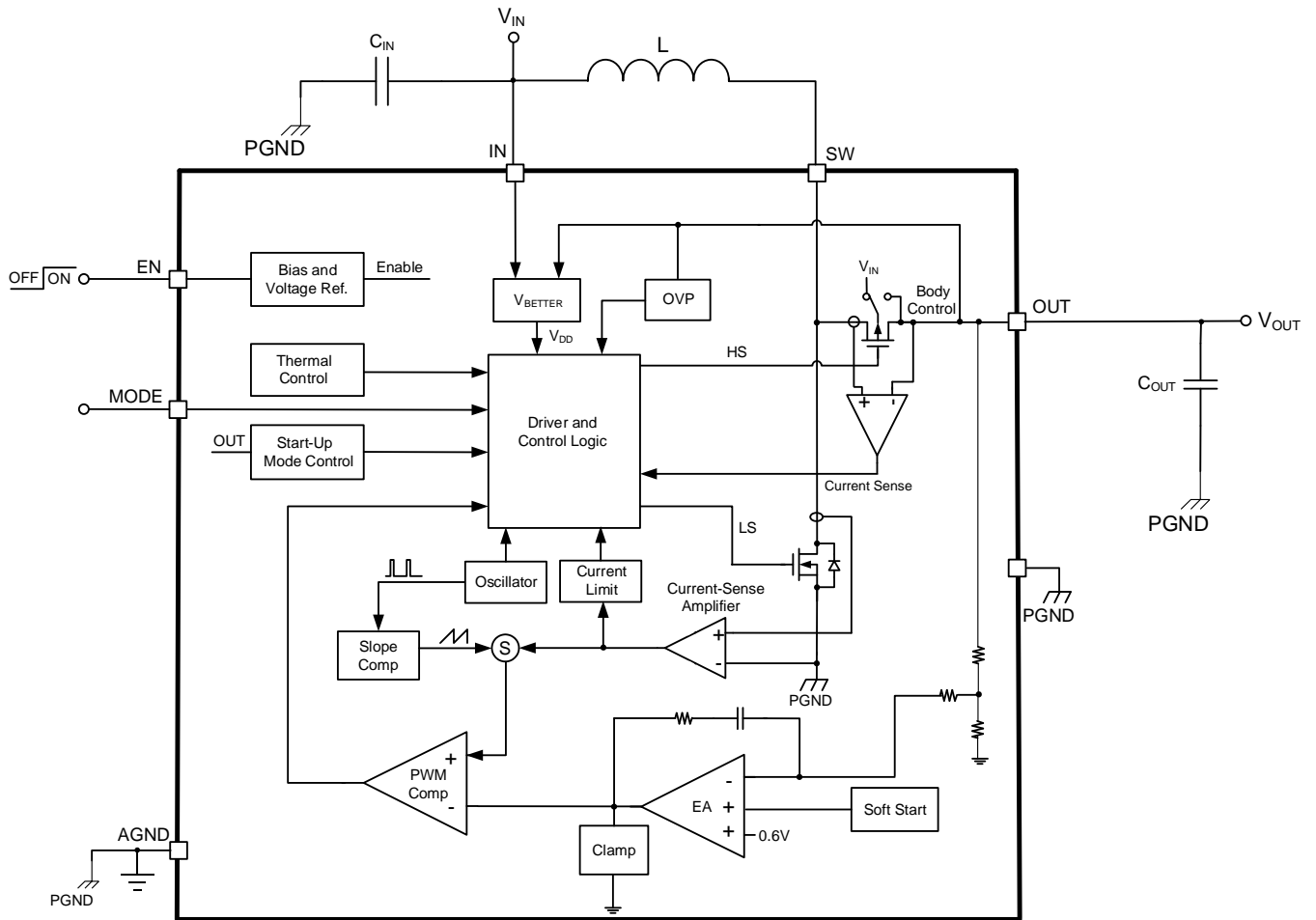

Figure 1: Functional Block Diagram

OPERATION

The MPQ3413 is a 2.2MHz, synchronous step-up converter in a compact TSOT23 package with true output disconnect. The MPQ3413 features fixed-frequency, current-mode, pulse-width modulation (PWM) control to achieve good line and load regulation.

Internal soft start (SS) and loop compensation simplify the design process and minimize the number of required external components. The internal low on resistance ($R_{DS(ON)}$) MOSFETs, combined with frequency stretching, allow the MPQ3413 to maintain high efficiency across a wide current load range.

Start-Up

When enabled, the MPQ3413 starts up in linear-charge mode. During linear charge, the rectified P-channel MOSFET turns on until the output voltage (V_{OUT}) is charged close to the input voltage (V_{IN}).

To avoid inrush current, the P-channel MOSFET current is limited to about 0.3A (when V_{OUT} is 0V). The P-channel MOSFET linear charge current limit increases to about 0.8A while V_{OUT} rises to 3.3V (if V_{IN} exceeds 3.3V). This circuit helps limit the output current (I_{OUT}) under short-circuit conditions.

When V_{OUT} reaches V_{IN} , the linear charging period completes and the device starts switching. V_{OUT} starts to rise under internal SS control. Under boost switching conditions, the current limit is typically 3.6A.

When V_{OUT} exceeds V_{IN} , the MPQ3413 powers its internal circuits from V_{OUT} instead of V_{IN} . This allows for strong driving capabilities and high efficiency, even if V_{IN} drops as low as 1.8V.

Soft Start (SS)

The MPQ3413 provides SS by charging an internal capacitor using a current source. During the linear charging period, the SS signal continues rising, following the feedback (FB) signal. When the linear charge completes, the voltage on the SS capacitor (C_{SS}) is charged and ramps up the reference voltage (V_{REF}) based on the internal fixed slew rate. C_{SS} is discharged completely during shutdown, thermal shutdown, and output short circuit.

Enable (EN)

The MPQ3413 begins operating if EN is pulled above 1.2V. If EN is pulled below 0.4V, then the device enters shutdown mode. In shutdown mode, the regulator stops switching, all internal control circuits switch off, and the output disconnects from the input completely.

Power-Save Mode (PSM)

The MPQ3413 enters power-save mode (PSM) automatically if the MODE pin is pulled logic high when the load decreases. The device switches back to pulse-width modulation (PWM) mode when the load increases.

In PSM, the converter stretches the frequency down to save switching and driver losses. Additionally, the switching frequency (f_{SW}) is stretched down when V_{IN} is close to V_{OUT} , which then triggers the minimum on time if maintained at a 2.2MHz frequency. This helps decrease the output ripple by avoiding group-pulse mode. Under very light-load conditions, the MPQ3413 continues to operate in group-pulse mode to regulate V_{OUT} and save more power.

If MODE is pulled logic low, the MPQ3413 operates in forced continuous conduction mode (FCCM), resulting in a consistent frequency across the entire load range.

Changing the mode setting from PSM to FCCM during operation may cause a disturbance in V_{OUT} . Therefore, it is recommended to not change MODE during operation.

Error Amplifier (EA)

The error amplifier (EA) is an internally compensated amplifier. The EA compares the internal 0.6V V_{REF} against the FB voltage (V_{FB}) to generate an EA signal, which in turn controls the MPQ3413's V_{OUT} , fixed at 5V.

Current Sensing

Under linear charging conditions, the high-side P-channel MOSFET current is sensed and compared with the current limit threshold. The compared output regulates the linear charge current.

Under boost switching conditions, lossless current sensing converts the N-channel MOSFET current signal into a voltage that is

combined with the internal slope compensation. The total signal is compared with the EA output to provide peak current control for PWM. The peak MOSFET current is limited to approximately 3.6A. The MOSFET current signal is blanked internally for 60ns to enhance noise immunity.

Output Disconnect

The MPQ3413 is designed to allow a true output disconnect by eliminating the internal P-channel MOSFET rectifier's body diode conduction. This allows V_{OUT} to reach 0V during shutdown, drawing zero current from the input source.

This also allows for inrush current limiting at start-up, which minimizes the input supply's surge current. To achieve the advantages of output disconnect, do not connect an external Schottky diode between SW and V_{OUT} .

Overload and Short-Circuit Protection (SCP)

V_{OUT} drops when an overload or a short circuit occurs. If V_{OUT} drops below V_{IN} (0.3V), the MPQ3413 stops for about 50 μ s and then operates in linear-charge mode at start-up. If the overload or short circuit is removed, the MPQ3413 restarts automatically with a SS.

Over-Voltage Protection (OVP)

If V_{OUT} exceeds the typical 6V threshold, boost switching stops. After V_{OUT} drops to about 5.7V, switching recovers automatically. This protects the internal power MOSFET from over-voltage stress.

Thermal Shutdown

The MPQ3413 supports internal temperature monitoring. If the die temperature exceeds 155°C, the converter turns off. Once the temperature drops below 130°C, the converter restarts and resumes normal operation.

APPLICATION INFORMATION

Selecting the Input Capacitor

A low-ESR input capacitor (C_{IN}) reduces input switching noise and the peak current drawn from the battery. Ceramic capacitors are recommended for input decoupling, and should be placed as close to the device as possible. A ceramic capacitor above 10 μ F is recommended to limit the V_{IN} ripple.

Selecting the Output Capacitor

To ensure stability across the full operating range, the output capacitor (C_{OUT}) requires a minimum 22 μ F capacitance at the configured V_{OUT} . A higher capacitance may be required to reduce the output and transient ripple. Low-ESR capacitors, such as X5R or X7R capacitors, are recommended. To support the ripple in PWM when the ESR is zero, the minimum C_{OUT} can be calculated using Equation (1):

$$C_{OUT} \geq \frac{I_{OUT} \times (V_{OUT(MAX)} - V_{IN(MIN)})}{f_{SW} \times V_{OUT(MAX)} \times \Delta V_{OUT}} \quad (1)$$

Where $V_{OUT(MAX)}$ is the maximum output voltage, $V_{IN(MIN)}$ is the minimum input voltage, I_{OUT} is the output current, f_{SW} is the switching frequency, and ΔV_{OUT} is the acceptable output voltage ripple.

A 1 μ F ceramic capacitor is recommended between V_{OUT} and PGND with a short loop. This reduces spikes on SW and improves EMI performance.

Selecting the Inductor

The MPQ3413 utilizes small surface-mount chip inductors due to the 2.2MHz f_{SW} . Inductances between 0.47 μ H and 1.2 μ H are suitable for most applications. Larger inductances allow for improved I_{OUT} capabilities by reducing the inductor ripple current. However, larger inductances increase the component size. The minimum inductance (L) can be calculated using Equation (2):

$$L \geq \frac{V_{IN(MIN)} \times (V_{OUT(MAX)} - V_{IN(MIN)})}{V_{OUT(MAX)} \times \Delta I_L \times f_{SW}} \quad (2)$$

Where ΔI_L is the acceptable inductor current ripple.

Typically, ΔI_L is set to be 30% to 50% of the maximum inductor current. A low DCR must be maintained to reduce resistive power loss. The saturated current (I_{SAT}) should be large enough to support the peak current.

Design Example

Table 1 shows a design example following the application guidelines for the recommended specifications.

Table 1: Design Example

V_{IN}	V_{OUT}	I_{OUT}
2.8V to 4V	5V	0A to 0.3A

Figure 3 on page 16 shows the detailed application schematic and basis for the typical performance waveforms at $V_{OUT} = 5V$. For additional device applications, refer to the related evaluation board datasheet.

PCB Layout Guidelines

Efficient PCB layout is critical for high-frequency switching power supplies. Poor layout can result in reduced performance, excessive EMI, resistive loss, system instability, and even over-voltage stress. For the best results, refer to Figure 2 and follow the guidelines below:

1. Place C_{OUT} as close as possible to OUT and PGND.
2. Place a small decoupling capacitor in parallel with the bulk C_{OUT} . Place the small decoupling capacitor as close as possible to OUT and PGND. This is very important to reduce the spikes on SW and improve EMI performance.
3. Place C_{IN} and the inductor as close as possible to IN and SW. The trace between the inductor and SW should be as wide and short as possible.

4. Place the feedback (FB) loop far away from all noise sources such as SW. The FB divider resistors should be as close as possible to FB and AGND.
5. Tie the ground returns for C_{IN} and C_{OUT} as close as possible to PGND using a large copper GND area. Vias around GND are recommended to lower the die temperature.

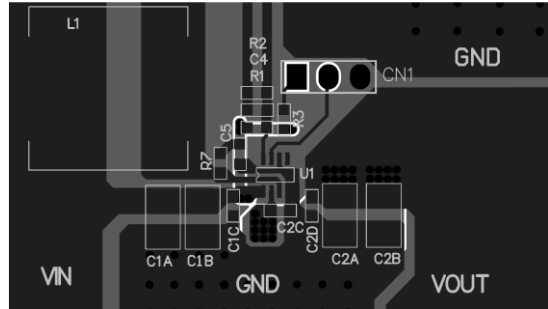

Figure 2: Recommended PCB Layout

TYPICAL APPLICATION CIRCUIT

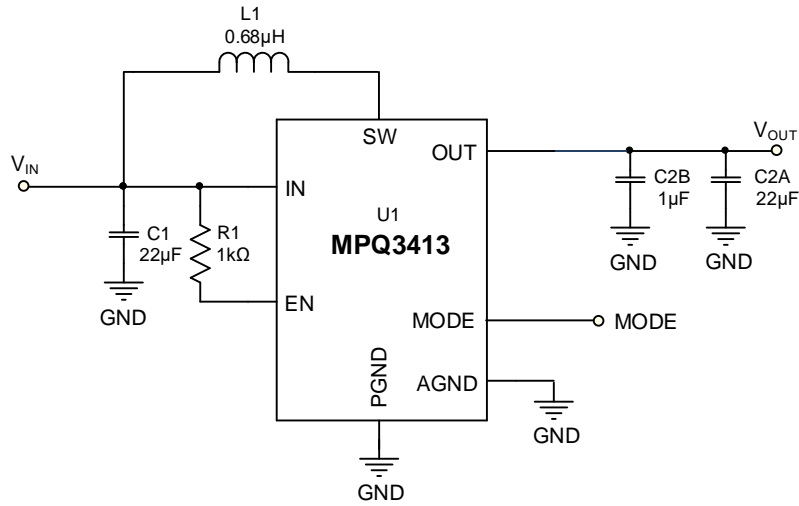
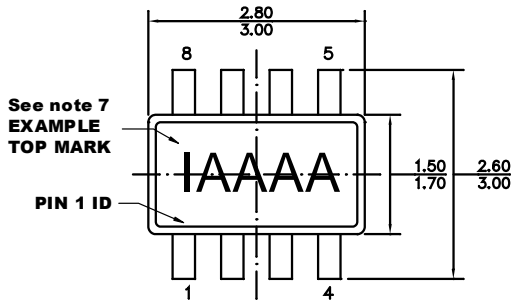

Figure 3: Typical Boost Application Circuit ($V_{IN} = 2.8V$ to $4V$, $V_{OUT} = 5V$, $I_{OUT} = 0A$ to $0.3A$)

PACKAGE INFORMATION

TSOT23-8



TOP VIEW

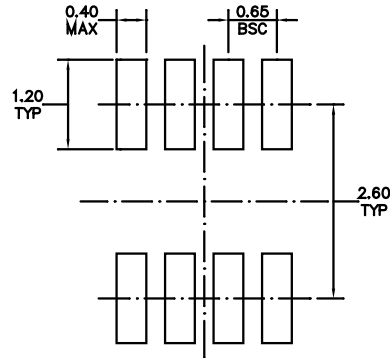

RECOMMENDED LAND PATTERN

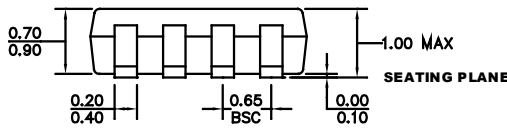

FRONT VIEW

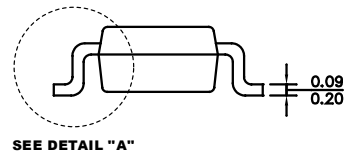

SIDE VIEW

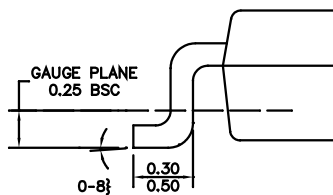

DETAIL "A"

NOTES:

- 1) ALL DIMENSIONS ARE IN MILLIMETERS.
- 2) PACKAGE LENGTH DOES NOT INCLUDE MOLD FLASH, PROTRUSION, OR GATE BURR.
- 3) PACKAGE WIDTH DOES NOT INCLUDE INTERLEAD FLASH OR PROTRUSION.
- 4) LEAD COPLANARITY (BOTTOM OF LEADS AFTER FORMING) SHALL BE 0.10 MILLIMETERS MAX.
- 5) JEDEC REFERENCE IS MO-193, VARIATION BA.
- 6) DRAWING IS NOT TO SCALE.
- 7) PIN 1 IS LOWER LEFT PIN WHEN READING TOP MARK FROM LEFT TO RIGHT (SEE EXAMPLE TOP MARK).

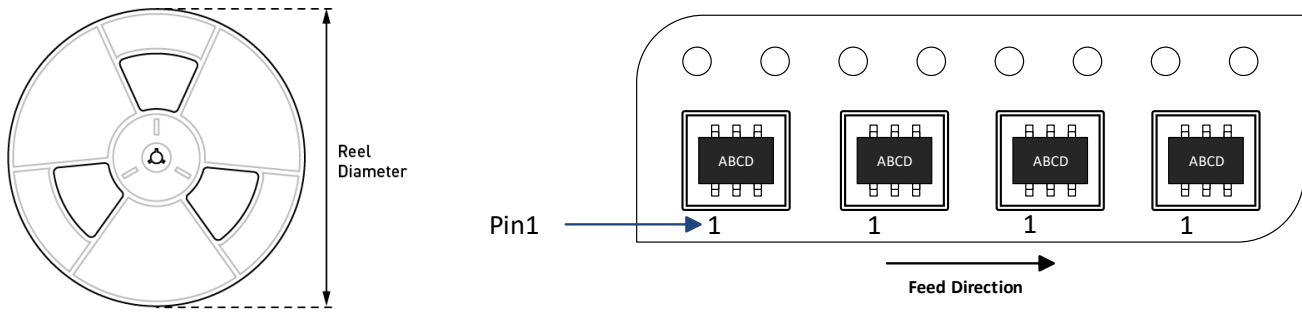
CARRIER INFORMATION

Part Number	Package Description	Quantity/ Reel	Quantity/ Tube	Quantity/ Tray	Reel Diameter	Carrier Tape Width	Carrier Tape Pitch
MPQ3413GJ-5-AEC1-Z	TSOT23-8	3000	N/A	N/A	7in	8mm	4mm

REVISION HISTORY

Revision #	Revision Date	Description	Pages Updated
1.0	2/10/2022	Initial Release	-

Notice: The information in this document is subject to change without notice. Users should warrant and guarantee that third-party Intellectual Property rights are not infringed upon when integrating MPS products into any application. MPS will not assume any legal responsibility for any said applications.