

### DESCRIPTION

The MPQ1542 is a current-mode, step-up converter with a 2A, 0.18Ω internal switch that provides a highly efficient regulator with fast response. The MPQ1542 can be operated at 700kHz or 1.3MHz, allowing for easy filtering and low noise. An external compensation pin provides flexibility in setting loop dynamics, which allows the use of small, low ESR, ceramic output capacitors. Soft start results in a small inrush current and can be programmed with an external capacitor. The MPQ1542 operates from an input voltage as low as 2.5V and can generate 12V at up to 500mA from a 5V supply.

Full protection features include under-voltage lockout (UVLO), current limiting, and thermal overload protection, which prevents damage in the event of an output overload. The MPQ1542 is available in a low profile, 8-pin, MSOP package.

### FEATURES

- 2A, 0.18Ω, 25V Power MOSFET
- Uses Tiny Capacitors and Inductors
- Pin Selectable 700kHz or 1.3MHz Fixed Switching Frequency
- Programmable Soft Start
- Operates with Input Voltage as Low as 2.5V and Output Voltage as High as 22V
- 12V at 500mA from 5V Input
- Under-Voltage Lockout (UVLO), Thermal Shutdown
- Internal Current Limit
- Available in an 8-Pin MSOP Package

### APPLICATIONS

- LCD Displays
- Portable Applications
- Handheld Computers and PDAs
- Digital Still and Video Cameras

All MPS parts are lead-free, halogen-free, and adhere to the RoHS directive. For MPS green status, please visit the MPS website under Quality Assurance. "MPS" and "The Future of Analog IC Technology" are registered trademarks of Monolithic Power Systems, Inc.

### TYPICAL APPLICATION

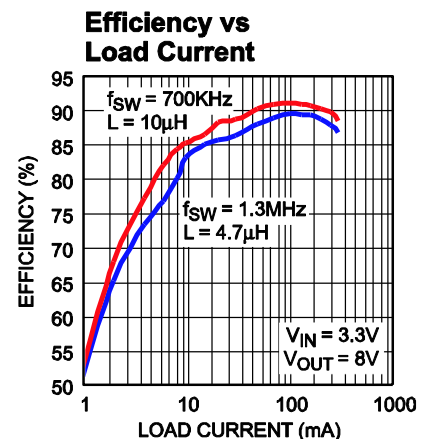
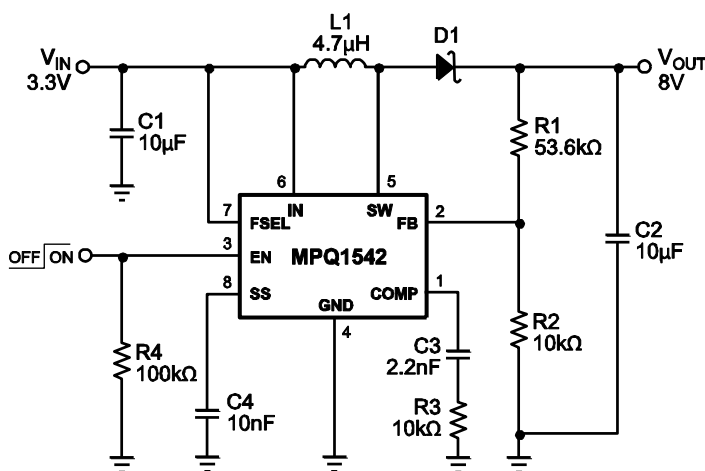

### ORDERING INFORMATION

Part Number*	Package	Top Marking
MPQ1542DK	MSOP-8	See Below

\* For Tape & Reel, add suffix –Z (e.g. MPQ1542DK–Z)  
 For Lead Free, add suffix –LF (e.g. MPQ1542DK–LF–Z)

### TOP MARKING

YWLLL  
 1542D

Y: Year code  
 W: Week code  
 LLL: Lot number  
 1542: First five digits of the part number  
 D: Product code of MPQ1542DK

### PACKAGE REFERENCE

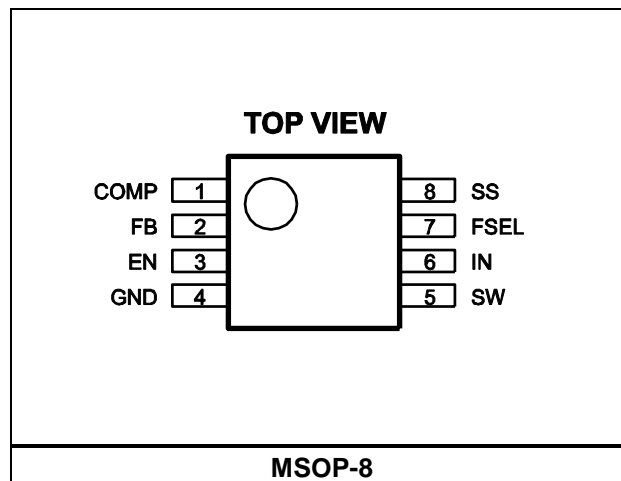

**ABSOLUTE MAXIMUM RATINGS (1)**

SW.....	-0.5V (-1V for < 50ns) to +25V
IN.....	-0.5V to +25V
All other pins.....	-0.3V to +6.5V
Continuous power dissipation (T <sub>A</sub> = +25°C) (2)	
.....	0.83W
Junction temperature .....	150°C
Lead temperature .....	260°C
Storage temperature.....	-65°C to +150°C

**Recommended Operating Conditions**

Supply voltage (V <sub>IN</sub> ) .....	2.5V to 22V
Output voltage (V <sub>OUT</sub> ).....	3V to 22V
Operating junction temp. (T <sub>J</sub> )..	-40°C to +125°C

<b>Thermal Resistance (3)</b>	<b>θ<sub>JA</sub></b>	<b>θ<sub>JC</sub></b>
MSOP-8 .....	150.....	65 ... °C/W

**NOTES:**

- 1) Exceeding these ratings may damage the device.
- 2) The maximum allowable power dissipation is a function of the maximum junction temperature. T<sub>J</sub>(MAX) the junction-to-ambient thermal resistance. θ<sub>JA</sub> and the ambient temperature, T<sub>A</sub> the maximum allowable power dissipation at any ambient temperature is calculated using: P<sub>D</sub>(MAX)=(T<sub>J</sub>(MAX)-T<sub>A</sub>)/ θ<sub>JA</sub>. Exceeding the maximum allowable power dissipation produces an excessive die temperature, causing the device to go into thermal shutdown. Internal thermal shutdown circuitry protects the device from permanent damage.
- 3) Measured on JESD51-7, 4-layer PCB.

## ELECTRICAL CHARACTERISTICS

$V_{IN} = V_{EN} = 5V$ , typical values are tested at  $T_J = +25^\circ C$ , unless otherwise noted.

Parameter	Symbol	Condition	Min	Typ	Max	Units	
Operating input voltage	$V_{IN}$		2.5		22	V	
Under-voltage lockout		$V_{IN}$ rising	$T_J = +25^\circ C$	2.15		2.45	V
			$T_J = -40^\circ C - 125^\circ C$	2.1		2.45	
Under-voltage lockout hysteresis				100		mV	
Supply current (shutdown)		$V_{EN} = 0V$		0.1	1	$\mu A$	
Supply current (quiescent)		$V_{FB} = 1.35V$		700	900	$\mu A$	
Switching frequency	$f_{sw}$	$V_{FSEL} = V_{IN}$	$T_J = +25^\circ C$	1.1	1.3	1.6	MHz
			$T_J = -40^\circ C - 125^\circ C$	1.0	1.3	1.6	
		$V_{FSEL} = GND$	$T_J = +25^\circ C$	580	700	840	kHz
			$T_J = -40^\circ C - 125^\circ C$	540	700	840	
FSEL high threshold		$V_{FSEL}$ rising			2V	V	
FSEL low threshold			0.5			V	
Maximum duty cycle		$V_{FB} = 0V, V_{FSEL} = V_{IN}$	85	90		%	
		$V_{FB} = 0V, V_{FSEL} = GND$	92	95			
EN high threshold		$V_{EN}$ rising			1.5	V	
EN low threshold		$T_J = +25^\circ C$	0.5			V	
		$T_J = -40^\circ C - 125^\circ C$	0.45				
EN input bias current		$V_{EN} = 0V, 5V$			1	$\mu A$	
Soft-start current				6		$\mu A$	
FB voltage			$T_J = +25^\circ C$	1.225	1.25	1.275	V
			$T_J = -40^\circ C - 125^\circ C$	1.22		1.28	
FB input bias current			-200	-100		nA	
Error amp voltage gain <sup>(4)</sup>	$A_{VEA}$			1000		V/V	
Error amp transconductance	$G_{EA}$			350		$\mu A/V$	
Error amp output current				35		$\mu A$	
SW on resistance <sup>(4)</sup>	$R_{ON}$			0.18		$\Omega$	
SW current limit <sup>(4)</sup>		Duty cycle = 0%		2.6		A	
SW current limit <sup>(4)</sup>		Duty cycle = 50%		2		A	
SW leakage		$V_{SW} = 20V$			1	$\mu A$	
Thermal shutdown <sup>(4)</sup>				160		$^\circ C$	

**NOTE:**

4) Guaranteed by design.

## TYPICAL PERFORMANCE CHARACTERISTICS

Circuit on page 1,  $V_{IN} = 3.3V$ ,  $V_{OUT} = 8V$ , unless otherwise noted.

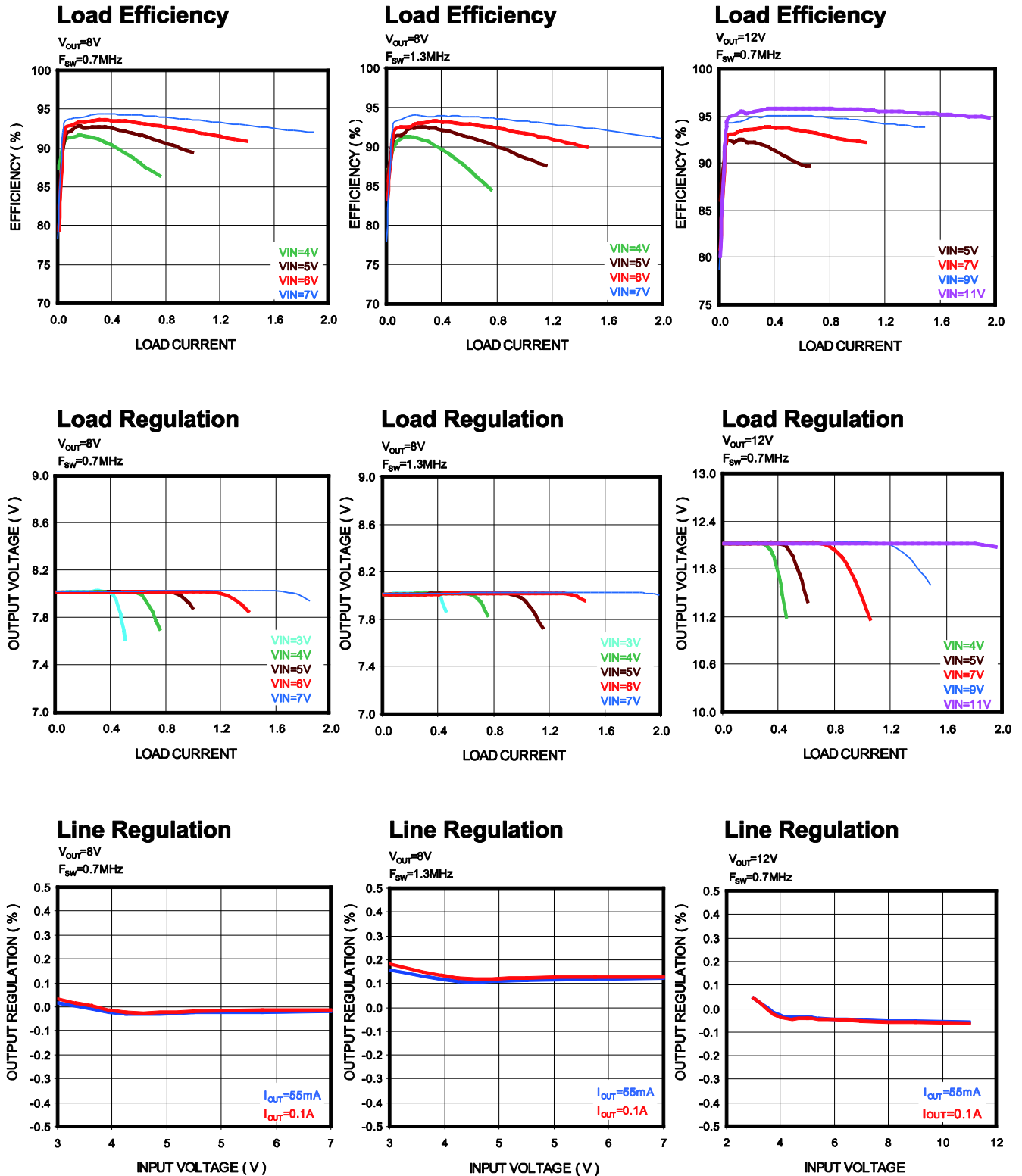

**TYPICAL PERFORMANCE CHARACTERISTICS (continued)**

 Circuit on page 1,  $V_{IN} = 3.3V$ ,  $V_{OUT} = 8V$ , unless otherwise noted.

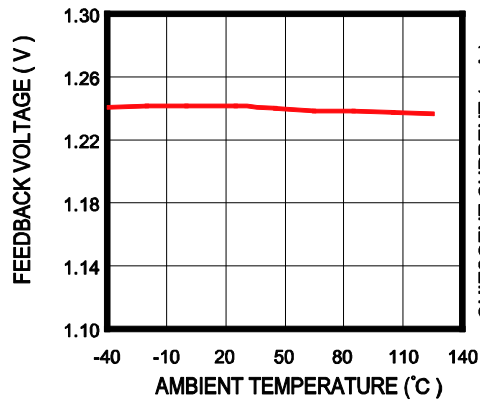
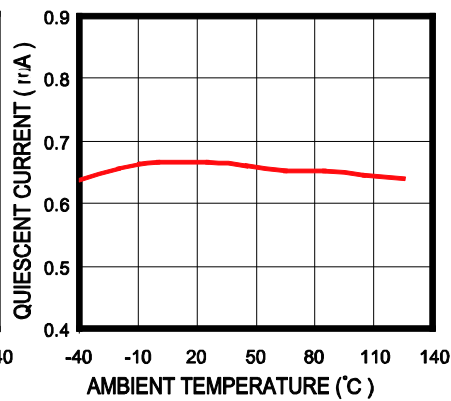
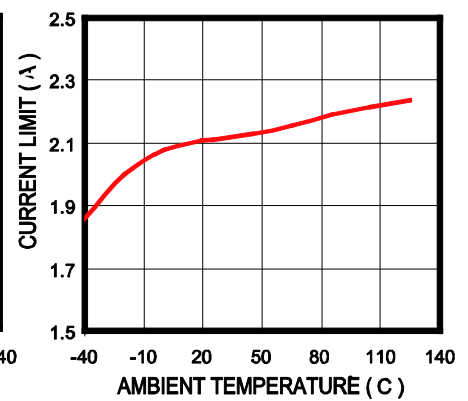
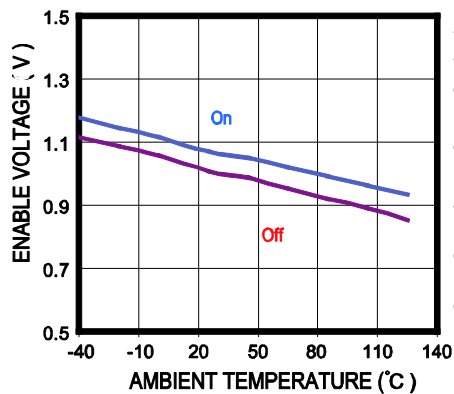
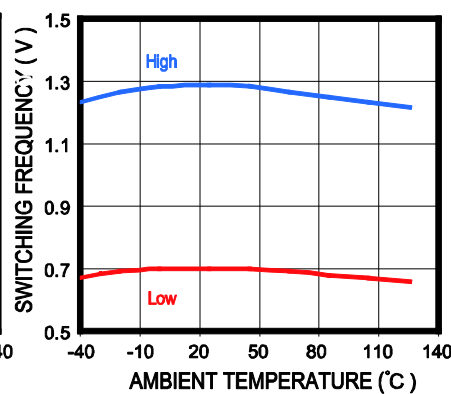
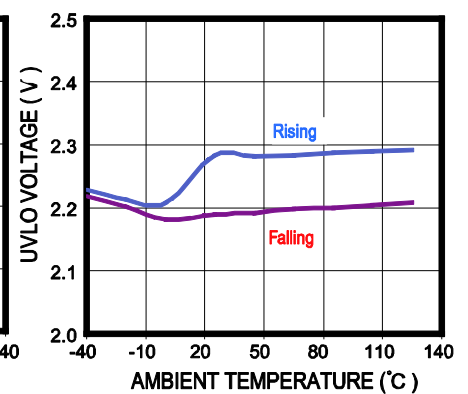
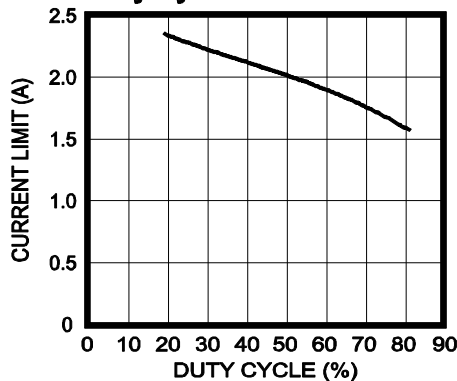
 **$V_{FB}$  Voltage vs.  $T_A$** 

**Quiescent Current vs.  $T_A$** 

**Current Limit vs.  $T_A$** 

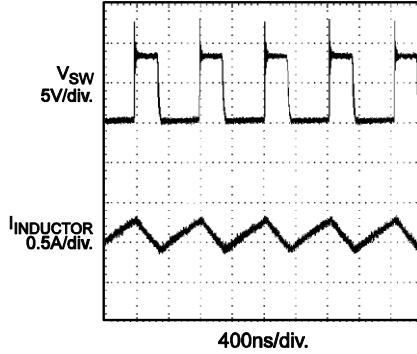
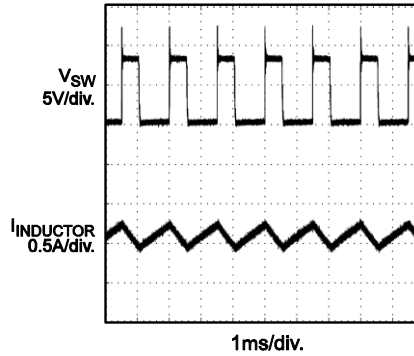
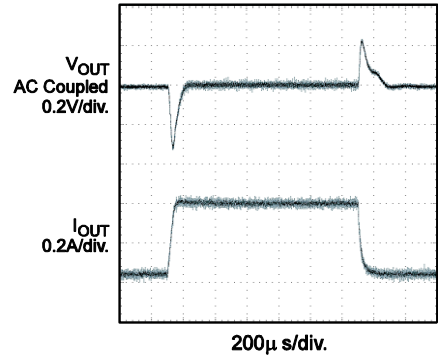
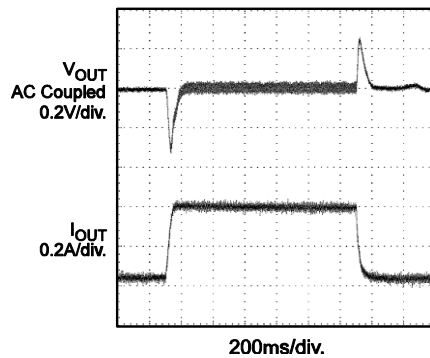
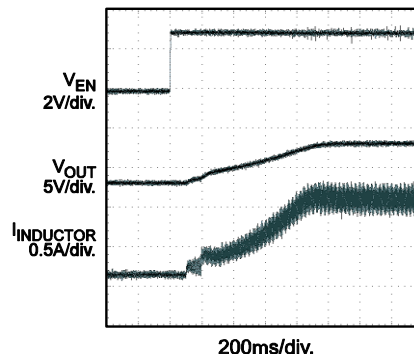
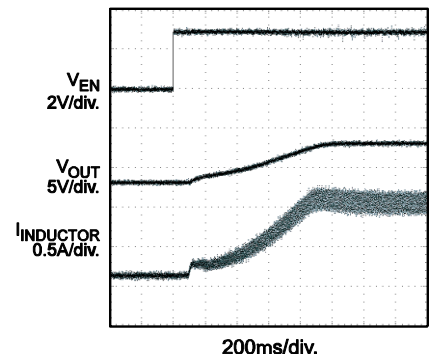
**Enable Voltage vs.  $T_A$** 

 **$F_{sw}$  Frequency vs.  $T_A$** 

**UVLO Voltage vs.  $T_A$** 

**Current Limit vs Duty Cycle**

**TYPICAL PERFORMANCE CHARACTERISTICS (continued)**

 Circuit on page 1,  $V_{IN} = 3.3V$ ,  $V_{OUT} = 8V$ , unless otherwise noted.

**Switching Waveform**
 $I_{OUT} = 400mA$ ,  $f_{SW} = 1.3MHz$ ,  
 $L = 4.7mH$ 

**Switching Waveform**
 $I_{OUT} = 400mA$ ,  $f_{SW} = 700kHz$ ,  
 $L = 10mH$ 

**Load Transient Response**
 $I_{OUT} = 40mA-400mA$ ,  $f_{SW} = 1.3MHz$ ,  
 $L = 4.7mH$ 

**Load Transient Response**
 $I_{OUT} = 40mA-400mA$ ,  $f_{SW} = 700kHz$ ,  
 $L = 10mH$ 

**Start-Up Waveform**
 $R_{OUT} = 20W$ ,  $f_{SW} = 1.3MHz$ ,  
 $L = 4.7mH$ 

**Start-Up Waveform**
 $R_{OUT} = 20W$ ,  $f_{SW} = 700kHz$ ,  
 $L = 10mH$ 

## PIN FUNCTIONS

Pin #	Name	Description
1	COMP	<b>Compensation.</b> Connect a capacitor and resistor in series from COMP to ground for loop stability.
2	FB	<b>Feedback input.</b> The reference voltage is 1.25V. Connect a resistor divider to FB.
3	EN	<b>Regulator on/off control input.</b> A high input at EN turns on the converter; a low input at EN turns off the converter. When not in use, connect EN to the input source through a 100kΩ pull-up resistor if $V_{IN} > 6V$ for automatic start-up. Do not leave EN floating.
4	GND	<b>Ground.</b>
5	SW	<b>Power switch output.</b> SW is the drain of the internal MOSFET switch. Connect the power inductor and output rectifier to SW. SW can swing between GND and 25V.
6	IN	<b>Input supply.</b> IN must be locally bypassed.
7	FSEL	<b>Frequency selection.</b> Tie FSEL to IN through a 100kΩ resistor if $V_{IN} > 6V$ for 1.3MHz operation, or tie FSEL to GND for 700kHz operation.
8	SS	<b>Soft-start control.</b> Connect a soft-start capacitor to SS. The soft-start capacitor is charged with a constant 6μA current.



### BLOCK DIAGRAM

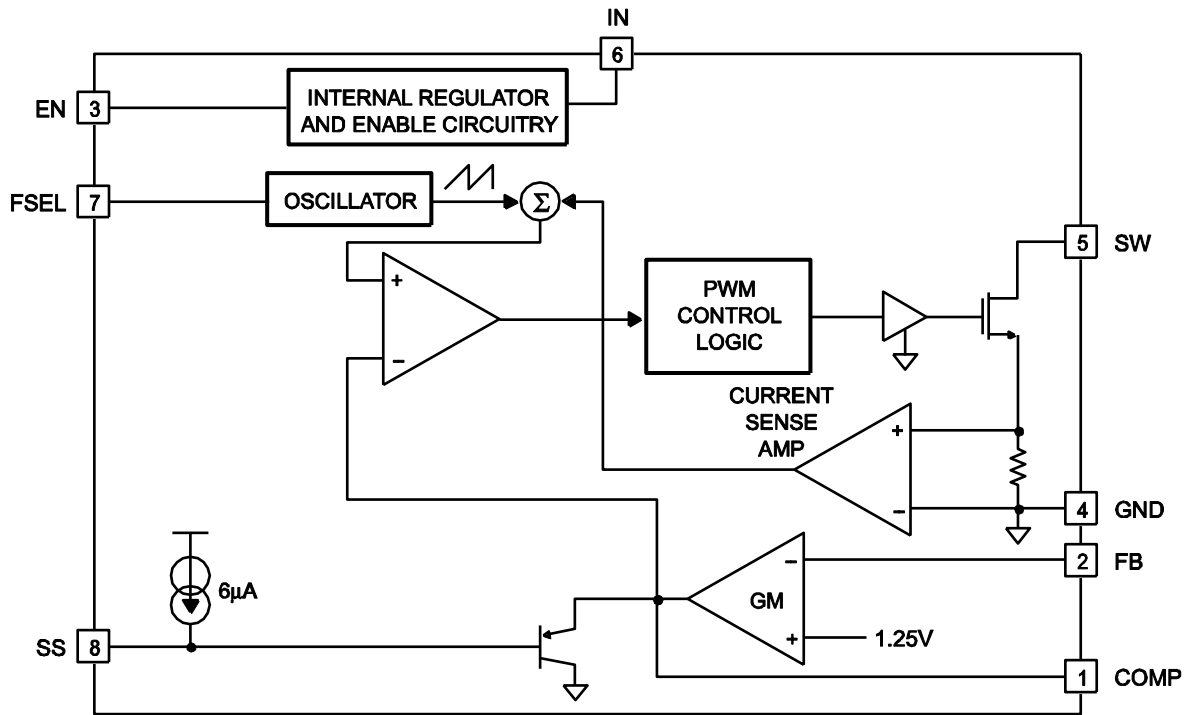

Figure 1: Functional Block Diagram

## OPERATION

The MPQ1542 uses a constant frequency, peak-current mode, boost regulation architecture to regulate the feedback voltage.

The operation of the MPQ1542 is shown in the block diagram on page 9.

At the beginning of each cycle, the N-channel MOSFET switch is turned on, forcing the inductor current to rise. The current at the source of the switch is measured internally and converted to a voltage by the current sense amplifier. This voltage is compared to the error voltage at COMP. The voltage at the output of the error amplifier is an amplified version of the difference between the 1.25V reference voltage and the feedback voltage. When these two voltages are equal, the PWM comparator turns off the switch, forcing the inductor current to the output capacitor through the external rectifier. This causes the inductor current to decrease. The peak inductor current is controlled by the voltage at COMP, which is controlled by the output voltage. Therefore, the output voltage controls the inductor current to satisfy the load. The use of current mode regulation improves transient response and control loop stability.

## APPLICATION INFORMATION

All components referenced below apply to the Typical Application circuit on page 1.

### Selecting the Soft-Start (SS) Capacitor

The MPQ1542 includes a soft-start (SS) timer that limits the voltage at COMP during start-up to prevent excessive current at the input. This prevents premature termination of the source voltage at start-up due to an input current overshoot. When power is applied to the MPQ1542, and enable is asserted, a 6µA internal current source charges the external capacitor at SS. As the SS capacitor is charged, the voltage at SS rises. The MPQ1542 clamps the voltage at COMP internally to 700mV above the voltage at SS. The soft start ends when the voltage at SS reaches 0.45V. This limits the inductor current at start-up, forcing the input current to rise slowly to the current required to regulate the output voltage.

The soft-start period can be determined by Equation (1):

$$t_{SS} = 75 \times C_{SS} \quad (1)$$

Where  $C_{SS}$  is the soft-start capacitor from SS to GND (in nF), and  $t_{SS}$  is the soft-start period (in µs).

The capacitor required for a given soft-start period can be determined by Equation (2):

$$C_{SS} = 0.0133 \times t_{SS} \quad (2)$$

### Setting the Output Voltage

Set the output voltage by selecting the resistive voltage divider ratio. Use 10kΩ for the low-side resistor (R2) of the voltage divider. Determine the high-side resistor (R1) with Equation (3):

$$R1 = \frac{R2(V_{OUT} - V_{FB})}{V_{FB}} \quad (3)$$

Where  $V_{OUT}$  is the output voltage. For  $R2 = 10k\Omega$  and  $V_{FB} = 1.25V$ , then  $R1$  (kΩ) =  $8k\Omega$  ( $V_{OUT} - 1.25V$ ).

### Selecting the Input Capacitor

An input capacitor is required to supply AC ripple current to the inductor while limiting noise at the input source. A low ESR capacitor is required to keep the noise at the IC to a minimum. Ceramic capacitors are preferred, but tantalum or low ESR electrolytic capacitors are also sufficient.

Use an input capacitor with a value greater than 4.7µF. The capacitor can be electrolytic, tantalum, or ceramic. However, since it absorbs the input switching current, it requires an adequate ripple current rating. Use a capacitor with an RMS current rating greater than the inductor ripple current to determine the inductor ripple current (see the Selecting the Inductor section on page 12 for details).

To ensure stable operation, place the input capacitor as close to the IC as possible. Alternately, a smaller, high-quality, 0.1µF ceramic capacitor may be placed closer to the IC with the larger capacitor placed further away. If using this technique, it is recommended that the larger capacitor be tantalum or electrolytic. All ceramic capacitors should be placed close to the MPQ1542.

### Selecting the Output Capacitor

The output capacitor is required to maintain the DC output voltage. Low ESR capacitors are recommended to keep the output voltage ripple minimal. The characteristics of the output capacitor also affects the stability of the regulation control system. Ceramic, tantalum, or low ESR electrolytic capacitors are recommended. In the case of ceramic capacitors, the impedance of the capacitor at the switching frequency is dominated by the capacitance, so the output voltage ripple is mostly independent of the ESR. The output voltage ripple can be estimated with Equation (4):

$$V_{RIPPLE} \approx \frac{\left(1 - \frac{V_{IN}}{V_{OUT}}\right) \times I_{LOAD}}{C2 \times f_{SW}} \quad (4)$$

Where  $V_{RIPPLE}$  is the output ripple voltage,  $V_{IN}$  is the DC input voltage,  $V_{OUT}$  is the DC output voltage,  $I_{LOAD}$  is the load current,  $f_{SW}$  is the switching frequency, and  $C2$  is the capacitance of the output capacitor.

In the case of tantalum or low ESR electrolytic capacitors, the ESR dominates the impedance at the switching frequency. The output ripple can be calculated with Equation (5):

$$V_{\text{RIPPLE}} \approx \frac{(1 - \frac{V_{\text{IN}}}{V_{\text{OUT}}}) \times I_{\text{LOAD}}}{C2 \times f_{\text{SW}}} + \frac{I_{\text{LOAD}} \times R_{\text{ESR}} \times V_{\text{OUT}}}{V_{\text{IN}}} \quad (5)$$

Where  $R_{\text{ESR}}$  is the equivalent series resistance of the output capacitors.

Choose an output capacitor to satisfy the output ripple and load transient requirements of the design. A 4.7 $\mu\text{F}$  - 22 $\mu\text{F}$  ceramic capacitor is suitable for most applications.

### Selecting the Inductor

The inductor is required to force the higher output voltage while being driven by the input voltage. A larger value inductor results in less ripple current that results in a lower peak inductor current, reducing stress on the internal N-channel switch. However, the larger inductor also has a larger physical size, higher series resistance, and lower saturation current.

A 4.7 $\mu\text{H}$  inductor is recommended for most 1.3MHz applications, and a 10 $\mu\text{H}$  inductor is recommended for most 700kHz applications. However, a more exact inductance value can be calculated. It is recommended to allow the peak-to-peak ripple current to be approximately 30-50% of the maximum input current. Ensure that the peak inductor current is below 75% of the current limit at the operating duty cycle to prevent regulation loss due to the current limit. Also ensure that the inductor does not saturate under the worst-case load transient and start-up conditions. Calculate the required inductance value with Equation (6), Equation (7), and Equation (8):

$$L = \frac{V_{\text{IN}} \times (V_{\text{OUT}} - V_{\text{IN}})}{V_{\text{OUT}} \times f_{\text{SW}} \times \Delta I} \quad (6)$$

$$I_{\text{IN(MAX)}} = \frac{V_{\text{OUT}} \times I_{\text{LOAD(MAX)}}}{V_{\text{IN}} \times \eta} \quad (7)$$

$$\Delta I = (30\% - 50\%) I_{\text{IN(MAX)}} \quad (8)$$

Where  $I_{\text{LOAD(MAX)}}$  is the maximum load current,  $\Delta I$  is the peak-to-peak inductor ripple current, and  $\eta$  is the efficiency.

### Selecting the Diode

The output rectifier diode supplies current to the inductor when the internal MOSFET is off. To reduce losses due to the diode forward voltage and recovery time, use a Schottky diode with the MPQ1542. The diode should be rated for a reverse voltage equal to or greater than the output voltage used. The average current rating must be greater than the maximum load current expected, and the peak current rating must be greater than the peak inductor current.

### Compensation

The output of the transconductance error amplifier (COMP) is used to compensate for the regulation control system. The system uses two poles and one zero to stabilize the control loop. The pole  $f_{P1}$  is set by the output capacitor (C2) and load resistance, and  $f_{P2}$  is set by the compensation capacitor (C3). The zero ( $f_{Z1}$ ) is set by the compensation capacitor (C3) and the compensation resistor (R3). The poles and zero can be determined with Equation (9), Equation (10), and Equation (11):

$$f_{P1} = \frac{1}{\pi \times C2 \times R_{\text{LOAD}}} \quad (9)$$

$$f_{P2} = \frac{G_{\text{EA}}}{2 \times \pi \times C3 \times A_{\text{VEA}}} \quad (10)$$

$$f_{Z1} = \frac{1}{2 \times \pi \times C3 \times R3} \quad (11)$$

Where  $R_{\text{LOAD}}$  is the load resistance,  $G_{\text{EA}}$  is the error amplifier transconductance, and  $A_{\text{VEA}}$  is the error amplifier voltage gain.

The DC loop gain can be calculated with Equation (12):

$$A_{\text{VDC}} = \frac{1.5 \times A_{\text{VEA}} \times V_{\text{IN}} \times R_{\text{LOAD}} \times V_{\text{FB}}}{V_{\text{OUT}}^2} \quad (12)$$

Where  $V_{\text{FB}}$  is the feedback regulation threshold.

There is also a right-half-plane zero ( $f_{\text{RHPZ}}$ ) that exists in continuous conduction mode step-up converters, where the inductor current does not drop to zero on each cycle. The frequency of the right-half-plane zero can be calculated with Equation (13):

$$f_{\text{RHPZ}} = \frac{V_{\text{IN}}^2 \times R_{\text{LOAD}}}{2 \times \pi \times L \times V_{\text{OUT}}^2} \quad (13)$$

Table 1 lists generally recommended compensation components for the different input voltages, output voltages, and capacitance values of the most frequently used output ceramic capacitors. Since ceramic capacitors have extremely low ESR, a second compensation capacitor (from COMP to GND) is not required.

**Table 1: Component Selection**

V <sub>IN</sub> (V)	V <sub>OUT</sub> (V)	C2 (μF)	R3 (kΩ)	C3 (nF)
3.3	8	4.7	10	2.2
3.3	8	10	10	2.2
3.3	8	22	10	2.2
3.3	12	4.7	15	1
3.3	12	10	15	1
3.3	12	22	15	2.2
3.3	18	4.7	20	1
3.3	18	10	20	1
3.3	18	22	30	2.2
5	8	4.7	10	4.7
5	8	10	10	4.7
5	8	22	15	1
5	12	4.7	15	2.2
5	12	10	15	2.2
5	12	22	20	1
5	18	4.7	20	1
5	18	10	20	1
5	18	22	30	1
12	15	4.7	10	2.2
12	15	10	10	2.2
12	15	22	15	1
12	18	4.7	5.1	2.2
12	18	10	5.1	2.2
12	18	22	15	1

For a faster control loop and better transient response, set the capacitor (C3) to the recommended value in Table 1. Then slowly increase the resistor (R3) and check the load step response on a bench to ensure that the ringing and overshoot on the output voltage at the edge of the load steps is minimal.

Finally, the compensation needs to be checked by calculating the DC loop gain and the crossover frequency. The crossover frequency where the loop gain drops to 0dB or a gain of 1 can be obtained visually by placing a -20dB/decade slope at each pole and a +20dB/decade slope at each zero. The crossover frequency should be at least one decade below the frequency of the right-half-plane zero at the maximum output load current to obtain a high enough phase margin for stability.

### AMLCD Applications

Figure 3 shows a power supply for active matrix (TFT - LCD) flat-panel displays. The positive and negative charge pump outputs are configured with discrete components. Adjust the output capacitance and compensation component values as necessary to meet the transient performance.

### PCB Layout Guidelines

Efficient PCB layout, especially regarding the high-frequency switching regulators, is critical for stable operation and low noise. For best results, follow the guidelines below.

1. Place all components as close to the IC as possible.
2. Keep the path between SW, the output diode, output capacitor, and GND extremely short for minimal noise and ringing.
3. Place the input capacitor close to IN for optimal decoupling.
4. Keep all feedback components close to FB to prevent noise injection on the FB trace.
5. Tie the ground return of the input and output capacitors close to GND.

See the MPQ1542 demo board layout for reference.

## TYPICAL APPLICATION CIRCUITS

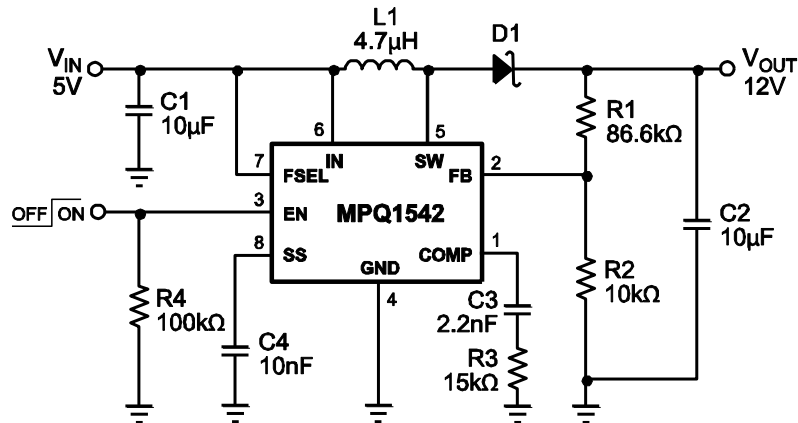

Figure 2: Typical Application Circuit

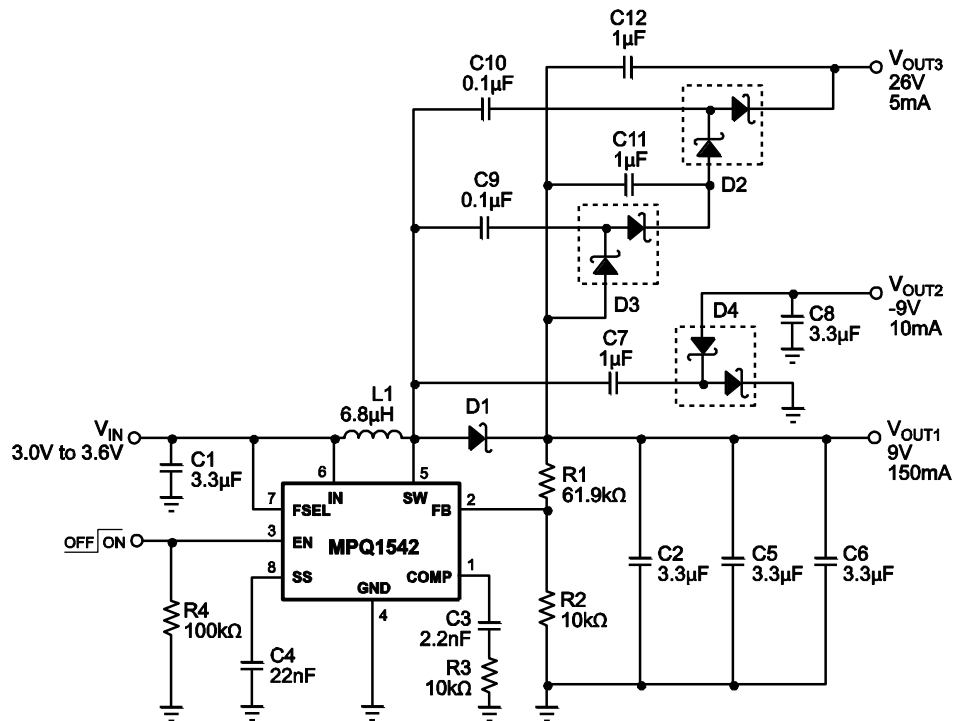
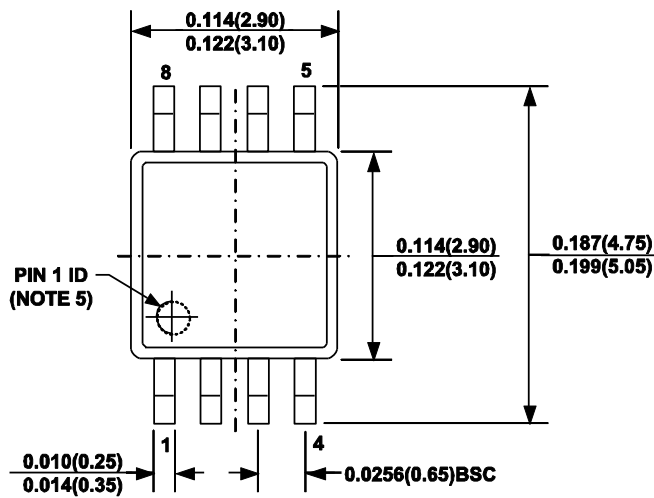

Figure 3: Multiple Output, Low-Profile (1.2mm Max) TFT - LCD Power Supply

## PACKAGE INFORMATION

### MSOP-8



**TOP VIEW**

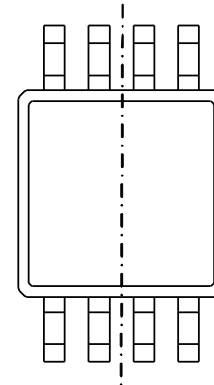

**BOTTOM VIEW**

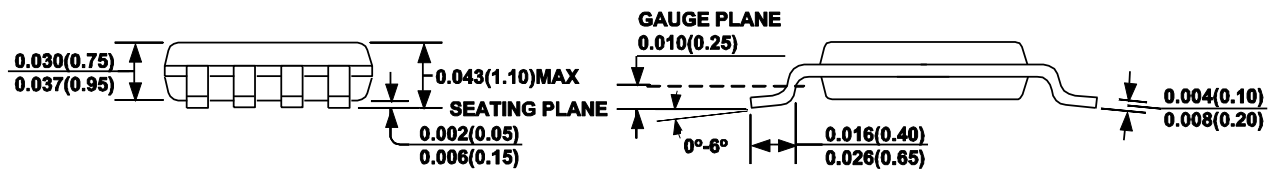

**FRONT VIEW**

**SIDE VIEW**

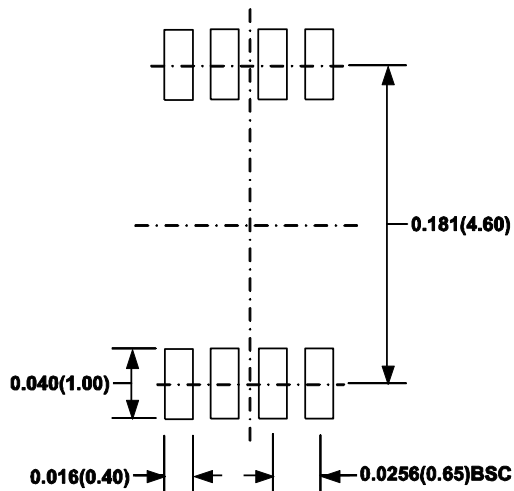

**RECOMMENDED LAND PATTERN**

#### NOTE:

- 1) CONTROL DIMENSION IS IN INCHES. DIMENSION IN BRACKET IS IN MILLIMETERS.
- 2) PACKAGE LENGTH DOES NOT INCLUDE MOLD FLASH, PROTRUSION OR GATE BURR.
- 3) PACKAGE WIDTH DOES NOT INCLUDE INTERLEAD FLASH OR PROTRUSION.
- 4) LEAD COPLANARITY (BOTTOM OF LEADS AFTER FORMING) SHALL BE 0.004" INCHES MAX.
- 5) PIN 1 IDENTIFICATION HAS HALF OR FULL CIRCLE OPTION.
- 6) DRAWING MEETS JEDEC MO-187, VARIATION AA.
- 7) DRAWING IS NOT TO SCALE.

**NOTICE:** The information in this document is subject to change without notice. Users should warrant and guarantee that third party Intellectual Property rights are not infringed upon when integrating MPS products into any application. MPS will not assume any legal responsibility for any said applications.