



ANATECH ELECTRONICS INC
RF & Microwave Filters & Products

250 MHz LC Bandpass Filter

Part Number: AE250B10572



Electrical specifications

Center Frequency: 250 MHz
3 dB Bandwidth: Approx. 300 MHz
Insertion Loss: 1.0 dB Max
Return Loss: 15 dB Min @ ± 125 MHz
Rejection: <-40 dB @ 1000 MHz
Rejection 2: <-50 dB @ 2500 MHz
Input / Output Impedance: 50 Ohms

Mechanical

Connector Type: SMA (F)
Dimensions: 2.38 x 1 x 1 inches

Environmental

Operating Temperature: -45 to +85 deg.C
Storage Temperature: -55 to +95 deg.C
Shock: 10 G. 11ms
Vibration: 10 G. 5 to 200 Hz

Outline Drawing:

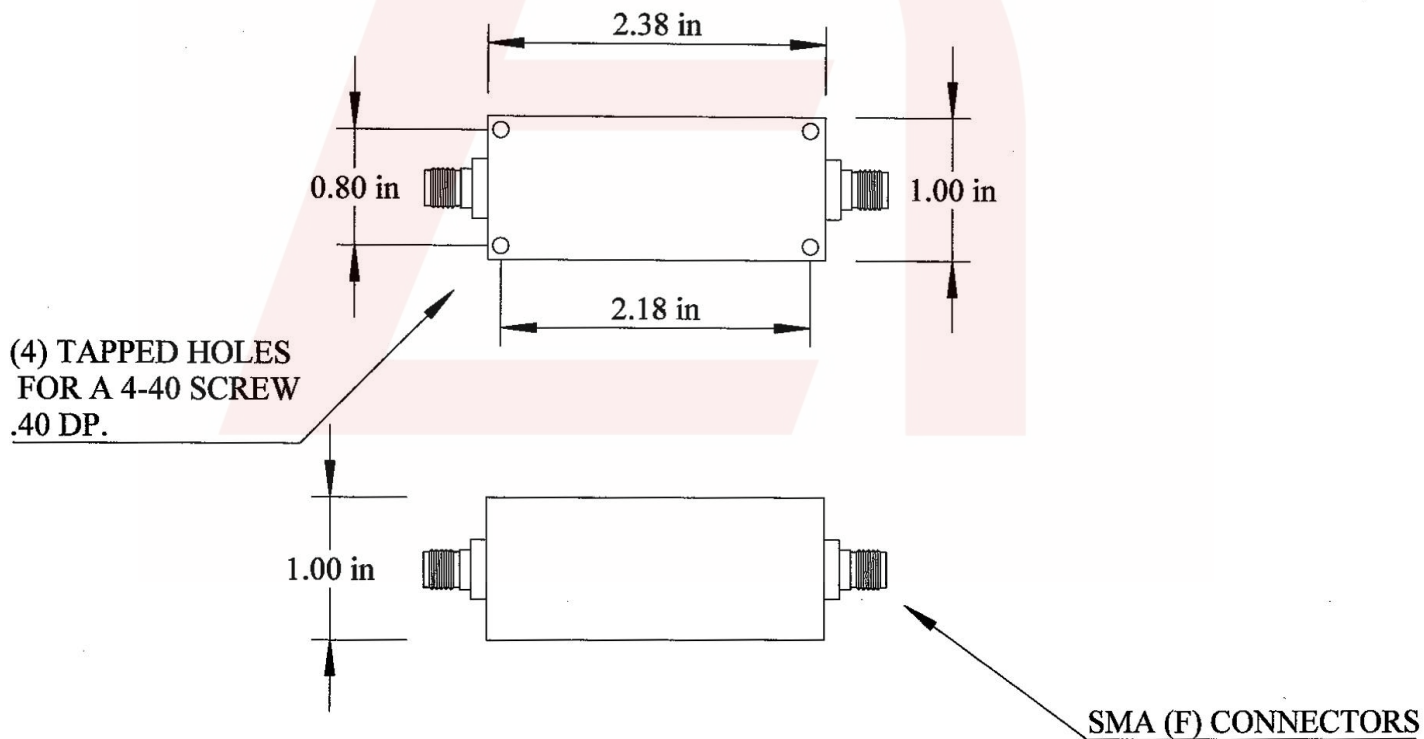

DS-B10572-02092015-Rev0



ANATECH ELECTRONICS INC
RF & Microwave Filters & Products

250 MHz LC Bandpass Filter

Part Number: AE250B10572



Response Plot:

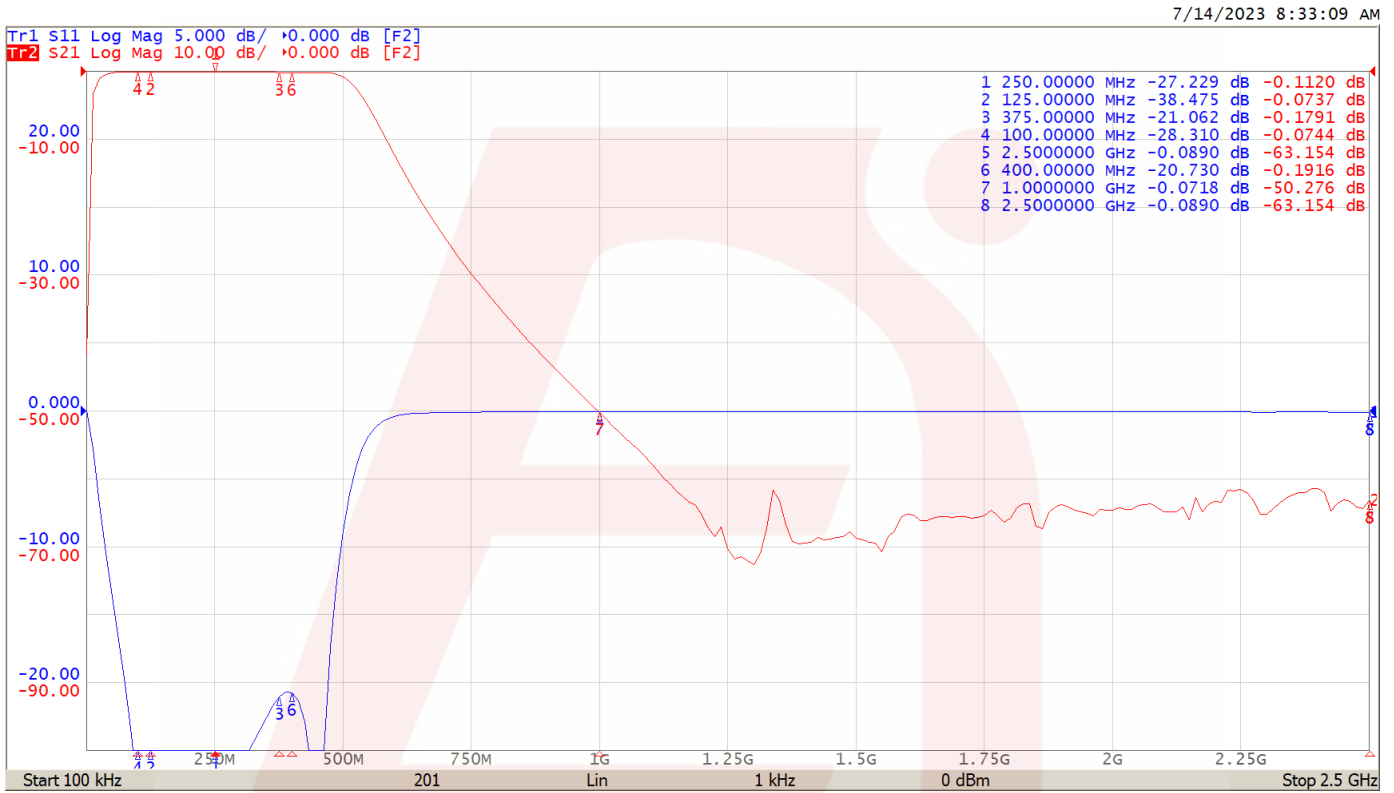

DS-B10572-02092015-Rev0