



The Future of Analog IC Technology®

MP3352

60V, 2.5A Integrated Photo Flash Charger with IGBT Driver and Quench

DESCRIPTION

The MP3352 is a fast, highly efficient, precision high-voltage photo-flash charger with integrated IGBT driver for xenon flash applications. The programmable peak current is up to 2.5A to ensure fast charging time. A 200mΩ internal power switch minimizes the conduction loss. In addition, a 60V maximum voltage lowers the transformer turns ratio and improves the switching loss associated with the primary leakage inductance. External feedback provides 3% charge accuracy.

The MP3352 is available in a 16-pin 3mm x 3mm QFN package.

FEATURES

- Integrated 60V, 200mΩ Power Switch
- Programmable Peak Current Up to 2.5A
- 3% Charge Accuracy
- <1uA Shutdown Current
- Integrated IGBT Driver
- Integrated Quench Feature

APPLICATIONS

- Digital Still Cameras
- Optical Film Cameras
- Mobile Phones With Camera
- PDAs With Camera

"MPS" and "The Future of Analog IC Technology" are Registered Trademarks of Monolithic Power Systems, Inc.

TYPICAL APPLICATION

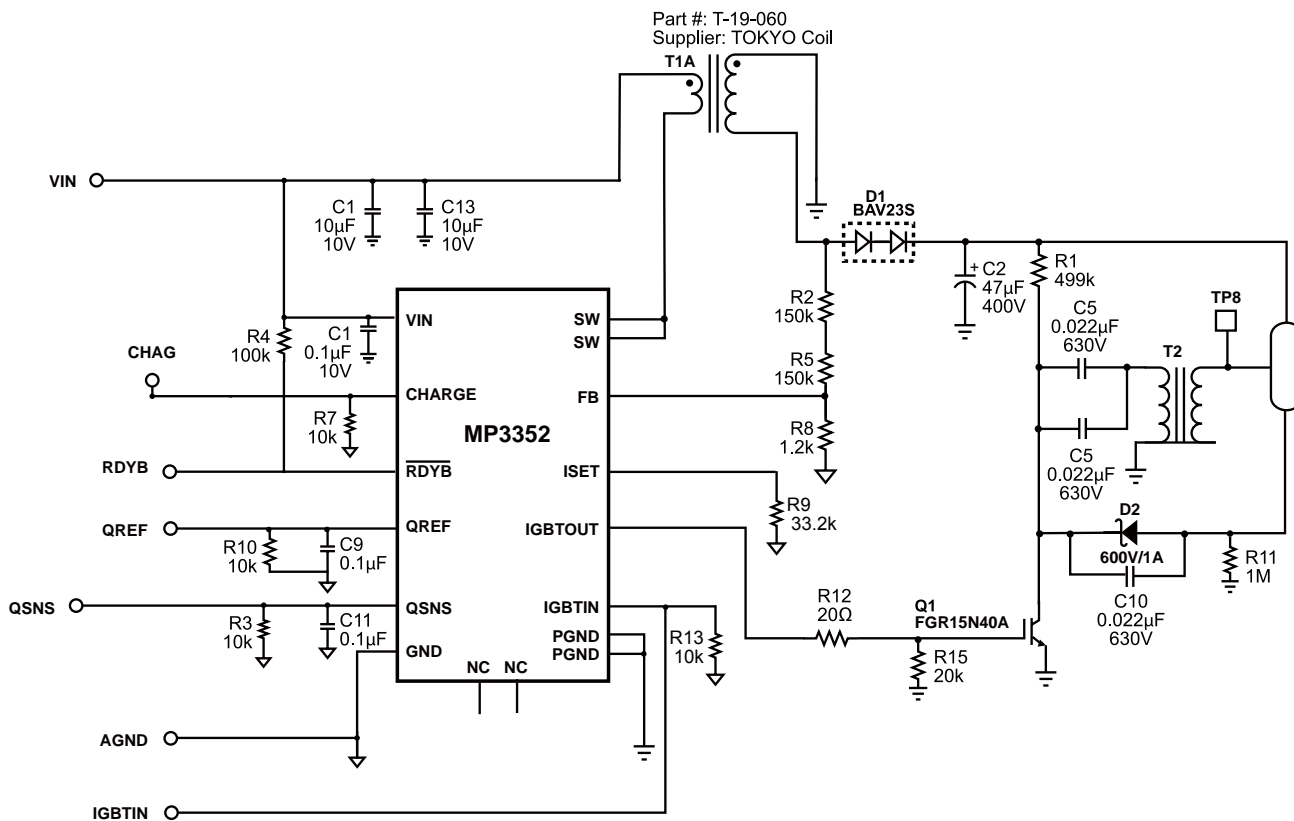

PACKAGE REFERENCE

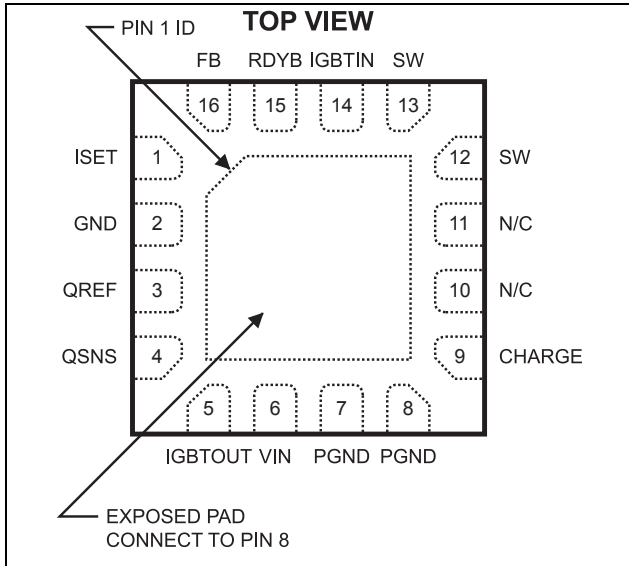

Part Number*	Package	Temperature
MP3352DQ	QFN16-3	-40°C to +85°C

* For Tape & Reel, add suffix -Z (e.g. MP3352DQ-Z)
 For RoHS compliant packaging, add suffix -LF (e.g. MP3352DQ-LF-Z)

ABSOLUTE MAXIMUM RATINGS ⁽¹⁾

V_{IN} to GND -0.3V to 6V
 CHARGE, ISET, IGBTIN, RDYB, QREF, QSNS to GND -0.3V to 6V
 FB to GND -0.3V to 6V
 SW to GND -0.3V to 60V
 Maximum Operating Frequency 400kHz
 Operating Temperature Ranges: -40°C to +85°C
 Storage Temperature -55°C to +150°C
 Junction Temperature +150°C
 Lead Temperature (Solder) +260°C

Thermal Resistance ⁽²⁾ θ_{JA} θ_{JC}
 QFN16 (3mmx3mm) 50 12... °C/W

Notes:

- 1) Exceeding these ratings may damage the device.
- 2) Measured on approximately 1" square of 1 oz copper.

ELECTRICAL CHARACTERISTICS

($V_{IN}=V(CHARGE)=3.3V$, $T_A = +25^\circ C$, unless otherwise noted.)

Parameter	Conditions	Min	Typ	Max	Unit
Photoflash Capacitor Charger					
V_{IN} Voltage Range		3		6	V
V_{IN} UVLO	Rising edge, hysteresis = 200mV	2.7	2.8	2.9	V
V_{IN} Quiescent Current	$V(CHARGE)=High$, $V(SW) = 0$, free run by T_{ONMAX}		1	2	mA
V_{IN} Quiescent Current	Charge Complete, $V(CHARGE)=High$, $V(FB) = 1.3V$		50		μA
Shutdown Current from V_{IN}	$V(CHARGE)=Low$			1	μA
V_{SW} Leakage Current	$V_{IN}=3.3V$, $V_{SW}=60V$, in Shutdown			2	μA
SW ON resistance between SW and GND	Switch turn-on		0.2		Ω
Charge Input High Voltage		2.4			V
Charge Input Low Voltage				0.6	V
Pull-down resistance of CHARGE pin	$V(CHARGE)=3.3V$		100K		Ω
I_{PEAK1}	$R_{SET}=33.2k\Omega$	1.36	1.51	1.66	A
I_{PEAK2}	$R_{SET}=100k\Omega$	0.4	0.5	0.6	A
Charge completion detect voltage at FB		1.176	1.20	1.224	V
FB input bias current I(FB)		-0.2		0.2	μA
DCM Comparator threshold	With 1.2K Ω (1%) connected to FB	15	25	35	mV

ELECTRICAL CHARACTERISTICS *(continued)*

 ($V_{IN}=V(CHARGE)=3.3V$, $T_A = +25^{\circ}C$, unless otherwise noted.)

Parameter	Conditions	Min	Typ	Max	Unit
RDYB Leakage Current	$V(RDYB)=3.3V$			1	μA
RDYB Output Low Voltage	$I_{SINK} = 2mA$		0.2		V
MAX T_{ON}	Maximum T_{ON} time	45	75	105	μs
Thermal Shutdown	Rising edge, hysteresis = $15^{\circ}C$		150		$^{\circ}C$
QREF input current	$Q_{REF}=0.2V$ to $1.2V$	-0.1		0.1	μA
QSNS-QREF offset voltage	$Q_{REF}=0.2V$ to $1.2V$	-50		50	mV
QSNS input current	$Q_{REF}=0.2V$ to $1.2V$	-0.1		0.1	μA
QSNS to IGBT Delay	$Q_{REF}=0.2V$ to $1.2V$		2		μs
IGBT Driver					
IGBTOUT pull-up ON resistance			5		Ω
IGBTOUT pull-down ON resistance			5		Ω
IGBTIN Input High Voltage		2.4			V
IGBTIN Input Low Voltage				0.6	V
Propagation delay	IGBTIN rising/falling edge to IGBTOUT rising/falling edge, $C_{GATE}=6500pF$		45		ns
IGBTOUT rise time	$C_{GATE}=6500pF, 20\%$ to 80%		60		ns
IGBTOUT fall time	$C_{GATE}=6500pF, 20\%$ to 80%		70		ns
Pull down resistance of IGBTIN			100K		Ω

PIN FUNCTIONS

Pin #	Name	Function
1	ISET	Peak Current Set Input. The peak current is 5×10^4 the current flow out of this pin.
2	GND	Analog Ground. Tie it directly to local ground plane.
3	QREF	Quench reference input.
4	QSNS	Quench sense input from light sensor.
5	IGBTOUT	Output Drive for IGBT Gate. Connect this pin to the gate of the IGBT.
6	VIN	Input Supply Pin. Connect it to system supply voltage. Bypass VIN to GND with a $2 \times 10 \mu F$ or greater ceramic capacitor.
7, 8	PGND	Power Ground. Ground connection for the power switch.
9	CHARGE	Charge Enable Pin. A low-to-high transition on this pin puts the part into power delivery mode. Once the target voltage is reached, the part will stop charging the output. Toggle this pin will start charging again. Bring this pin low will terminate the power delivery and put the part in shutdown.
10, 11	N/C	No Connect
12, 13	SW	Switch Pin. This is the drain of the internal power switch.
14	IGBTIN	Logic Input Pin for IGBT Drive.
15	RDYB	Open-Drain Power-Ready Output. RDYB goes low when the output voltage is reached.
16	FB	Feedback Pin. Trip voltage is $1.2V$.

TYPICAL PERFORMANCE CHARACTERISTICS

$T_A = +25^\circ\text{C}$, unless otherwise noted.

Switching Waveform

$V_{CC}=V_{IN}=3.3\text{V}, V_{OUT}=300\text{V}, I_{SET}=2.5\text{A}$

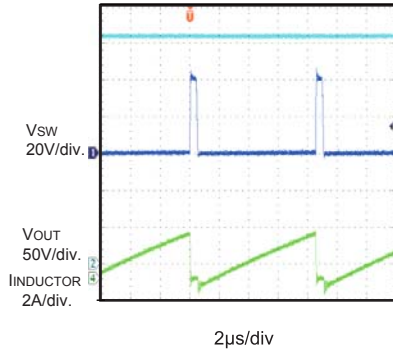

Switching Waveform

$V_{CC}=V_{IN}=5\text{V}, V_{OUT}=300\text{V}, I_{SET}=2.5\text{A}$

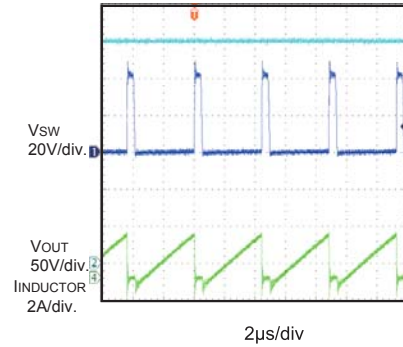

Charging Waveform

$C_{OUT}=47\mu\text{F}, V_{CC}=V_{IN}=3.3\text{V}, V_{OUT}=300\text{V}, I_{SET}=2.5\text{A}$

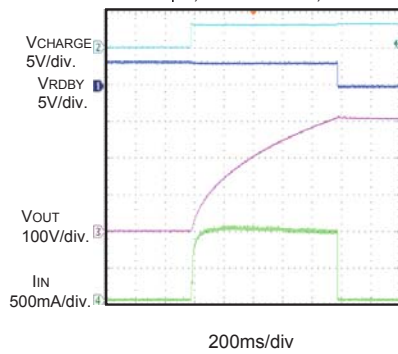

Charging Waveform

$C_{OUT}=100\mu\text{F}, V_{CC}=V_{IN}=3.3\text{V}, V_{OUT}=300\text{V}, I_{SET}=2.5\text{A}$

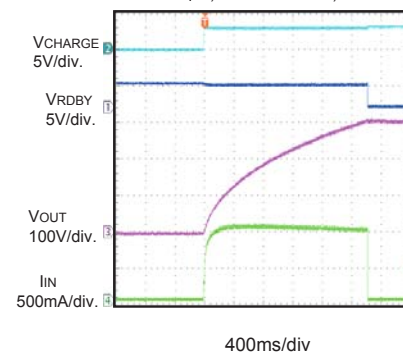

Charging Waveform

$C_{OUT}=47\mu\text{F}, V_{CC}=V_{IN}=5\text{V}, V_{OUT}=300\text{V}, I_{SET}=2.5\text{A}$

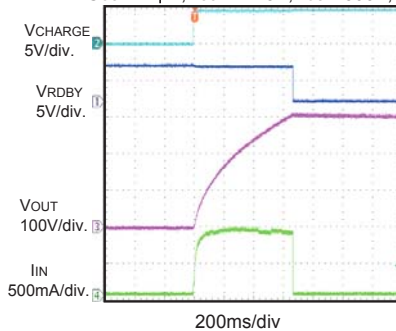

Charging Waveform

$C_{OUT}=100\mu\text{F}, V_{CC}=V_{IN}=5\text{V}, V_{OUT}=300\text{V}, I_{SET}=2.5\text{A}$

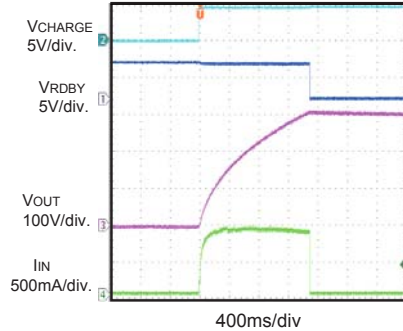

TYPICAL PERFORMANCE CHARACTERISTICS *(continued)*

$T_A = +25^\circ\text{C}$, unless otherwise noted.

Charge time vs. Input Voltage

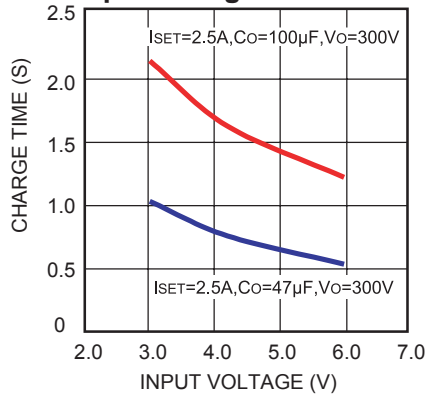

Efficiency at $I_{SET}=2.5A$

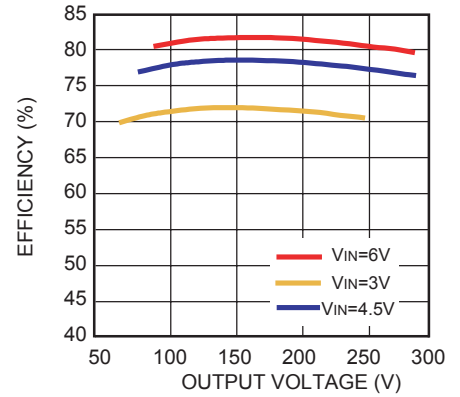

Line Regulation (%)

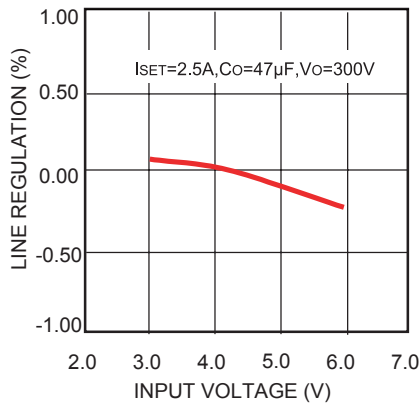

V_{OUT} vs. V_{IN}

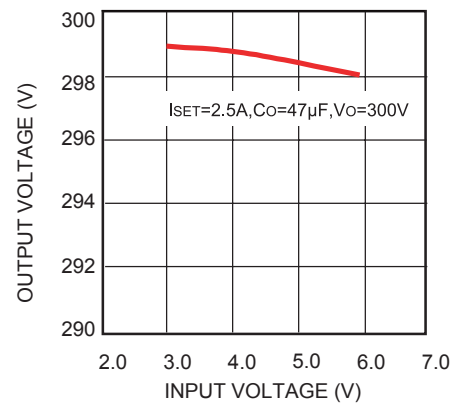

Flash Current

$V_{OUT}=300V$

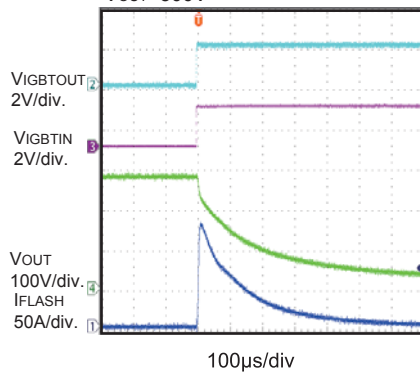

TEST CIRCUITS

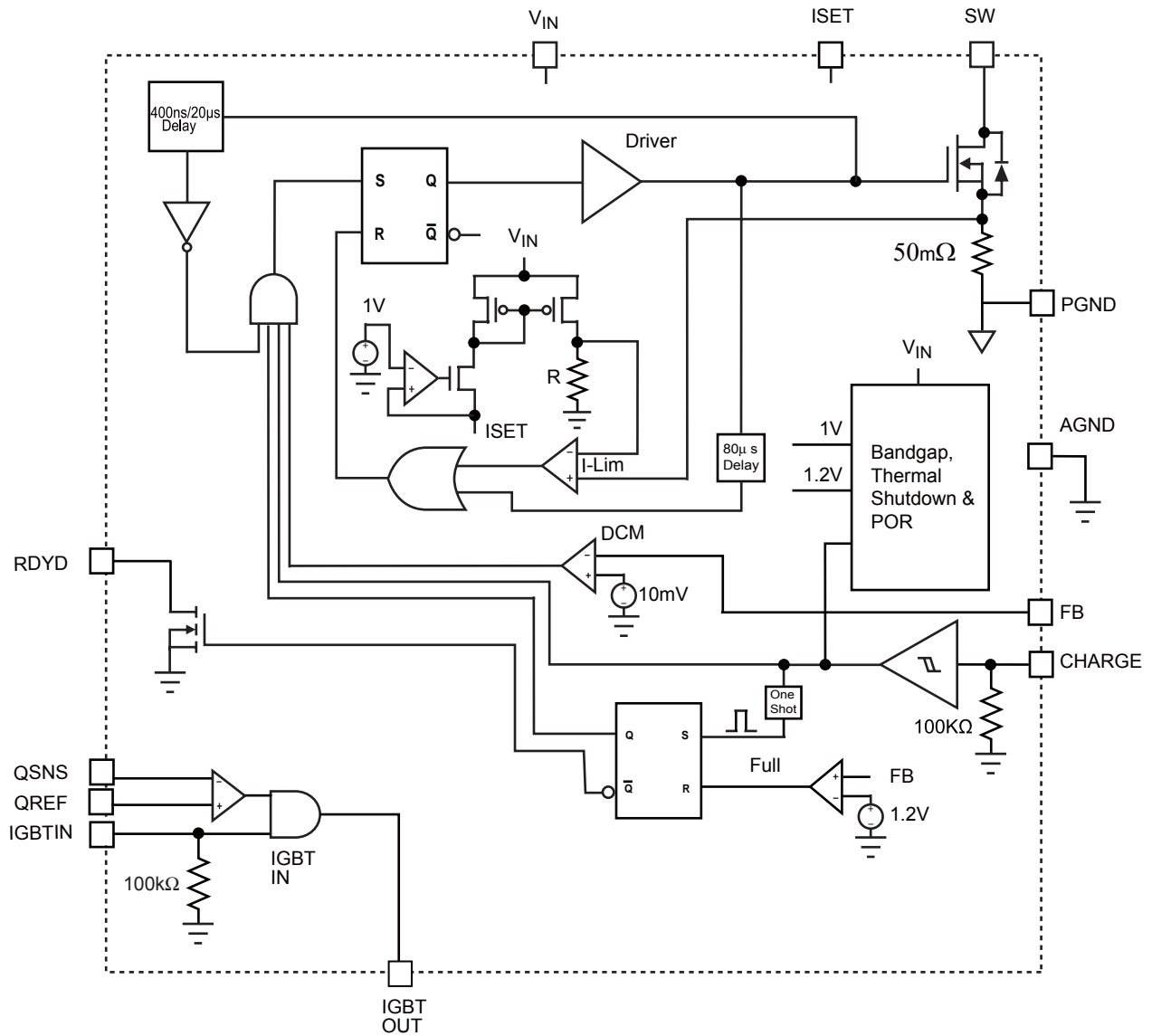

Figure 1—Functional Block Diagram

APPLICATION INFORMATION

MP3352 controlled flyback charger operates in critical conduction mode with peak current set by ISET pin. Output voltage is divided down through R1, R2 from the positive terminal of the transformer secondary and compares with 1.20V at FB pin. The low to high transition of CHARGE pin will enable the flyback converter to switch.

Charger may enter DCM mode when charge is close to full and actual OFF time is less than minimum T_{OFF} . Circuit will stop switching and RDYB will be pulled low once the flash capacitor is charged to 300V, a value set by R2, R5, and R8. When the part is ready the internal dissipation is reduced to just the circuits for IGBT driver. Toggle CHARGE pin will start charge again. Bringing CHARGE pin low terminates the power delivery and put the part in shutdown. A maximum T_{ON} timer prevents pulling current from starved power source. If the ON time exceeds maximum T_{ON} , the switch is forced OFF regardless of I_{PEAK} detection. Integrated IGBT driver uses V_{IN} as its power supply.

DCM Comparator

DCM boundary is reached when V (FB) drops to zero. The DCM comparator compares V (FB) and a fixed offset voltage of 25mV to account for the comparator delay.

Charge Speed

The output capacitor charging speed is determined by:

$$T_{charge} \propto \frac{I_{LIM}}{\frac{1}{V_{IN}} + \frac{N}{V_{OUT}}}$$

Setting Peak Charge Current

MP3352's peak charge current (I_{SET}) can be set by an external resistor, R_{SET} from the ISET pin to ground. The value of R_{SET} can be calculated from:

$$R_{SET} (K\Omega) = \frac{50}{I_{SET} (A)}$$

For example, for 2.5A peak charge current, R_{SET} is 20k Ω .

Primary Inductance

The primary inductance is calculated based on the minimum off time period:

$$L_{primary} \geq \frac{V_{out} T_{min,off}}{N I_{peak}}$$

V_{OUT} : output voltage about 300V

$T_{MIN-OFF}$ Minimum off time 300ns.

I_{PEAK} : primary peak current

Turns Ratio

The minimum turns ratio of the flyback transformer is obtained as:

$$N \geq \frac{V_{out}}{V_{ds} - V_{in}}$$

V_{DS} : FET drain-source voltage

V_{IN} : Input voltage 3~5V

Table 1—Recommended Transformer Table

Part Number	Description	Size (LxWxH)	Vendor
TTRN-038S T-19-060	1:8, L _{primary} = 6 μ H, for I_{LIM} = 2.5 A _{max}	6.4mm×7.7mm×4.0mm	TOKYO Coil
750310448	1:8, L _{primary} = 6 μ H, for I_{LIM} = 2.5 A _{max}	7mm×10mm×5mm	Würth Electronics
LDT565630T-042	1:8, L _{primary} = 6 μ H, for I_{LIM} = 2A only	5.8mm×5.8mm×3mm	TDK

Setting Output Voltage

The output voltage is set by selecting the resistive voltage divider ratio. If we use 1.2kΩ the low side resistor (R8) of the voltage divider, we can determine the high side resistor (R2, R5) by the equation:

$$R_2 = R_5 = \frac{1}{2} \frac{V_{out} - V_{FB}}{V_{FB}} R_8$$

Typical values are R2=R5=150kΩ and R8=1.2kΩ.

Output Diode Selection

The reverse voltage of the output diode is determined by:

$$V_D = V_{out} + NV_{in}$$

Quench Function

MP3352 has build-in quench function to accurately control exposure time and preserve power, thus to extend battery life.

When output capacitor is fully charged and IGBTIN (pin14) is set high, internal IGBT driver drives the gate of IGBT high and fires the flash strobe. Once the photo transistor gets the flash light, it starts to charge C and the voltage of C represents the total exposure. IGBT will be off when the voltage on C exceeds the control voltage on QREF (Pin3)

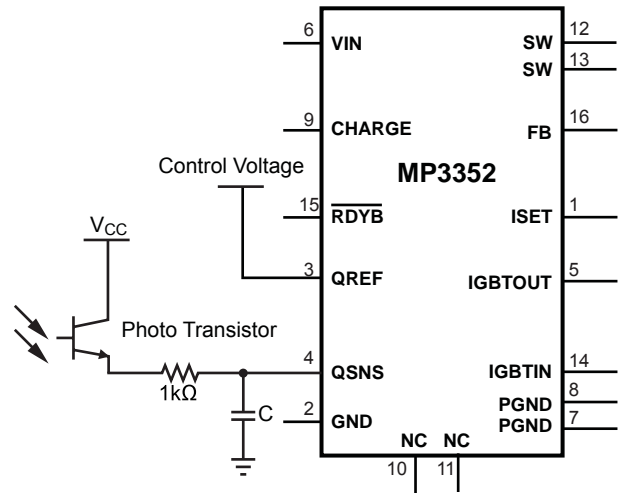

TYPICAL APPLICATION CIRCUIT

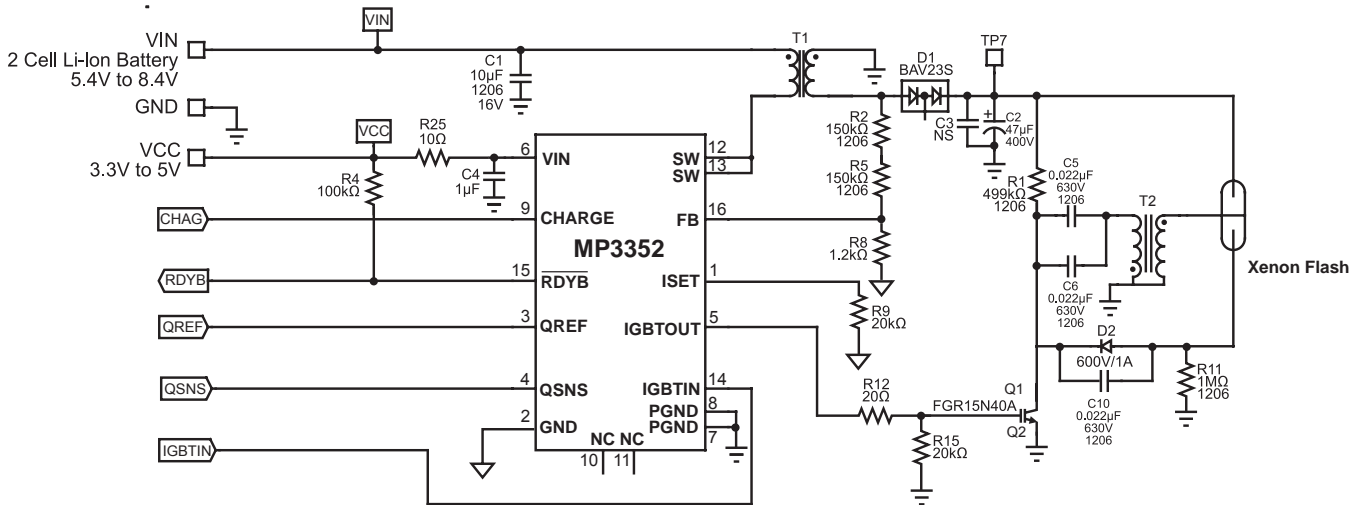
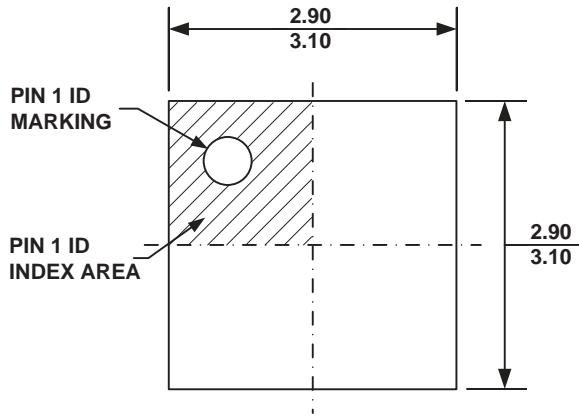

Figure 2—Application Circuit for 2 Cell Li-Ion Battery Photo Flash Charger

PACKAGE INFORMATION

QFN16-3(EXPOSED PAD)



TOP VIEW

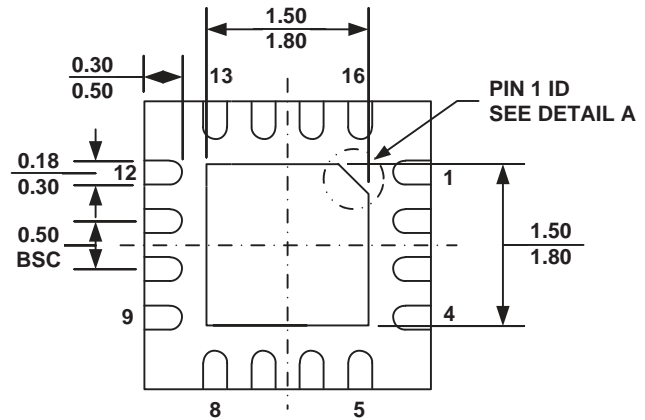

BOTTOM VIEW

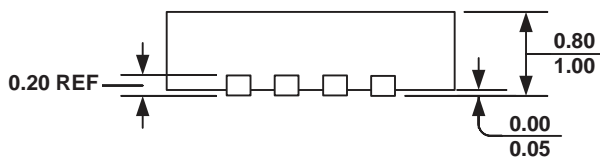

SIDE VIEW

PIN 1 ID OPTION A
0.30x45° TYP.

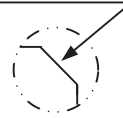

PIN 1 ID OPTION B
R0.20 TYP.

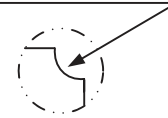

DETAIL A

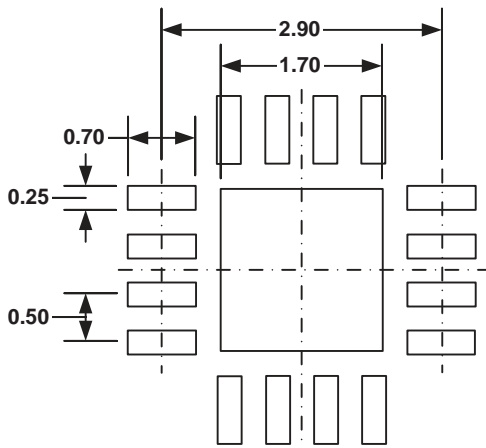

RECOMMENDED LAND PATTERN

NOTE:

- 1) ALL DIMENSIONS ARE IN MILLIMETERS.
- 2) EXPOSED PADDLE SIZE DOES NOT INCLUDE MOLD FLASH.
- 3) LEAD COPLANARITY SHALL BE 0.10 MILLIMETER MAX.
- 4) DRAWING CONFORMS TO JEDEC MO-220, VARIATION VEED-4.
- 5) DRAWING IS NOT TO SCALE.