



# AiP74HC/HCT365

## Hex Buffer/Line Driver; 3-state

### Product Specification

**Specification Revision History:**

Version	Date	Description
2012-06-A1	2012-06	New
2021-12-A2	2021-12	Modify ordering information
2022-01-A3	2022-01	Modify ambient temperature to $-40^{\circ}\text{C}\sim+105^{\circ}\text{C}$ and add electrical characteristics of $-40^{\circ}\text{C}\sim+105^{\circ}\text{C}$



## 1、 General Description

The AiP74HC/HCT365 is a hex buffer/line driver with 3-state outputs controlled by the output enable inputs ( $\overline{OEn}$ ). A HIGH on  $\overline{OEn}$  causes the outputs to assume a high impedance OFF-state. Inputs include clamp diodes. This enables the use of current limiting resistors to interface inputs to voltages in excess of  $V_{CC}$ .

### Features:

- Input levels:
  - For AiP74HC365: CMOS level
  - For AiP74HCT365: TTL level
- 3-state outputs
- Specified from -40°C to +105°C
- Packaging information: DIP16/SOP16/TSSOP16

### Ordering Information:

#### Tube packing specifications:

Part number	Packaging form	Marking code	Tube quantity	Boxed tube quantity	Boxed quantity	Notes
AiP74HC365DA16.TB	DIP16	74HC365	25 PCS/tube	40 tube/box	1000 PCS/box	Dimensions of plastic enclosure: 19.0mm×6.4mm Pin spacing: 2.54mm
AiP74HCT365DA16.TB	DIP16	74HCT365	25 PCS/tube	40 tube/box	1000 PCS/box	Dimensions of plastic enclosure: 19.0mm×6.4mm Pin spacing: 2.54mm
AiP74HC365SA16.TB	SOP16	74HC365	50 PCS/tube	100 tube/box	5000 PCS/box	Dimensions of plastic enclosure: 10.0mm×3.9mm Pin spacing: 1.27mm
AiP74HCT365SA16.TB	SOP16	74HCT365	50 PCS/tube	200 tube/box	10000 PCS/box	Dimensions of plastic enclosure: 10.0mm×3.9mm Pin spacing: 1.27mm
AiP74HC365TA16.TB	TSSOP16	74HC365	96 PCS/tube	200 tube/box	19200 PCS/box	Dimensions of plastic enclosure: 5.0mm×4.4mm Pin spacing: 0.65mm
AiP74HCT365TA16.TB	TSSOP16	74HCT365	96 PCS/tube	200 tube/box	19200 PCS/box	Dimensions of plastic enclosure: 5.0mm×4.4mm Pin spacing: 0.65mm

**Reel packing specifications:**

Part number	Packaging form	Marking code	Reel quantity	Boxed reel quantity	Notes
AiP74HC365SA16.TR	SOP16	74HC365	4000 PCS/reel	8000 PCS/box	Dimensions of plastic enclosure: 10.0mm×3.9mm Pin spacing:1.27mm
AiP74HCT365SA16.TR	SOP16	74HCT365	4000 PCS/reel	8000 PCS/box	Dimensions of plastic enclosure: 10.0mm×3.9mm Pin spacing:1.27mm
AiP74HC365TA16.TR	TSSOP16	74HC365	5000 PCS/reel	10000 PCS/box	Dimensions of plastic enclosure: 5.0mm×4.4mm Pin spacing:0.65mm
AiP74HCT365TA16.TR	TSSOP16	74HCT365	5000 PCS/reel	10000 PCS/box	Dimensions of plastic enclosure: 5.0mm×4.4mm Pin spacing:0.65mm

Note: If the physical information is inconsistent with the ordering information, please refer to the actual product.



## 2、Block Diagram And Pin Description

### 2.1、Block Diagram

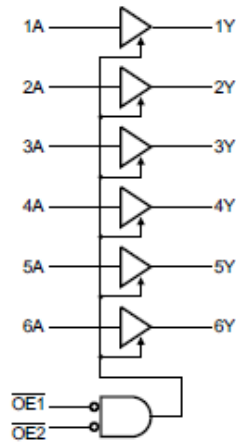

Figure 1. Logic symbol

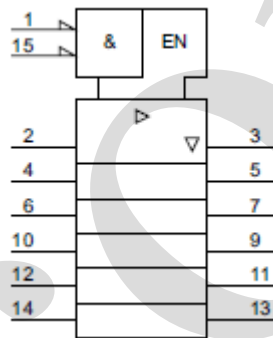

Figure 2. IEC logic symbol

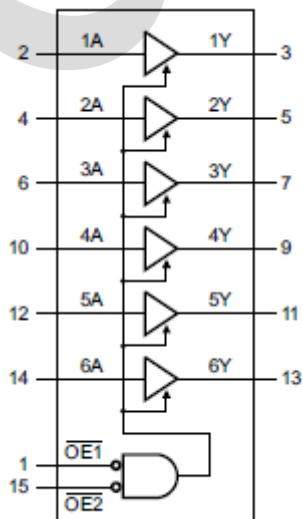

Figure 3. Functional diagram

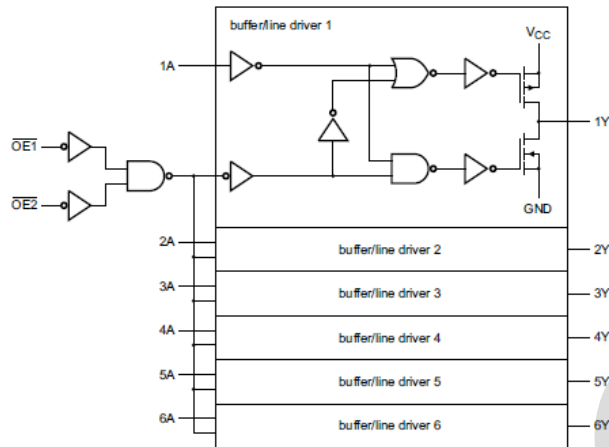
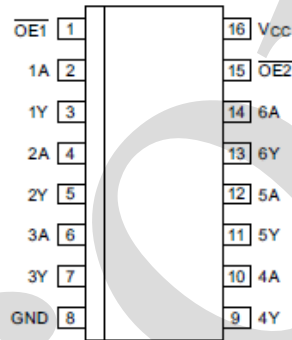

Figure 4. Logic diagram

## 2.2、 Pin Configurations



## 2.3、 Pin Description

Pin No.	Pin Name	Description
1	OE1	output enable input 1 (active LOW)
2	1A	data input 1
3	1Y	data output 1
4	2A	data input 2
5	2Y	data output 2
6	3A	data input 3
7	3Y	data output 3
8	GND	ground (0V)
9	4Y	data output 4
10	4A	data input 4
11	5Y	data output 5
12	5A	data input 5
13	6Y	data output 6
14	6A	data input 6
15	OE2	output enable input 2 (active LOW)
16	V <sub>CC</sub>	supply voltage



## 2.4、Function Table

Input			Output
OE1	OE2	nA	nY
L	L	L	L
L	L	H	H
X	H	X	Z
H	X	X	Z

Note: H=HIGH voltage level; L=LOW voltage level; X=don't care; Z=high-impedance OFF-state.

## 3、Electrical Parameter

### 3.1、Absolute Maximum Ratings

(Voltages are referenced to GND (ground=0V), unless otherwise specified.)

Parameter	Symbol	Conditions	Min.	Max.	Unit
supply voltage	$V_{CC}$	-	-0.5	+7.0	V
input clamping current	$I_{IK}$	$V_I < -0.5V$ or $V_I > V_{CC}+0.5V$	-	$\pm 20$	mA
output clamping current	$I_{OK}$	$V_O < -0.5V$ or $V_O > V_{CC}+0.5V$	-	$\pm 20$	mA
output current	$I_O$	$-0.5V < V_O < V_{CC}+0.5V$	-	$\pm 35$	mA
supply current	$I_{CC}$	-	-	70	mA
ground current	$I_{GND}$	-	-70	-	mA
storage temperature	$T_{stg}$	-	-65	+150	°C
total power dissipation	$P_{tot}$	-	-	500	mW
Soldering temperature	$T_L$	10s	DIP	245	°C
			SOP	250	

Note:

[1] For DIP16 packages: above 70°C the value of  $P_{tot}$  derates linearly with 12mW/K.

[2] For SOP16 packages: above 70°C the value of  $P_{tot}$  derates linearly with 8mW/K.

[3] For (T)SSOP16 packages: above 60°C the value of  $P_{tot}$  derates linearly with 5.5mW/K.



### 3.2、Recommended Operating Conditions

Parameter	Symbol	Conditions	Min.	Typ.	Max.	Unit
<b>AiP74HC365</b>						
supply voltage	$V_{CC}$	-	2.0	5.0	6.0	V
input voltage	$V_I$	-	0	-	$V_{CC}$	V
output voltage	$V_O$	-	0	-	$V_{CC}$	V
input transition rise and fall rate	$\Delta t/\Delta V$	$V_{CC}=2.0V$	-	-	625	ns/V
		$V_{CC}=4.5V$	-	1.67	139	ns/V
		$V_{CC}=6.0V$	-	-	83	ns/V
ambient temperature	$T_{amb}$	-	-40	-	+105	°C
<b>AiP74HCT365</b>						
supply voltage	$V_{CC}$	-	4.5	5.0	5.5	V
input voltage	$V_I$	-	0	-	$V_{CC}$	V
output voltage	$V_O$	-	0	-	$V_{CC}$	V
input transition rise and fall rate	$\Delta t/\Delta V$	$V_{CC}=4.5V$	-	1.67	139	ns/V
ambient temperature	$T_{amb}$	-	-40	-	+105	°C

### 3.3、Electrical Characteristics

#### 3.3.1、DC Characteristics 1

( $T_{amb}=25^{\circ}C$ , voltages are referenced to GND (ground=0V), unless otherwise specified.)

Parameter	Symbol	Conditions	Min.	Typ.	Max.	Unit	
<b>AiP74HC365</b>							
HIGH-level input voltage	$V_{IH}$	$V_{CC}=2.0V$	1.5	1.2	-	V	
		$V_{CC}=4.5V$	3.15	2.4	-	V	
		$V_{CC}=6.0V$	4.2	3.2	-	V	
LOW-level input voltage	$V_{IL}$	$V_{CC}=2.0V$	-	0.8	0.5	V	
		$V_{CC}=4.5V$	-	2.1	1.35	V	
		$V_{CC}=6.0V$	-	2.8	1.8	V	
HIGH-level output voltage	$V_{OH}$	$V_I = V_{IH} \text{ or } V_{IL}$	$I_O=-20\mu A; V_{CC}=2.0V$	1.9	2.0	-	V
			$I_O=-20\mu A; V_{CC}=4.5V$	4.4	4.5	-	V
			$I_O=-20\mu A; V_{CC}=6.0V$	5.9	6.0	-	V
			$I_O=-6.0mA; V_{CC}=4.5V$	3.98	4.32	-	V
			$I_O=-7.8mA; V_{CC}=6.0V$	5.48	5.81	-	V
LOW-level output voltage	$V_{OL}$	$V_I = V_{IH} \text{ or } V_{IL}$	$I_O=20\mu A; V_{CC}=2.0V$	-	0	0.1	V
			$I_O=20\mu A; V_{CC}=4.5V$	-	0	0.1	V
			$I_O=20\mu A; V_{CC}=6.0V$	-	0	0.1	V
			$I_O=6.0mA; V_{CC}=4.5V$	-	0.15	0.26	V
			$I_O=7.8mA; V_{CC}=6.0V$	-	0.16	0.26	V
input leakage current	$I_I$	$V_I=V_{CC} \text{ or } GND;$ $V_{CC}=6.0V$	-	-	$\pm 0.1$	$\mu A$	
OFF-state output current	$I_{OZ}$	$V_I=V_{IH} \text{ or } V_{IL}; V_{CC}=6.0V;$ $V_O=V_{CC} \text{ or } GND$	-	-	$\pm 0.5$	$\mu A$	
supply current	$I_{CC}$	$V_I=V_{CC} \text{ or } GND; I_O=0A; V_{CC}=6.0V$	-	-	8.0	$\mu A$	



input capacitance	$C_I$	-	-	3.5	-	pF	
<b>AiP74HCT365</b>							
HIGH-level input voltage	$V_{IH}$	$V_{CC}=4.5V$ to $5.5V$	2.0	1.6	-	V	
LOW-level input voltage	$V_{IL}$	$V_{CC}=4.5V$ to $5.5V$	-	1.2	0.8	V	
HIGH-level output voltage	$V_{OH}$	$V_I = V_{IH}$ or $V_{IL};$ $V_{CC}=4.5V$	$I_O=-20\mu A$	4.4	4.5	-	V
			$I_O=-6.0mA$	3.98	4.32	-	V
LOW-level output voltage	$V_{OL}$	$V_I = V_{IH}$ or $V_{IL};$ $V_{CC}=4.5V$	$I_O=20\mu A$	-	0	0.1	V
			$I_O=6.0mA$	-	0.16	0.26	V
input leakage current	$I_I$	$V_I=V_{CC}$ or GND; $V_{CC}=5.5V$	-	-	$\pm 0.1$	$\mu A$	
OFF-state output current	$I_{OZ}$	$V_I=V_{IH}$ or $V_{IL}; V_{CC}=5.5V;$ $V_O=V_{CC}$ or GND	-	-	$\pm 0.5$	$\mu A$	
supply current	$I_{CC}$	$V_I=V_{CC}$ or GND; $I_O=0A; V_{CC}=5.5V$	-	-	8.0	$\mu A$	
additional supply current	$\Delta I_{CC}$	$V_I=V_{CC}-2.1V;$ other inputs at $V_{CC}$ or GND; $I_O=0A$	pins nA	-	100	360	$\mu A$
			pin $\overline{OE1}$	-	100	360	$\mu A$
			pin $\overline{OE2}$	-	90	324	$\mu A$
input capacitance	$C_I$	-	-	3.5	-	pF	

### 3.3.2、DC Characteristics 2

( $T_{amb}=-40^{\circ}C$  to  $+85^{\circ}C$ , voltages are referenced to GND (ground=0V), unless otherwise specified.)

Parameter	Symbol	Conditions	Min.	Typ.	Max.	Unit	
<b>AiP74HC365</b>							
HIGH-level input voltage	$V_{IH}$	$V_{CC}=2.0V$	1.5	-	-	V	
		$V_{CC}=4.5V$	3.15	-	-	V	
		$V_{CC}=6.0V$	4.2	-	-	V	
LOW-level input voltage	$V_{IL}$	$V_{CC}=2.0V$	-	-	0.5	V	
		$V_{CC}=4.5V$	-	-	1.35	V	
		$V_{CC}=6.0V$	-	-	1.8	V	
HIGH-level output voltage	$V_{OH}$	$V_I = V_{IH}$ or $V_{IL}$	$I_O=-20\mu A; V_{CC}=2.0V$	1.9	-	-	V
			$I_O=-20\mu A; V_{CC}=4.5V$	4.4	-	-	V
			$I_O=-20\mu A; V_{CC}=6.0V$	5.9	-	-	V
			$I_O=-6.0mA; V_{CC}=4.5V$	3.84	-	-	V
			$I_O=-7.8mA; V_{CC}=6.0V$	5.34	-	-	V
LOW-level output voltage	$V_{OL}$	$V_I = V_{IH}$ or $V_{IL}$	$I_O=20\mu A; V_{CC}=2.0V$	-	-	0.1	V
			$I_O=20\mu A; V_{CC}=4.5V$	-	-	0.1	V
			$I_O=20\mu A; V_{CC}=6.0V$	-	-	0.1	V
			$I_O=6.0mA; V_{CC}=4.5V$	-	-	0.33	V
			$I_O=7.8mA; V_{CC}=6.0V$	-	-	0.33	V
input leakage current	$I_I$	$V_I=V_{CC}$ or GND; $V_{CC}=6.0V$	-	-	$\pm 1.0$	$\mu A$	
OFF-state output current	$I_{OZ}$	$V_I=V_{IH}$ or $V_{IL}; V_{CC}=6.0V;$ $V_O=V_{CC}$ or GND	-	-	$\pm 5.0$	$\mu A$	
supply current	$I_{CC}$	$V_I=V_{CC}$ or GND; $I_O=0A; V_{CC}=6.0V$	-	-	80	$\mu A$	





AiP74HCT365							
HIGH-level input voltage	$V_{IH}$	$V_{CC}=4.5V$ to $5.5V$	2.0	-	-	V	
LOW-level input voltage	$V_{IL}$	$V_{CC}=4.5V$ to $5.5V$	-	-	0.8	V	
HIGH-level output voltage	$V_{OH}$	$V_I = V_{IH}$ or $V_{IL}$ ; $V_{CC}=4.5V$	$I_O=-20\mu A$	4.4	-	-	V
			$I_O=-6.0mA$	3.84	-	-	V
LOW-level output voltage	$V_{OL}$	$V_I = V_{IH}$ or $V_{IL}$ ; $V_{CC}=4.5V$	$I_O=20\mu A$	-	-	0.1	V
			$I_O=6.0mA$	-	-	0.33	V
input leakage current	$I_I$	$V_I=V_{CC}$ or GND; $V_{CC}=5.5V$	-	-	$\pm 1.0$	$\mu A$	
OFF-state output current	$I_{OZ}$	$V_I=V_{IH}$ or $V_{IL}$ ; $V_{CC}=5.5V$ ; $V_O=V_{CC}$ or GND	-	-	$\pm 5.0$	$\mu A$	
supply current	$I_{CC}$	$V_I=V_{CC}$ or GND; $I_O=0A$ ; $V_{CC}=5.5V$	-	-	80	$\mu A$	
additional supply current	$\Delta I_{CC}$	$V_I=V_{CC}-2.1V$ ; other inputs at $V_{CC}$ or GND; $I_O=0A$	pins nA	-	-	450	$\mu A$
			pin OE1	-	-	450	$\mu A$
			pin OE2	-	-	405	$\mu A$

### 3.3.3、DC Characteristics 3

( $T_{amb}=-40^{\circ}C$  to  $+105^{\circ}C$ , voltages are referenced to GND (ground=0V), unless otherwise specified.)

Parameter	Symbol	Conditions	Min.	Typ.	Max.	Unit	
<b>AiP74HC365</b>							
HIGH-level input voltage	$V_{IH}$	$V_{CC}=2.0V$	1.5	-	-	V	
		$V_{CC}=4.5V$	3.15	-	-	V	
		$V_{CC}=6.0V$	4.2	-	-	V	
LOW-level input voltage	$V_{IL}$	$V_{CC}=2.0V$	-	-	0.5	V	
		$V_{CC}=4.5V$	-	-	1.35	V	
		$V_{CC}=6.0V$	-	-	1.8	V	
HIGH-level output voltage	$V_{OH}$	$V_I = V_{IH}$ or $V_{IL}$	$I_O=-20\mu A$ ; $V_{CC}=2.0V$	1.9	-	-	V
			$I_O=-20\mu A$ ; $V_{CC}=4.5V$	4.4	-	-	V
			$I_O=-20\mu A$ ; $V_{CC}=6.0V$	5.9	-	-	V
			$I_O=-6.0mA$ ; $V_{CC}=4.5V$	3.7	-	-	V
			$I_O=-7.8mA$ ; $V_{CC}=6.0V$	5.2	-	-	V
LOW-level output voltage	$V_{OL}$	$V_I = V_{IH}$ or $V_{IL}$	$I_O=20\mu A$ ; $V_{CC}=2.0V$	-	-	0.1	V
			$I_O=20\mu A$ ; $V_{CC}=4.5V$	-	-	0.1	V
			$I_O=20\mu A$ ; $V_{CC}=6.0V$	-	-	0.1	V
			$I_O=6.0mA$ ; $V_{CC}=4.5V$	-	-	0.4	V
			$I_O=7.8mA$ ; $V_{CC}=6.0V$	-	-	0.4	V
input leakage current	$I_I$	$V_I=V_{CC}$ or GND; $V_{CC}=6.0V$	-	-	$\pm 1.0$	$\mu A$	
OFF-state output current	$I_{OZ}$	$V_I=V_{IH}$ or $V_{IL}$ ; $V_{CC}=6.0V$ ; $V_O=V_{CC}$ or GND	-	-	$\pm 10$	$\mu A$	
supply current	$I_{CC}$	$V_I=V_{CC}$ or GND; $I_O=0A$ ; $V_{CC}=6.0V$	-	-	160	$\mu A$	
<b>AiP74HCT365</b>							
HIGH-level input voltage	$V_{IH}$	$V_{CC}=4.5V$ to $5.5V$	2.0	-	-	V	
LOW-level	$V_{IL}$	$V_{CC}=4.5V$ to $5.5V$	-	-	0.8	V	



input voltage							
HIGH-level output voltage	$V_{OH}$	$V_I = V_{IH}$ or $V_{IL}$ ; $V_{CC}=4.5V$	$I_O=-20\mu A$	4.4	-	-	V
			$I_O=-6.0mA$	3.7	-	-	V
LOW-level output voltage	$V_{OL}$	$V_I = V_{IH}$ or $V_{IL}$ ; $V_{CC}=4.5V$	$I_O=20\mu A$	-	-	0.1	V
			$I_O=6.0mA$	-	-	0.4	V
input leakage current	$I_I$	$V_I=V_{CC}$ or GND; $V_{CC}=5.5V$		-	-	$\pm 1.0$	$\mu A$
OFF-state output current	$I_{OZ}$	$V_I=V_{IH}$ or $V_{IL}$ ; $V_{CC}=5.5V$ ; $V_O=V_{CC}$ or GND		-	-	$\pm 10$	$\mu A$
supply current	$I_{CC}$	$V_I=V_{CC}$ or GND; $I_O=0A$ ; $V_{CC}=5.5V$		-	-	160	$\mu A$
additional supply current	$\Delta I_{CC}$	$V_I=V_{CC}-2.1V$ ; other inputs at $V_{CC}$ or GND; $I_O=0A$	pins nA	-	-	490	$\mu A$
			pin $\overline{OE}1$	-	-	490	$\mu A$
			pin $\overline{OE}2$	-	-	441	$\mu A$

### 3.3.4、AC Characteristics 1

( $T_{amb}=25^\circ C$ , GND =0V,  $C_L=50pF$ , unless otherwise specified.)

Parameter	Symbol	Conditions	Min.	Typ.	Max.	Unit	
<b>AiP74HC365</b>							
nA to nY propagation delay	$t_{pd}$	see Figure 6	$V_{CC}=2.0V$	-	30	95	ns
			$V_{CC}=4.5V$	-	11	19	ns
			$V_{CC}=5.0V$ ; $C_L=15pF$	-	9	-	ns
			$V_{CC}=6.0V$	-	9	16	ns
$\overline{OEn}$ to nY enable time	$t_{en}$	see Figure 7	$V_{CC}=2.0V$	-	47	150	ns
			$V_{CC}=4.5V$	-	17	30	ns
			$V_{CC}=6.0V$	-	14	26	ns
$\overline{OEn}$ to nY disable time	$t_{dis}$	see Figure 7	$V_{CC}=2.0V$	-	61	150	ns
			$V_{CC}=4.5V$	-	22	30	ns
			$V_{CC}=6.0V$	-	18	26	ns
transition time	$t_t$	see Figure 6	$V_{CC}=2.0V$	-	14	60	ns
			$V_{CC}=4.5V$	-	5	12	ns
			$V_{CC}=6.0V$	-	4	10	ns
power dissipation capacitance	$C_{PD}$	per buffer; $V_I=GND$ to $V_{CC}$	-	40	-	pF	
<b>AiP74HCT365</b>							
nA to nY propagation delay	$t_{pd}$	see Figure 6	$V_{CC}=4.5V$	-	14	25	ns
			$V_{CC}=5.0V$ ; $C_L=15pF$	-	11	-	ns
$\overline{OEn}$ to nY enable time	$t_{en}$	$V_{CC}=4.5V$ ; see Figure 7	-	18	35	ns	
$\overline{OEn}$ to nY disable time	$t_{dis}$	$V_{CC}=4.5V$ ; see Figure 7	-	23	35	ns	
transition time	$t_t$	$V_{CC}=4.5V$ ; see Figure 6	-	5	12	ns	
power dissipation capacitance	$C_{PD}$	per buffer; $V_I=GND$ to $V_{CC}-1.5V$	-	40	-	pF	

Note:



- [1]  $t_{pd}$  is the same as  $t_{PLH}$  and  $t_{PHL}$ .
- [2]  $t_{en}$  is the same as  $t_{PZL}$  and  $t_{PZH}$ .
- [3]  $t_{dis}$  is the same as  $t_{PLZ}$  and  $t_{PHZ}$ .
- [4]  $t_t$  is the same as  $t_{THL}$  and  $t_{TLH}$ .
- [5]  $C_{PD}$  is used to determine the dynamic power dissipation ( $P_D$  in uW).

$$P_D = C_{PD} \times V_{CC}^2 \times f_i \times N + \sum (C_L \times V_{CC}^2 \times f_o) \text{ where:}$$

$f_i$ =input frequency in MHz;

$f_o$ =output frequency in MHz;

$C_L$ =output load capacitance in pF;

$V_{CC}$ =supply voltage in V;

$N$ =number of inputs switching;

$\sum (C_L \times V_{CC}^2 \times f_o)$ =sum of outputs.

### 3.3.5、 AC Characteristics 2

( $T_{amb} = -40^\circ\text{C}$  to  $+85^\circ\text{C}$ ,  $GND = 0V$ ,  $C_L = 50pF$ , unless otherwise specified.)

Parameter	Symbol	Conditions	Min.	Typ.	Max.	Unit	
<b>AiP74HC365</b>							
nA to nY propagation delay	$t_{pd}$	see Figure 6	$V_{CC} = 2.0V$	-	-	120	ns
			$V_{CC} = 4.5V$	-	-	24	ns
			$V_{CC} = 6.0V$	-	-	20	ns
$\overline{O}En$ to nY enable time	$t_{en}$	see Figure 7	$V_{CC} = 2.0V$	-	-	190	ns
			$V_{CC} = 4.5V$	-	-	38	ns
			$V_{CC} = 6.0V$	-	-	33	ns
$\overline{O}En$ to nY disable time	$t_{dis}$	see Figure 7	$V_{CC} = 2.0V$	-	-	190	ns
			$V_{CC} = 4.5V$	-	-	38	ns
			$V_{CC} = 6.0V$	-	-	33	ns
transition time	$t_t$	see Figure 6	$V_{CC} = 2.0V$	-	-	75	ns
			$V_{CC} = 4.5V$	-	-	15	ns
			$V_{CC} = 6.0V$	-	-	13	ns
<b>AiP74HCT365</b>							
nA to nY propagation delay	$t_{pd}$	see Figure 6	$V_{CC} = 4.5V$	-	-	31	ns
$\overline{O}En$ to nY enable time	$t_{en}$	$V_{CC} = 4.5V$ ; see Figure 7		-	-	44	ns
$\overline{O}En$ to nY disable time	$t_{dis}$	$V_{CC} = 4.5V$ ; see Figure 7		-	-	44	ns
transition time	$t_t$	$V_{CC} = 4.5V$ ; see Figure 6		-	-	15	ns

Note:

- [1]  $t_{pd}$  is the same as  $t_{PLH}$  and  $t_{PHL}$ .
- [2]  $t_{en}$  is the same as  $t_{PZL}$  and  $t_{PZH}$ .
- [3]  $t_{dis}$  is the same as  $t_{PLZ}$  and  $t_{PHZ}$ .
- [4]  $t_t$  is the same as  $t_{THL}$  and  $t_{TLH}$ .



### 3.3.6. AC Characteristics 3

( $T_{amb} = -40^{\circ}\text{C}$  to  $+105^{\circ}\text{C}$ ,  $GND = 0\text{V}$ ,  $C_L = 50\text{pF}$ , unless otherwise specified.)

Parameter	Symbol	Conditions	Min.	Typ.	Max.	Unit	
<b>AiP74HC365</b>							
nA to nY propagation delay	$t_{pd}$	see Figure 6	$V_{CC} = 2.0\text{V}$	-	-	145	ns
			$V_{CC} = 4.5\text{V}$	-	-	29	ns
			$V_{CC} = 6.0\text{V}$	-	-	25	ns
$\overline{\text{OEn}}$ to nY enable time	$t_{en}$	see Figure 7	$V_{CC} = 2.0\text{V}$	-	-	225	ns
			$V_{CC} = 4.5\text{V}$	-	-	45	ns
			$V_{CC} = 6.0\text{V}$	-	-	38	ns
$\overline{\text{OEn}}$ to nY disable time	$t_{dis}$	see Figure 7	$V_{CC} = 2.0\text{V}$	-	-	225	ns
			$V_{CC} = 4.5\text{V}$	-	-	45	ns
			$V_{CC} = 6.0\text{V}$	-	-	38	ns
transition time	$t_t$	see Figure 6	$V_{CC} = 2.0\text{V}$	-	-	90	ns
			$V_{CC} = 4.5\text{V}$	-	-	18	ns
			$V_{CC} = 6.0\text{V}$	-	-	15	ns
<b>AiP74HCT365</b>							
nA to nY propagation delay	$t_{pd}$	see Figure 6	$V_{CC} = 4.5\text{V}$	-	-	38	ns
$\overline{\text{OEn}}$ to nY enable time	$t_{en}$	$V_{CC} = 4.5\text{V}$ ; see Figure 7		-	-	53	ns
$\overline{\text{OEn}}$ to nY disable time	$t_{dis}$	$V_{CC} = 4.5\text{V}$ ; see Figure 7		-	-	53	ns
transition time	$t_t$	$V_{CC} = 4.5\text{V}$ ; see Figure 6		-	-	18	ns

Note:

- [1]  $t_{pd}$  is the same as  $t_{PLH}$  and  $t_{PHL}$ .
- [2]  $t_{en}$  is the same as  $t_{PZL}$  and  $t_{PZH}$ .
- [3]  $t_{dis}$  is the same as  $t_{PLZ}$  and  $t_{PHZ}$ .
- [4]  $t_t$  is the same as  $t_{THL}$  and  $t_{TLH}$ .



## 4、 Testing Circuit

### 4.1、 AC Testing Circuit

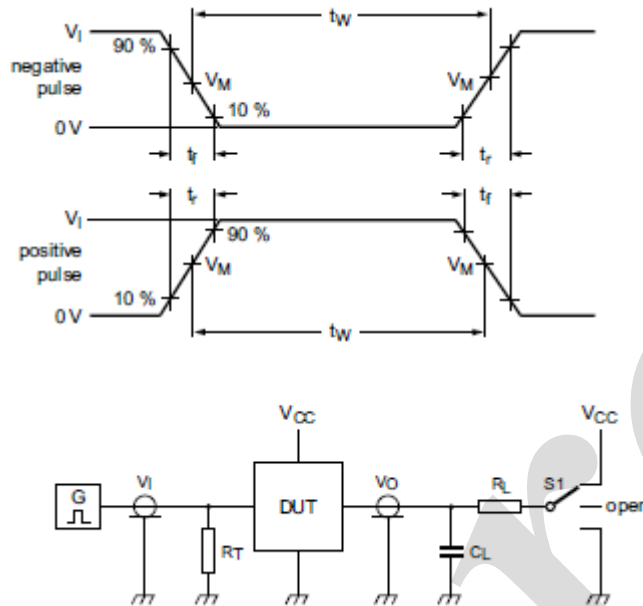

Figure 5. Test circuit for measuring switching times

Definitions for test circuit:

$R_L$ =Load resistance.

$C_L$ =Load capacitance including jig and probe capacitance.

$R_T$ =Termination resistance should be equal to the output impedance  $Z_o$  of the pulse generator.

S1=Test selection switch.

### 4.2、 AC Testing Waveforms

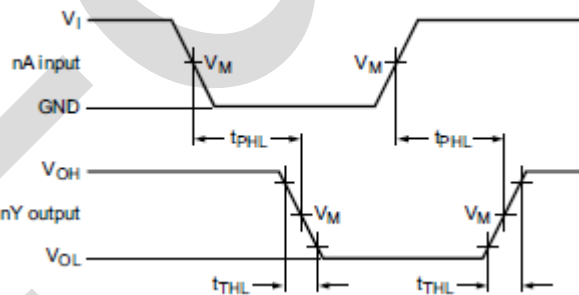

Figure 6. Input (nA) to output (nY) propagation delays and output transition times

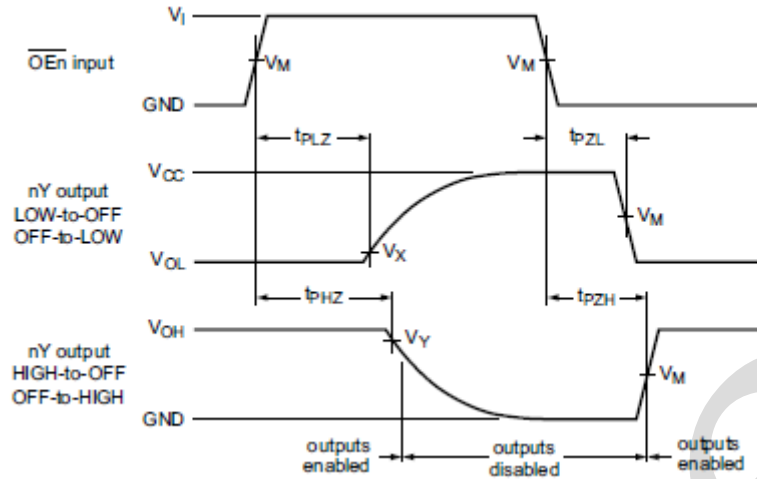

Figure 7. 3-state enable and disable times

### 4.3、 Measurement Points

Type	Input		Output	
	$V_M$	$V_M$	$V_X$	$V_Y$
AiP74HC365	$0.5 \times V_{CC}$	$0.5 \times V_{CC}$	$0.1 \times V_{CC}$	$0.9 \times V_{CC}$
AiP74HCT365	1.3V	1.3V	$0.1 \times V_{CC}$	$0.9 \times V_{CC}$

### 4.4、 Test Data

Type	Input		Load		S1 position		
	$V_I$	$t_r, t_f$	$C_L$	$R_L$	$t_{PHL}, t_{PLH}$	$t_{PZH}, t_{PHZ}$	$t_{PZL}, t_{PLZ}$
AiP74HC365	$V_{CC}$	6ns	15pF, 50pF	1k $\Omega$	open	GND	$V_{CC}$
AiP74HCT365	3V	6ns	15pF, 50pF	1k $\Omega$	open	GND	$V_{CC}$



## 5、Package Information

### 5.1、DIP16

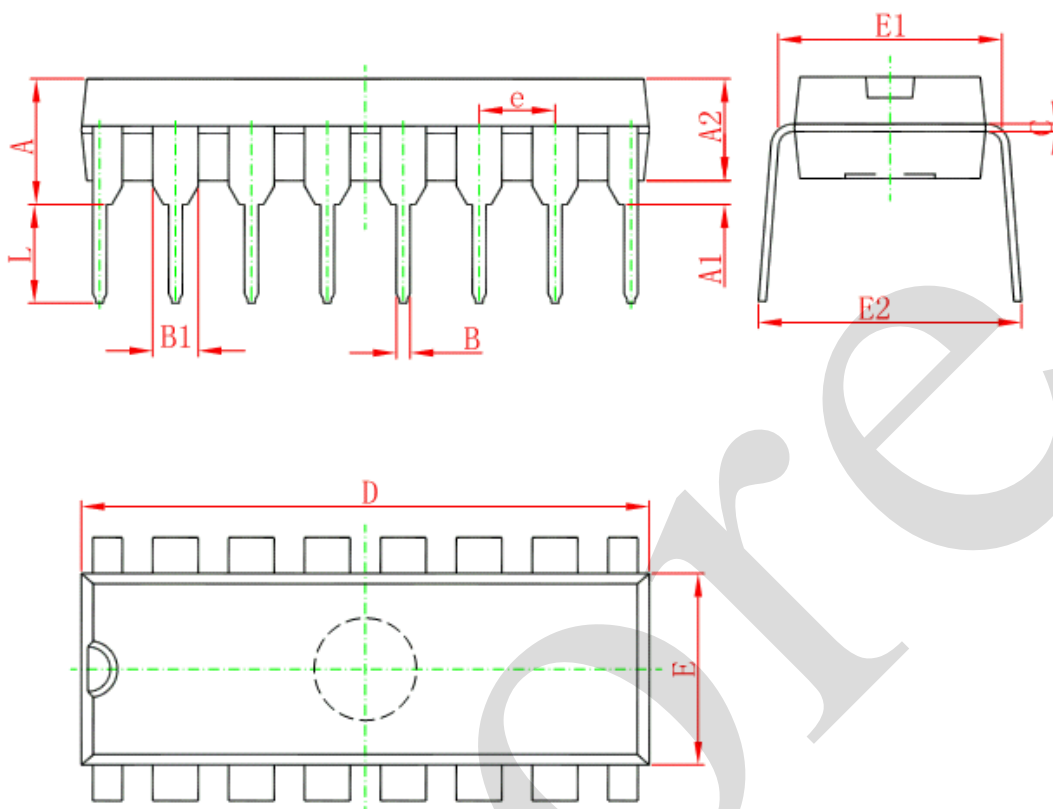

Symbol	Dimensions In Millimeters		Dimensions In Inches	
	Min	Max	Min	Max
A	3.710	4.310	0.146	0.170
A1	0.510		0.020	
A2	3.200	3.600	0.126	0.142
B	0.380	0.570	0.015	0.022
B1	1.524 (BSC)		0.060 (BSC)	
C	0.204	0.360	0.008	0.014
D	18.800	19.200	0.740	0.756
E	6.200	6.600	0.244	0.260
E1	7.320	7.920	0.288	0.312
e	2.540 (BSC)		0.100 (BSC)	
L	3.000	3.600	0.118	0.142
E2	8.400	9.000	0.331	0.354



## 5.2、SOP16

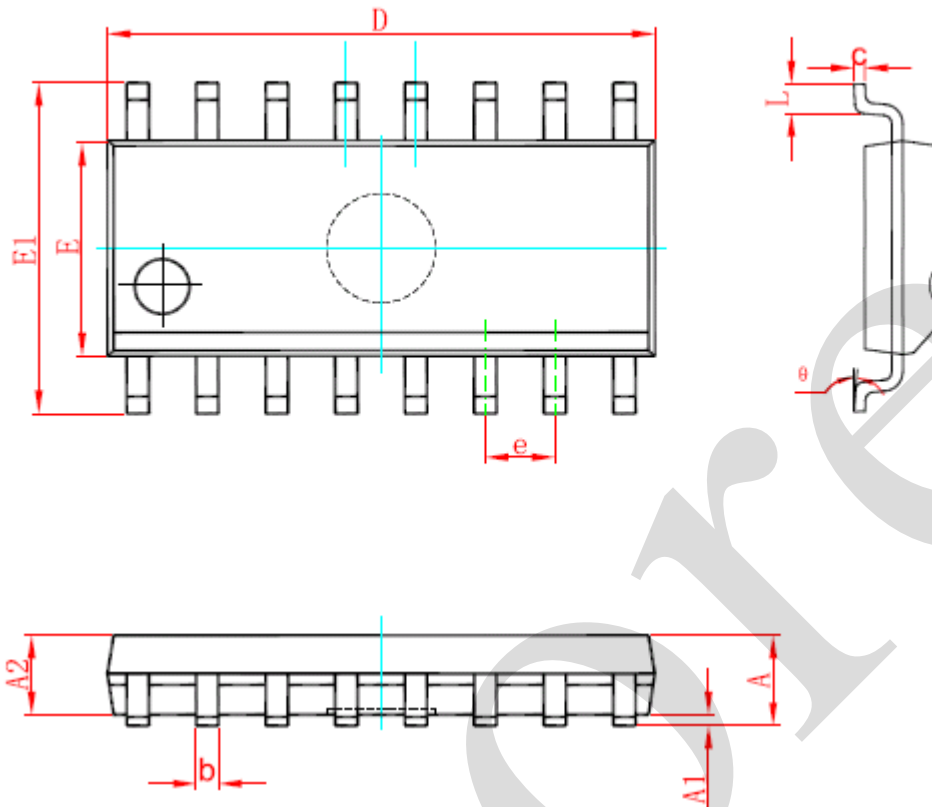

Symbol	Dimensions In Millimeters		Dimensions In Inches	
	Min	Max	Min	Max
A	1.350	1.750	0.053	0.069
A1	0.100	0.250	0.004	0.010
A2	1.350	1.550	0.053	0.061
b	0.330	0.510	0.013	0.020
c	0.170	0.250	0.007	0.010
D	9.800	10.200	0.386	0.402
E	3.800	4.000	0.150	0.157
E1	5.800	6.200	0.228	0.244
e	1.270 (BSC)		0.050 (BSC)	
L	0.400	1.270	0.016	0.050
θ	0°	8°	0°	8°





5.3、TSSOP16

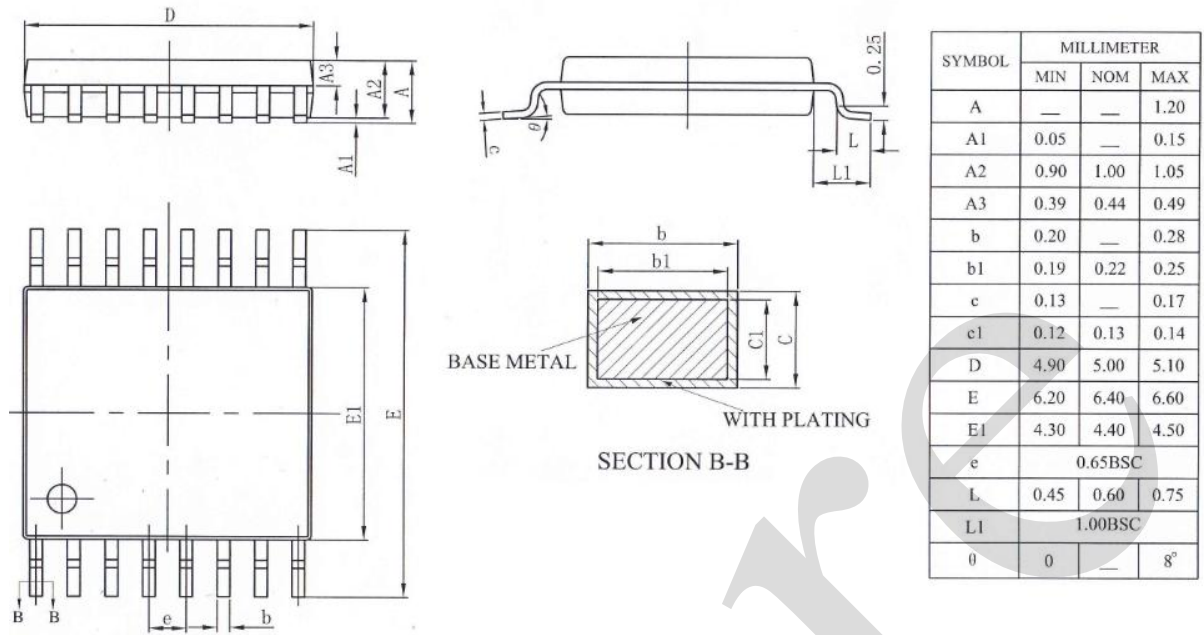



## 6、 Statements And Notes

### 6.1、 The name and content of Hazardous substances or Elements in the product

Part name	Hazardous substances or Elements									
	Lead and lead compounds	Mercury and mercury compounds	Cadmium and cadmium compounds	Hexavalent chromium compounds	Polybrominated biphenyls	Polybrominated biphenyl ethers	Dibutyl phthalate	Butylbenzyl phthalate	Di-2-ethylhexyl phthalate	Diisobutyl phthalate
Lead frame	○	○	○	○	○	○	○	○	○	○
Plastic resin	○	○	○	○	○	○	○	○	○	○
Chip	○	○	○	○	○	○	○	○	○	○
The lead	○	○	○	○	○	○	○	○	○	○
Plastic sheet installed	○	○	○	○	○	○	○	○	○	○
explanation	○: Indicates that the content of hazardous substances or elements in the detection limit of the following the SJ/T11363-2006 standard. ×: Indicates that the content of hazardous substances or elements exceeding the SJ/T11363-2006 Standard limit requirements.									

### 6.2、 Notion

Recommended carefully reading this information before the use of this product;

The information in this document are subject to change without notice;

This information is using to the reference only, the company is not responsible for any loss;

The company is not responsible for the any infringement of the third party patents or other rights of the responsibility.