

QN FEMALE - QN FEMALE ADAPTER

R164.705.000

Series : QN

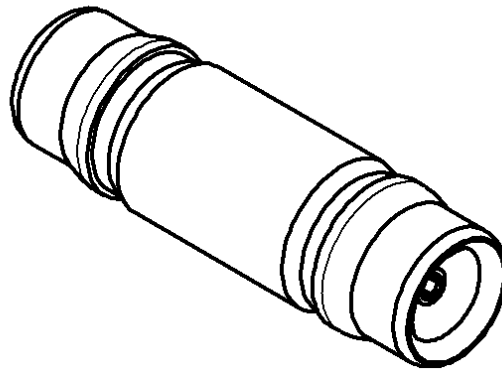
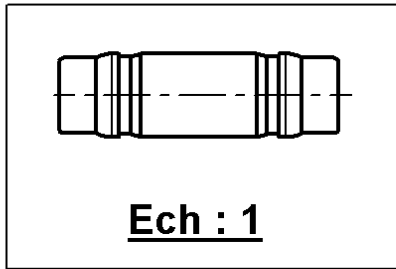
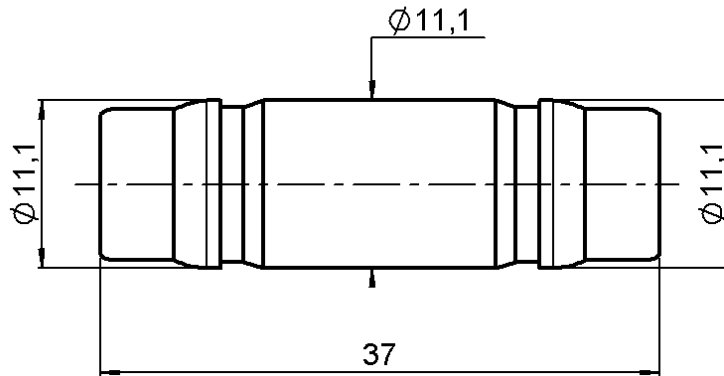

All dimensions are in mm.

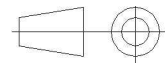

COMPONENTS	MATERIALS	PLATINGS (μm)
BODY	BRASS	BBR 0.5 OVER SILVER 3
CENTER CONTACT	BERYLLIUM COPPER	SILVER 5 PASSIVATED OVER COPPER 0.5
OUTER CONTACT		
INSULATOR	PTFE	
GASKET		
OTHERS PARTS		
-	-	-
-	-	-

Issue : 0420 B

In the effort to improve our products, we reserve the right to make changes judged to be necessary.



QN FEMALE - QN FEMALE ADAPTER

R164.705.000

Series : QN

PACKAGING

SPECIFICATION

Standard	Unit	Other
50	'W' option	Contact us

ELECTRICAL CHARACTERISTICS

ENVIRONMENTAL

Impedance		50 Ω
Frequency		0-6* GHz
VSWR	1.05 +	0.025 x F(GHz) Maxi
Insertion loss		0.048 √F(GHz) dB Maxi
RF leakage	- (**90 - F(GHz)) dB Maxi
Voltage rating		1400 Veff Maxi
Dielectric withstanding voltage		2500 Veff mini
Insulation resistance		5000 MΩ mini

Operating temperature	-55/+125 ° C
Hermetic seal	Atm.cm3/s
Panel leakage	

OTHERS CHARACTERISTICS

Assembly instruction

Others :

- * usable 0-11GHz
- **RF Leakage: -80dB min 3<F<6GHz
- ***PIM3: -112 dBm (2 x 20W at 1.8GHz)

MECHANICAL CHARACTERISTICS

Center contact retention		
Axial force – Mating end	27	N mini
Axial force – Opposite end	27	N mini
Torque	NA	N.cm mini
Recommended torque		
Mating	NA	N.cm
Panel nut	NA	N.cm
Mating life	100	Cycles mini
Weight	18.300	g

Issue : 0420 B

In the effort to improve our products, we reserve the right to make changes judged to be necessary.

