

# DG116/118/123/125

## 4 and 5-Channel Driver-MOS-FET

### Switch Combinations

### (Military Series -55°C to +125°C)

#### FEATURES

- Available With and Without Programmable Constant Current pull-up
- Zener Protection on All Gates
- P-Channel Enhancement-Type MOS-FET, Switches
- Each Switch Summed to One Common Point

#### GENERAL DESCRIPTION

This series includes devices with four and five channel switching capability. Each channel is composed of a driver and a MOS-FET switch. Two driver versions are supplied for inverting and noninverting applications. A MOS-FET, used as a current source provides an active pull-up for faster switching.

An external biasing connection is brought out for biasing the current source for optimization of speed and power.

3

#### SCHEMATIC AND LOGIC DIAGRAMS (Outline Dwgs DD, FD-2, JD)

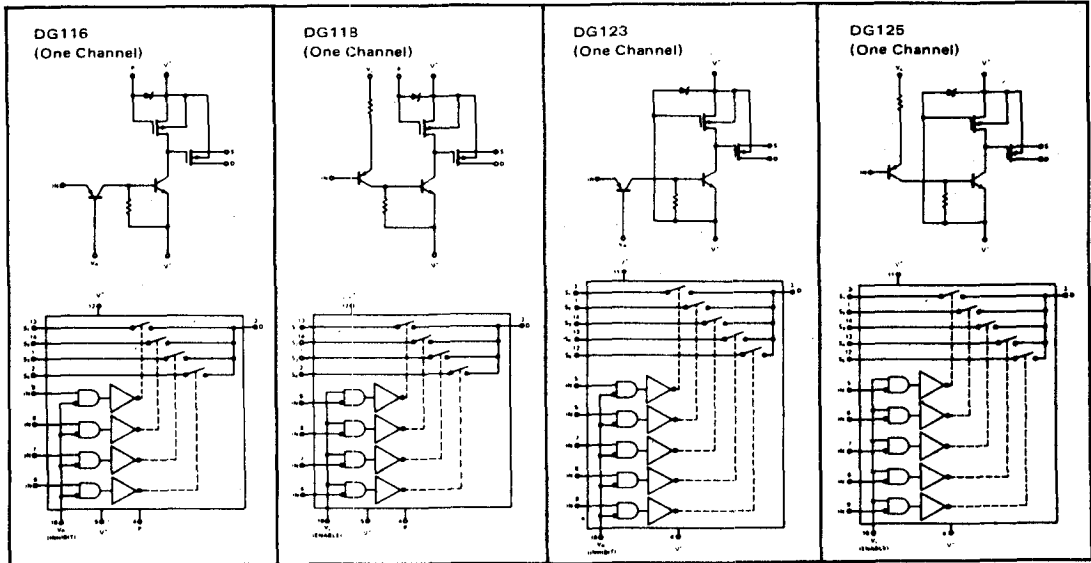

#### ORDERING INFORMATION

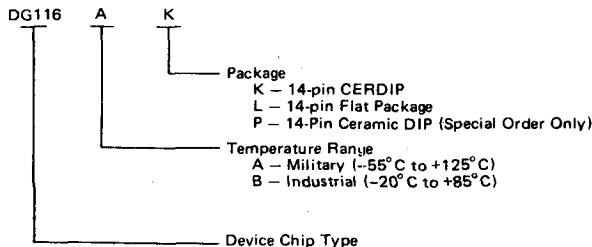

#### TRUTH TABLE

DG116, DG123		DG118, DG125		Switch
V <sub>IN</sub>	V <sub>R</sub>	V <sub>IN</sub>	V <sub>L</sub>	Cond.
L	L	L	L	OFF
H	L	L	H	ON
L	H	H	L	OFF
H	H	H	H	OFF

L = 0V, H = +V

**ABSOLUTE MAXIMUM RATINGS**

Collector to Emitter ( $V^+ - V^-$ )	33V	Input to Emitter ( $V_{IN} - V^-$ )	33V
Collector to Pull-up ( $V^+ - V_P$ )	33V	Current (any terminal)	30mA
Drain to Emitter ( $V_D - V^-$ )	32V	Storage Temperature	-65°C to +150°C
Source to Emitter ( $V_S - V^-$ )	32V	Operating Temperature	-55°C to +125°C
Drain to Source ( $V_D - V_S$ )	28V	Dissipation (Note)	750mW
Source to Drain ( $V_S - V_D$ )	28V	Lead Temperature (soldering, 10 sec.)	300°C
Logic to Emitter ( $V_L - V^-$ )	33V		
Reference to Emitter ( $V_R - V^-$ )	31V		
Reference to Input ( $V_R - V_{IN}$ )	6V		
Logic to Input ( $V_L - V_{IN}$ )	±6V		

**NOTE:** Dissipation rating assumes device is mounted with all leads welded or soldered to printed circuit board in ambient temperature of 70°C. Derate 10mW/°C for higher ambient temperature.

Stresses above those listed under Absolute Maximum Ratings may cause permanent damage to the device. These are stress ratings only, and functional operation of the device at these or any other conditions above those indicated in the operational sections of the specifications is not implied. Exposure to absolute maximum rating conditions for extended periods may affect device reliability.

**3**

**ELECTRICAL CHARACTERISTICS**

Test conditions unless specified otherwise are as follows:  $V_L = 4.5V$ ,  $V_R = 0$ ,  $V^- = -20V$ , and  $P = -20V$ . Input ON and OFF test conditions used for output and power supply specifications.

		PARAMETER (NOTE)	MAX LIMITS			UNITS	CONDITIONS
			-55°C	+25°C	+125°C		
INPUT	DG116	$I_{IN(OFF)}$	1	1	100	$\mu A$	$V_{IN} = 0.4V$
	DG123	$V_{IN(ON)}$	1.3	1.0	0.8	V	$I_{IN} = 1mA$
	DG118	$I_{IN(OFF)}$	1	1	20	$\mu A$	$V_{IN} = 4.1V$
	DG125	$I_{IN(ON)}$	-0.7	-0.7	-0.7	mA	$V_{IN} = 0.5V$
OUTPUT	All circuits	$r_{DS(ON)}$	100	100	125	$\Omega$	$V_D = 10V, I_S = -1mA$
			200	200	250	$\Omega$	$V_D = 0, I_S = -100\mu A$
			450	450	600	$\Omega$	$V_D = -10V, I_S = -100\mu A$
		$I_{D(ON)}$		4	4000	nA	$V_D = 10V, I_{S(all)} = 0$
		$I_{D(OFF)}$		-4	-4000	nA	$V_{S(all)} = 10V, V_D = -10V$
		$I_{S(OFF)}$		-1	-1000	nA	$V_D = 10V, V_S = -10V$
POWER SUPPLY	All circuits	$I_{CC(ON)}$		3		mA	One Channel (ON)
		$I_{L(ON)}$		3		mA	
		$I_{R(ON)}$		-0.5		mA	
		$I_{EE(ON)}$		-6		mA	
	All circuits	$I_{CC(OFF)}$		10		$\mu A$	All Channels (OFF)
		$I_{L(OFF)}$		10		$\mu A$	
		$I_{R(OFF)}$		-15		$\mu A$	
		$I_{EE(OFF)}$		-20		$\mu A$	
SWITCHING TIMES	All circuits	$t_{(ON)}$		0.3		$\mu s$	See Switching Times
		$t_{(OFF)}$		1		$\mu s$	

**NOTE:** (OFF) and (ON) subscript notation refers to the conduction state of the MOS-FET switch for the given test condition.

TYPICAL CHARACTERISTICS

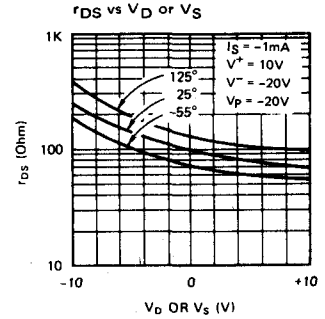
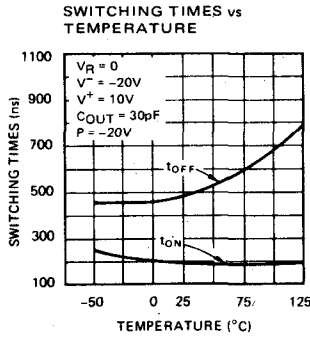
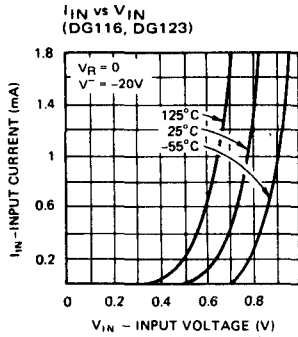

APPLICATION TIPS

The recommended resistor values for interfacing RTL, DTL, and T<sup>2</sup>L Logic are shown in Figures 1 and 2.

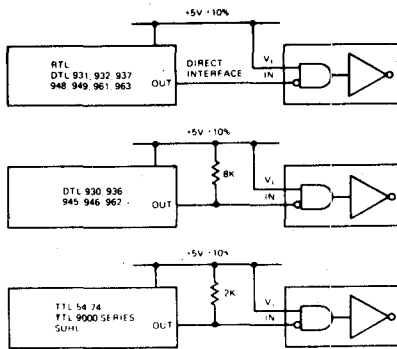

Figure 1. DG118 and DG125 Interface

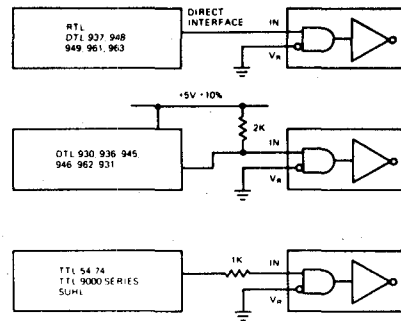

Figure 2. DG116 and DG123 Interface

3

Enable Control

The  $V_R$  and  $V_L$  terminals can be used as either a Strobe or an Enable control. The requirements for sinking current at  $V_R$  or sourcing current at  $V_L$  are:  $I_{L(ON)} \times \text{No. of channels used}$ , for DG118 and DG125, and  $I_{R(ON)} \times \text{No. of channels used}$ , for the DG116 and DG123 devices. The voltage at  $V_L$  must be greater than the voltage at  $V_{IN}$  by at least +4V.

SWITCHING TIMES

