

CD54/74HC354, CD54/74HCT354 CD54/74HC356, CD54/74HCT356

File Number 1690

High-Speed CMOS Logic

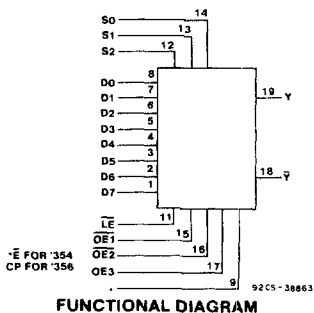

8-Input Multiplexer/Register, 3-State

CD54/74HC/HCT354 — Transparent Data & Select Latches
CD54/74HC/HCT356 — Edge-Triggered Data Flip-Flops
Transparent Select Latches

Type Features:

- Buffered inputs
- 3-State Complementary Outputs
- Bus Line Driving Capability
- Typical propagation delay: $V_{CC} = 5V, C_L = 15 pF, T_A = 25^\circ C$
 Data to Output (354) = 18 ns
 Clock to Output (356) = 22 ns

Family Features:

- Fanout (Over Temperature Range):
 Standard Outputs - 10 LSTTL Loads
 Bus Driver Outputs - 15 LSTTL Loads
- Wide Operating Temperature Range:
 CD74HC/HCT: -40 to $+85^\circ C$
- Balanced Propagation Delay and Transition Times
- Significant Power Reduction Compared to LSTTL Logic ICs
- Alternate Source is Philips/Signetics
- CD54HC/CD74HC Types:
 2 to 6 V Operation
 High Noise Immunity:
 $N_{IL} = 30\%, N_{IH} = 30\%$ of V_{CC} ; @ $V_{CC} = 5 V$
- CD54HCT/CD74HCT Types:
 4.5 to 5.5 V Operation
 Direct LSTTL Input Logic Compatibility
 $V_{IL} = 0.8 V$ Max., $V_{IH} = 2 V$ Min.
 CMOS Input Compatibility
 $I_i \leq 1 \mu A$ @ V_{OL}, V_{OH}

The RCA-CD54/74HC/HCT354 and CD54/74HC/HCT356 are data selectors/multiplexers that select one of eight sources. In both the HC/HCT354 and HC/HCT356 the data select bits S0, S1, and S2 are stored in transparent latches that are enabled by a low latch enable input, LE.

In the HC/HCT354 the data enable input, E, controls transparent latches that pass data to the outputs when E is high and latches in new data when E is low.

In the HC/HCT356 the data is stored in edge-triggered flip-flops that are triggered by a low-to-high clock transition.

In both types the three-state outputs are controlled by three output-enable inputs OE1, OE2, and OE3.

The CD54HC/HCT354/356 are supplied in 20-lead ceramic dual-in-line packages (F suffix). The CD74HC/HCT354/356 are supplied in 20-lead plastic dual-in-line plastic packages (E suffix). The CD54/74HC/HCT354/356 are also supplied in chip form (H suffix). The CD74HC/HCT354/356 are also available in plastic surface mounted packages (M suffix).

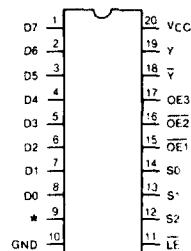

* E for 354
 CP for 356

TERMINAL ASSIGNMENT

CD54/74HC354, CD54/74HCT354 CD54/74HC356, CD54/74HCT356

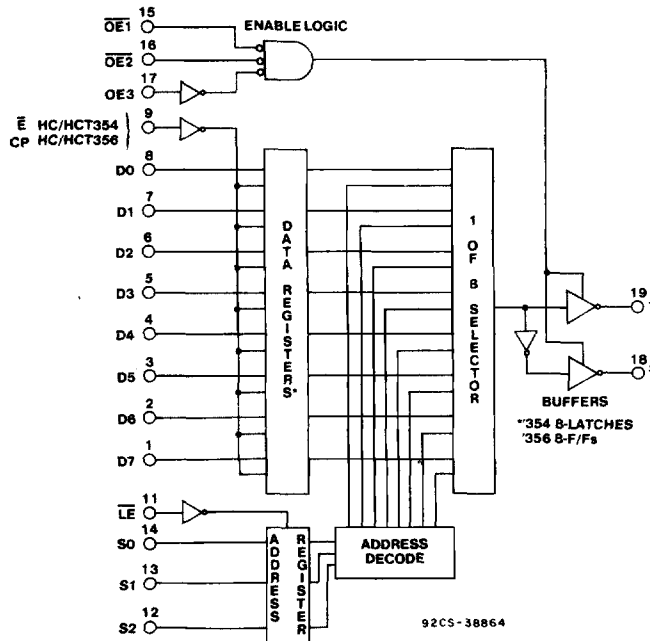

Block Diagram

TRUTH TABLE

Select #			Inputs			Output Enables			Outputs	
S2	S1	S0	Enable Data 'HC354 'HCT354	Clock 'HC356 'HCT356	OE1	OE2	OE3	Y	Y	
X	X	X	X	X	H	X	X	Z	Z	
X	X	X	X	X	X	H	X	Z	Z	
X	X	X	X	X	X	X	L	Z	Z	
L	L	L	L	↗	L	L	H	D0	D0	
L	L	L	H	Hor L	L	L	H	D0 _n	D0 _n	
L	L	H	L	↗	L	L	H	D1	D1	
L	L	H	H	Hor L	L	L	H	D1 _n	D1 _n	
L	H	L	L	↗	L	L	H	D2	D2	
L	H	L	H	Hor L	L	L	H	D2 _n	D2 _n	
L	H	H	L	↗	L	L	H	D3	D3	
L	H	H	H	Hor L	L	L	H	D3 _n	D3 _n	
H	L	L	L	↗	L	L	H	D4	D4	
H	L	L	H	Hor L	L	L	H	D4 _n	D4 _n	
H	L	H	L	↗	L	L	H	D5	D5	
H	L	H	H	Hor L	L	L	H	D5 _n	D5 _n	
H	H	L	L	↗	L	L	H	D6	D6	
H	H	L	H	Hor L	L	L	H	D6 _n	D6 _n	
H	H	H	L	↗	L	L	H	D7	D7	
H	H	H	H	Hor L	L	L	H	D7 _n	D7 _n	

Notes

- H = high level (steady state)
- L = low level (steady state)
- X = irrelevant (any input, including transitions)
- Z = high-impedance state (off state)
- ↗ = transition from low to high level
- D0 ... D7 = the level of steady-state inputs at inputs D0 through D7, respectively, at the time of the low-to-high clock transition in the case of HC356
- D0_n ... D7_n = the level of steady state inputs D0 through D7, respectively, before the most recent low-to-high transition of data control or clock
- # This column shows the input address setup with \overline{LE} low

CD54/74HC354, CD54/74HCT354 CD54/74HC356, CD54/74HCT356

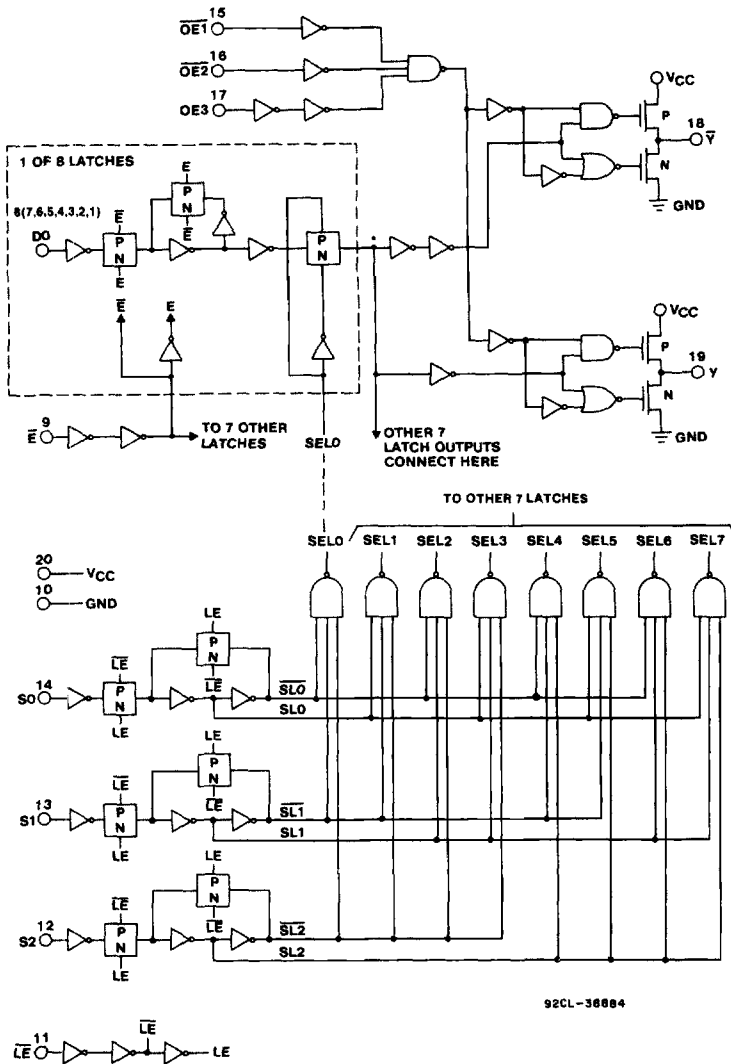

HC/HCT354 Logic Diagram

CD54/74HC354, CD54/74HCT354 CD54/74HC356, CD54/74HCT356

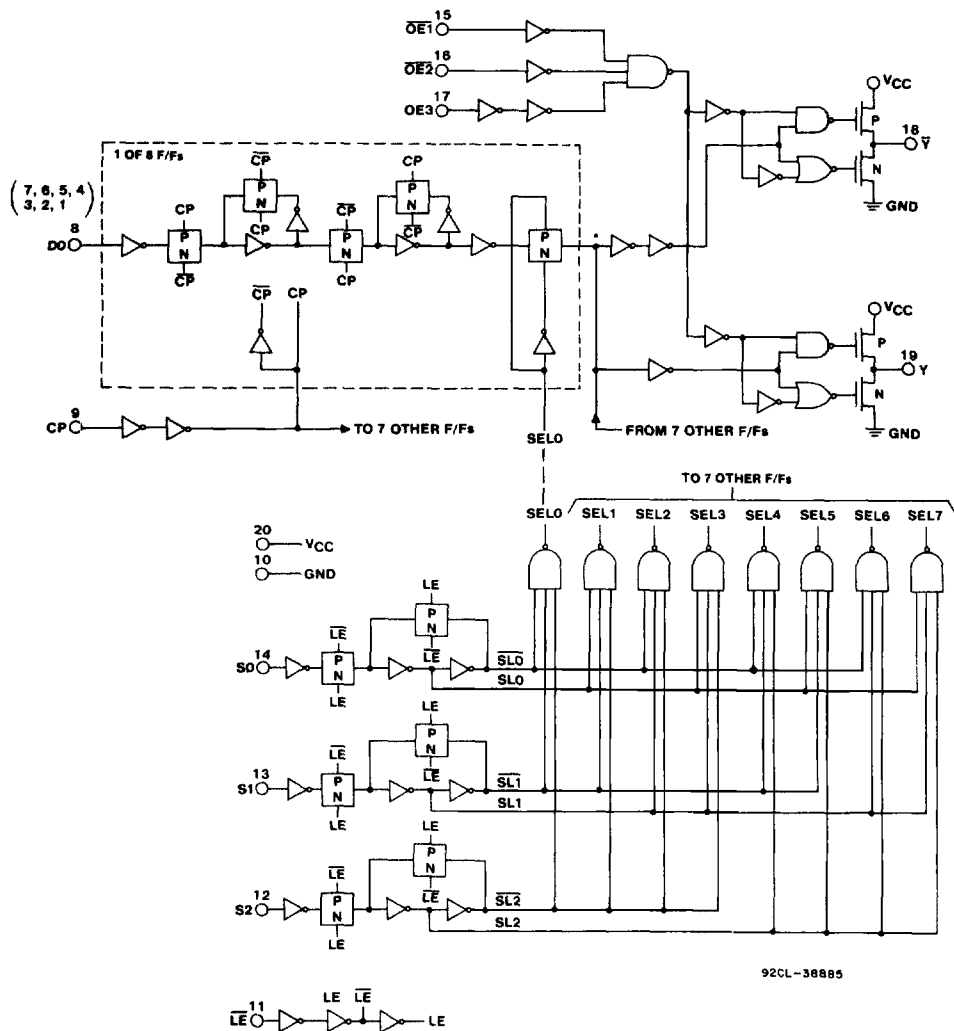

HC/HCT356 Logic Diagram

CD54/74HC354, CD54/74HCT354 CD54/74HC356, CD54/74HCT356

MAXIMUM RATINGS, Absolute-Maximum Values:

DC SUPPLY-VOLTAGE, (V_{CC}) (Voltages referenced to ground)	-0.5 to +7V
DC INPUT DIODE CURRENT, I_{IK} (FOR $V_i < -0.5$ V OR $V_i > V_{CC} + 0.5$ V)	± 20 mA
DC OUTPUT DIODE CURRENT, I_{OK} (FOR $V_o < -0.5$ V OR $V_o > 0.5$ V + V_{CC})	± 20 mA
DC DRAIN CURRENT, PER OUTPUT (I_o) (FOR -0.5 V < $V_o < V_{CC} + 0.5$ V)	± 35 mA
DC V_{CC} OR GROUND CURRENT (I_{CC})	± 70 mA
POWER DISSIPATION PER PACKAGE (P_D):	
For $T_A = -40$ to $+60^\circ$ C (PACKAGE TYPE E)	500 mW
For $T_A = +60$ to $+85^\circ$ C (PACKAGE TYPE E)	Derate Linearly at 8 mW/ $^\circ$ C to 300 mW
For $T_A = -55$ to $+100^\circ$ C (PACKAGE TYPE F, H)	500 mW
For $T_A = +100$ to $+125^\circ$ C (PACKAGE TYPE F, H)	Derate Linearly at 8 mW/ $^\circ$ C to 300 mW
For $T_A = -40$ to $+70^\circ$ C (PACKAGE TYPE M)	400 mW
For $T_A = +70$ to $+125^\circ$ C (PACKAGE TYPE M)	Derate Linearly at 6 mW/ $^\circ$ C to 70 mW
OPERATING-TEMPERATURE RANGE (T_A):	
PACKAGE TYPE F, H	-55 to $+125^\circ$ C
PACKAGE TYPE E, M	-40 to $+85^\circ$ C
STORAGE TEMPERATURE (T_{stg})	
	-65 to $+150^\circ$ C
LEAD TEMPERATURE (DURING SOLDERING):	
At distance $1/16 \pm 1/32$ in. (1.59 ± 0.79 mm) from case for 10 s max.	$+265^\circ$ C
Unit inserted into a PC Board (min. thickness $1/16$ in., 1.59 mm) with solder contacting lead tips only	$+300^\circ$ C

RECOMMENDED OPERATING CONDITIONS:

For maximum reliability, nominal operating conditions should be selected so that operation is always within the following ranges:

CHARACTERISTIC	LIMITS		UNITS
	MIN.	MAX.	
Supply-Voltage Range (For $T_A =$ Full Package Temperature Range) CD54/74HC Types CD54/74HCT Types	2 4.5	6 5.5	V
DC Input or Output Voltage V_i, V_o	0	V_{CC}	V
Operating Temperature T_A : CD74 Types CD54 Types	-40 -55	+85 +125	$^\circ$ C
Input Rise and Fall Times t_r, t_f at 2 V at 4.5 V at 6 V	0 0 0	1000 500 400	ns

*Unless otherwise specified, all voltages are referenced to Ground.

CD54/74HC354, CD54/74HCT354 CD54/74HC356, CD54/74HCT356

STATIC ELECTRICAL CHARACTERISTICS

CHARACTERISTIC	CD74HC354/356/CD54HC354/356										CD74HCT354/356/CD54HCT354/356										UNITS	
	TEST CONDITIONS			74HC/54HC TYPE			74HC TYPE		54HC TYPE			TEST CONDITIONS		74HCT/54HCT TYPE			74HCT TYPE		54HCT TYPE			
	V _I V	I _O mA	V _{CC} V	+25° C			-40/ +85° C		-55/ +125° C			V _I V	V _{CC} V	+25° C			-40/ +85° C		-55/ +125° C			
				Min	Typ	Max	Min	Max	Min	Max	Min			Typ	Max	Min	Max	Min	Max	Min		Max
High-Level Input Voltage V _{IH}			2	1.5	—	—	1.5	—	1.5	—	—	4.5	to	2	—	—	2	—	2	—	V	
			4.5	3.15	—	—	3.15	—	3.15	—	—	5.5										
			6	4.2	—	—	4.2	—	4.2	—												
Low-Level Input Voltage V _{IL}			2	—	—	0.5	—	0.5	—	0.5	—	4.5	to	—	—	0.8	—	0.8	—	0.8	V	
			4.5	—	—	1.35	—	1.35	—	1.35	—	5.5										
			6	—	—	1.8	—	1.8	—	1.8	—											
High-Level Output Voltage V _{OH}	V _{IL}	-0.02	2	1.9	—	—	1.9	—	1.9	—	V _{IL}	V _{IL}	4.5	4.4	—	—	4.4	—	4.4	—	V	
or			4.5	4.4	—	—	4.4	—	4.4	—	or	4.5	4.4	—	—	4.4	—	4.4	—	4.4	—	
CMOS Loads	V _{IH}		6	5.9	—	—	5.9	—	5.9	—	V _{IH}	V _{IH}										
TTL Loads (Bus Driver)	V _{IL}										V _{IL}	V _{IL}	4.5	3.98	—	—	3.84	—	3.7	—	V	
or		-6	4.5	3.98	—	—	3.84	—	3.7	—	or	4.5	3.98	—	—	3.84	—	3.7	—	3.7	—	
V _{IH}		-7.8	6	5.48	—	—	5.34	—	5.2	—	V _{IH}	V _{IH}										
Low-Level Output Voltage V _{OL}	V _{IL}	0.02	2	—	—	0.1	—	0.1	—	0.1	V _{IL}	V _{IL}	4.5	—	—	0.1	—	0.1	—	0.1	V	
or			4.5	—	—	0.1	—	0.1	—	0.1	—	or	4.5	—	—	0.1	—	0.1	—	0.1	—	
CMOS Loads	V _{IH}		6	—	—	0.1	—	0.1	—	0.1	—	V _{IH}	V _{IH}									
TTL Loads (Bus Driver)	V _{IL}										V _{IL}	V _{IL}	4.5	—	—	0.26	—	0.33	—	0.4	V	
or		6	4.5	—	—	0.26	—	0.33	—	0.4	or	4.5	—	—	0.26	—	0.33	—	0.4	—		
V _{IH}		7.8	6	—	—	0.26	—	0.33	—	0.4	V _{IH}	V _{IH}										
Input Leakage Current I _I	V _{CC}		6	—	—	±0.1	—	±1	—	±1	Any Voltage Between V _{CC} & Gnd	5.5	—	—	±0.1	—	±1	—	±1	—	±1	
or	Gnd																					
Quiescent Device Current I _{CC}	V _{CC}	0	6	—	—	8	—	80	—	160	V _{CC}	5.5	—	—	8	—	80	—	160	—	160	
or	Gnd																					
Additional Quiescent Device Current per input pin: 1 unit load ΔI _{CC} ¹											V _{CC} -2.1	4.5	to	—	100	360	—	450	—	490	μA	
												5.5										
3-State Leakage Current I _{OZ}	V _{IL} or V _{IH}	V _O = V _{CC} or Gnd	6	—	—	±0.5	—	±5.0	—	±10	V _{IL} or V _{IH}	5.5	—	—	±0.5	—	±5.0	—	±10	—	±10	μA

¹For dual-supply systems theoretical worst case (V_I = 2.4 V, V_{CC} = 5.5 V) specification is 1.8 mA.

CD54/74HC354, CD54/74HCT354 CD54/74HC356, CD54/74HCT356

HCT354 Input Loading Table

Input	Unit Loads*
D0-D7	0.50
S0, S1, S3	0.70
$\overline{OE}1, \overline{OE}2$	0.80
OE3	0.25
\overline{LE}	0.25
\overline{E}	0.60

*Unit Load is ΔI_{CC} limit specified in Static Characteristic Chart, e.g., 360 μA max. @ 25°C.

HCT356 Input Loading Table

Input	Unit Loads*
D0-D7	0.50
S0, S1, S3	0.70
$\overline{OE}1, \overline{OE}2$	0.80
OE3	0.25
\overline{LE}	0.25
CP	0.60

*Unit Load is ΔI_{CC} limit specified in Static Characteristic Chart, e.g., 360 μA max. @ 25°C.

SWITCHING CHARACTERISTICS ($V_{CC} = 5 V, T_A = 25^\circ C, \text{Input } t_r, t_f = 6 \text{ ns}$) — HC/HCT354

CHARACTERISTIC	C_L (pF)	SYMBOL	TYPICAL		UNITS
			54/74HC	54/74HCT	
Propagation Delay $D_n \rightarrow Y, \overline{Y}$	15	t_{PLH}, t_{PHL}	18	20	ns
$\overline{E} \rightarrow Y, \overline{Y}$	15	t_{PLH}, t_{PHL}	21	23	ns
$S_n \rightarrow Y, \overline{Y}$	15	t_{PLH}, t_{PHL}	22	25	ns
$\overline{LE} \rightarrow Y, \overline{Y}$	15	t_{PLH}, t_{PHL}	24	25	ns
Output Disabling Time	15	t_{PLZ}, t_{PHZ}	13	13, 16	ns
Output Enabling Time	15	t_{PZL}, t_{PZH}	12, 13	14	ns
Power Dissipation Capacitance*	—	C_{PD}	90	92	pF

* C_{PD} is used to determine the dynamic power consumption, per device.

$P_D = V_{CC}^2 f (C_{PD} + C_L)$ where:

f = input frequency.

C_L = output load capacitance.

V_{CC} = supply voltage

PREREQUISITE FOR SWITCHING FUNCTION — HC/HCT354

CHARACTERISTIC	SYMBOL	V_{CC}	25°C				-40°C to +85°C				-55°C to +125°C				UNITS
			HC		HCT		74HC		74HCT		54HC		54HCT		
			Min.	Max.	Min.	Max.	Min.	Max.	Min.	Max.	Min.	Max.	Min.	Max.	
\overline{E} pulse width	t_{PLH} t_{PHL}	2	80	—	—	100	—	—	—	120	—	—	—	ns	
		4.5	16	—	16	20	—	20	—	24	—	24	—		
		6	14	—	—	17	—	—	—	20	—	—	—		
\overline{LE} pulse width	t_{PLH} t_{PHL}	2	80	—	—	100	—	—	—	120	—	—	—	ns	
		4.5	16	—	16	20	—	20	—	24	—	24	—		
		6	14	—	—	17	—	—	—	20	—	—	—		
Set Up Times $D_n \rightarrow \overline{E}$	t_{SU}	2	50	—	—	65	—	—	—	75	—	—	—	ns	
		4.5	10	—	10	13	—	13	—	15	—	15	—		
		6	9	—	—	11	—	—	—	13	—	—	—		
$S_n \rightarrow \overline{LE}$	t_{SU}	2	50	—	—	65	—	—	—	75	—	—	—	ns	
		4.5	10	—	10	13	—	13	—	15	—	15	—		
		6	9	—	—	11	—	—	—	13	—	—	—		
Hold Times $D_n \rightarrow \overline{E}$	t_H	2	45	—	—	55	—	—	—	70	—	—	—	ns	
		4.5	9	—	9	11	—	11	—	14	—	14	—		
		6	8	—	—	9	—	—	—	12	—	—	—		
$S_n \rightarrow \overline{LE}$	t_H	2	45	—	—	55	—	—	—	70	—	—	—	ns	
		4.5	9	—	9	11	—	11	—	14	—	14	—		
		6	8	—	—	9	—	—	—	12	—	—	—		

CD54/74HC354, CD54/74HCT354 CD54/74HC356, CD54/74HCT356

SWITCHING CHARACTERISTICS ($C_L = 50 \text{ pF}$, Input $t_r, t_f = 6 \text{ ns}$) — HC/HCT354

CHARACTERISTIC	SYMBOL	V_{CC}	25°C				-40°C to +85°C				-55°C to +125°C				UNITS
			HC		HCT		74HC		74HCT		54HC		54HCT		
			Min.	Max.	Min.	Max.	Min.	Max.	Min.	Max.	Min.	Max.	Min.	Max.	
Propagation Delay, $D_n \rightarrow Y, \bar{Y}$	t_{PLH} t_{PHL}	2	—	210	—	—	—	265	—	—	—	315	—	—	ns
		4.5	—	42	—	47	—	53	—	59	—	63	—	71	
		6	—	36	—	—	—	45	—	—	—	54	—	—	
$\bar{E} \rightarrow Y, \bar{Y}$	t_{PLH} t_{PHL}	2	—	250	—	—	—	315	—	—	—	375	—	—	ns
		4.5	—	50	—	54	—	63	—	68	—	75	—	81	
		6	—	43	—	—	—	54	—	—	—	64	—	—	
$S_n \rightarrow Y, \bar{Y}$	t_{PLH} t_{PHL}	2	—	260	—	—	—	325	—	—	—	390	—	—	ns
		4.5	—	52	—	59	—	65	—	74	—	78	—	89	
		6	—	44	—	—	—	55	—	—	—	66	—	—	
$\bar{L}\bar{E} \rightarrow Y, \bar{Y}$	t_{PLH} t_{PHL}	2	—	290	—	—	—	365	—	—	—	435	—	—	ns
		4.5	—	58	—	63	—	73	—	79	—	87	—	94	
		6	—	49	—	—	—	62	—	—	—	74	—	—	
Output Disabling Time $\bar{O}E_n \rightarrow Y, \bar{Y}$	t_{PLZ}	2	—	155	—	—	—	195	—	—	—	235	—	—	ns
		4.5	—	31	—	33	—	39	—	41	—	47	—	50	
		6	—	26	—	—	—	33	—	—	—	40	—	—	
OE3 to Y, \bar{Y}	t_{PHZ}	2	—	155	—	—	—	195	—	—	—	235	—	—	ns
		4.5	—	31	—	39	—	39	—	49	—	47	—	59	
		6	—	26	—	—	—	33	—	—	—	40	—	—	
Output Enabling Time $\bar{O}E_n \rightarrow Y, \bar{Y}$	t_{PZL}	2	—	150	—	—	—	190	—	—	—	225	—	—	ns
		4.5	—	30	—	34	—	38	—	43	—	45	—	51	
		6	—	26	—	—	—	33	—	—	—	38	—	—	
OE3 to Y, \bar{Y}	t_{PZH}	2	—	160	—	—	—	200	—	—	—	240	—	—	ns
		4.5	—	32	—	34	—	40	—	43	—	48	—	51	
		6	—	27	—	—	—	34	—	—	—	41	—	—	
Output Transition Time	t_{TLH} t_{THL}	2	—	60	—	—	—	75	—	—	—	90	—	—	ns
		4.5	—	12	—	12	—	15	—	15	—	18	—	18	
		6	—	10	—	—	—	13	—	—	—	15	—	—	
Input Capacitance	C_i		—	10	—	10	—	10	—	10	—	10	—	10	pF
3-state Output Capacitance	C_o		—	20	—	20	—	20	—	20	—	20	—	20	pF

SWITCHING CHARACTERISTICS ($V_{CC} = 5 \text{ V}$, $T_A = 25^\circ \text{C}$, Input $t_r, t_f = 6 \text{ ns}$) — HC/HCT356

CHARACTERISTIC	C_L (pF)	SYMBOL	TYPICAL		UNITS
			54/74HC	54/74HCT	
Propagation Delay $CP \rightarrow Y, \bar{Y}$	15	t_{PLH}, t_{PHL}	22	22	ns
$S_n \rightarrow Y, \bar{Y}$	15	t_{PLH}, t_{PHL}	22	25	ns
$\bar{L}\bar{E} \rightarrow Y, \bar{Y}$	15	t_{PLH}, t_{PHL}	24	25	ns
Output Disabling Time	15	t_{PLZ}, t_{PHZ}	13	13, 15	ns
Output Enabling Time	15	t_{PZL}, t_{PZH}	12, 13	14	ns
Power Dissipation Capacitance*	—	C_{PD}	51	52	pF

* C_{PD} is used to determine the dynamic power consumption, per device.

$P_D = V_{CC}^2 f_i (C_{PD} + C_L)$ where:

f_i = input frequency.

C_L = output load capacitance.

V_{CC} = supply voltage.

CD54/74HC354, CD54/74HCT354 CD54/74HC356, CD54/74HCT356

PREREQUISITE FOR SWITCHING FUNCTION — HC/HCT356

CHARACTERISTIC	SYMBOL	V _{CC}	25°C				-40°C to +85°C				-55°C to +125°C				UNITS
			HC		HCT		74HC		74HCT		54HC		54HCT		
			Min.	Max.	Min.	Max.	Min.	Max.	Min.	Max.	Min.	Max.	Min.	Max.	
CP Pulse Width	t _{PLH} t _{PHL}	2	80	—	—	—	100	—	—	—	120	—	—	—	ns
		4.5	16	—	20	—	20	—	25	—	24	—	30	—	
		6	14	—	—	—	17	—	—	—	20	—	—	—	
LE Pulse Width	t _{PLH} t _{PHL}	2	80	—	—	—	100	—	—	—	120	—	—	—	ns
		4.5	16	—	20	—	20	—	25	—	24	—	30	—	
		6	14	—	—	—	17	—	—	—	20	—	—	—	
Set Up Times Dn → CP	t _{SU}	2	5	—	—	—	5	—	—	—	5	—	—	—	ns
		4.5	5	—	7	—	5	—	9	—	5	—	11	—	
		6	5	—	—	—	5	—	—	—	5	—	—	—	
Sn → LE	t _{SU}	2	5	—	—	—	5	—	—	—	5	—	—	—	ns
		4.5	5	—	7	—	5	—	9	—	5	—	11	—	
		6	5	—	—	—	5	—	—	—	5	—	—	—	
Hold Times Dn → CP	t _H	2	45	—	—	—	55	—	—	—	70	—	—	—	ns
		4.5	9	—	9	—	11	—	11	—	14	—	14	—	
		6	8	—	—	—	9	—	—	—	12	—	—	—	
Sn → LE	t _H	2	60	—	—	—	75	—	—	—	90	—	—	—	ns
		4.5	12	—	12	—	15	—	15	—	18	—	18	—	
		6	10	—	—	—	13	—	—	—	15	—	—	—	

SWITCHING CHARACTERISTICS (C_L = 50 pF, Input t_r, t_f = 6 ns) — HC/HCT356

CHARACTERISTIC	SYMBOL	V _{CC}	25°C				-40°C to +85°C				-55°C to +125°C				UNITS
			HC		HCT		74HC		74HCT		54HC		54HCT		
			Min.	Max.	Min.	Max.	Min.	Max.	Min.	Max.	Min.	Max.	Min.	Max.	
Propagation Delay: CP → Y, Ȳ	t _{PLH} t _{PHL}	2	—	255	—	—	—	320	—	—	—	385	—	—	ns
		4.5	—	51	—	51	—	64	—	64	—	77	—	77	
		6	—	43	—	—	—	54	—	—	—	65	—	—	
Sn → Y, Ȳ	t _{PLH} t _{PHL}	2	—	260	—	—	—	325	—	—	—	390	—	—	ns
		4.5	—	52	—	59	—	65	—	74	—	78	—	89	
		6	—	44	—	—	—	55	—	—	—	66	—	—	
LE → Y, Ȳ	t _{PLH} t _{PHL}	2	—	290	—	—	—	365	—	—	—	435	—	—	ns
		4.5	—	58	—	63	—	73	—	79	—	87	—	94	
		6	—	49	—	—	—	62	—	—	—	74	—	—	
Output Disabling Time OE1, OE2 to Y, Ȳ OE3 to Y, Ȳ	t _{PLZ} t _{PHZ}	2	—	155	—	—	—	195	—	—	—	235	—	—	ns
		4.5	—	31	—	33	—	39	—	41	—	47	—	50	
		6	—	26	—	—	—	33	—	—	—	40	—	—	
Output Enabling Time OE1, OE2 to Y, Ȳ OE3 to Y, Ȳ	t _{PZL} t _{PZH}	2	—	150	—	—	—	190	—	—	—	225	—	—	ns
		4.5	—	30	—	34	—	38	—	43	—	45	—	51	
		6	—	26	—	—	—	33	—	—	—	38	—	—	
Output Transition Time	t _{TLH} t _{THL}	2	—	60	—	—	—	75	—	—	—	90	—	—	ns
		4.5	—	12	—	12	—	15	—	15	—	18	—	18	
		6	—	10	—	—	—	13	—	—	—	15	—	—	
Input Capacitance	C _i		—	10	—	10	—	10	—	10	—	10	—	10	pF
3-state Output Capacitance	C _o		—	20	—	20	—	20	—	20	—	20	—	20	pF

CD54/74HC354, CD54/74HCT354 CD54/74HC356, CD54/74HCT356

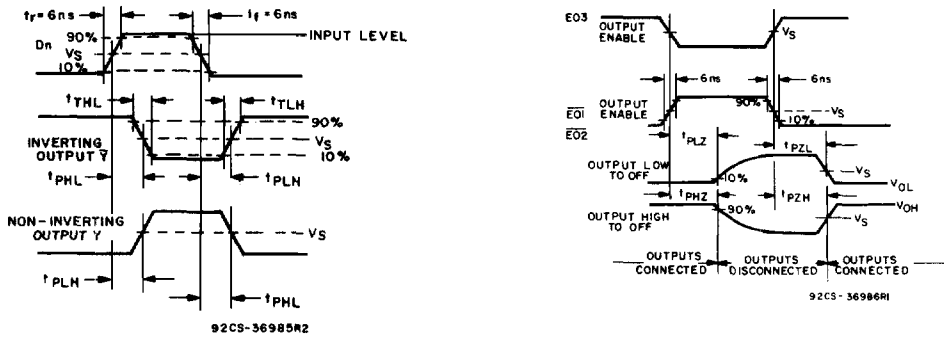

	54/74HC	54/74HCT
Input Level	V_{CC}	3 V
V_S	50% V_{CC}	1.3 V

Fig. 1 — Transition times and propagation delay times.

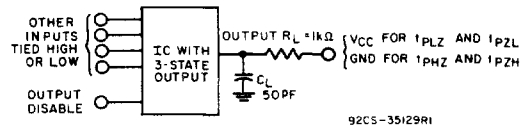

Fig. 2 — Three-state propagation delay test circuit.