

Molded Inductor



AMDLA1306Q Series

Request Samples



Check Inventory



13.5 x 12.6 x 6.2 mm
RoHS/RoHS II Compliant
MSL Level = 1

Features

- AEC-Q200 Qualified
- Shielded construction
- Soft saturation
- Low DCR per cubic mm
- Designed for switching frequencies between 100KHz-2MHz

Applications

- Body electronics and comfort system
- Infotainment and entertainment
- Electric vehicles
- Lighting
- Solar inverters and power
- Industrial and robotics
- Medium and high-power switch mode power supplies

Electrical Specifications

Part Number*	Inductance (uH)	Tolerance (%)	Irms Max (A)	Isat Max (A)	DC Resistance (mΩ)		E (mm) ± 0.3	Type
					Typ	Max		
AMDLA1306Q-R10NT	0.10	30	60	115	0.2	0.25	4.7	Non-Lead Frame
AMDLA1306Q-R22MT	0.22	20	42	105	0.4	0.46	4.7	Non-Lead Frame
AMDLA1306Q-R33MT	0.33	20	36	65	0.6	0.7	4.7	Non-Lead Frame
AMDLA1306Q-R68MT	0.68	20	33	46	1.25	1.5	4.0	Non-Lead Frame
AMDLA1306Q-1R0MT	1	20	29	36	1.50	1.8	4.0	Non-Lead Frame
AMDLA1306Q-1R5MT	1.5	20	25	30	2.20	2.53	4.0	Non-Lead Frame
AMDLA1306Q-1R8MT	1.8	20	23	27	3.20	3.6	4.7	Lead Frame
AMDLA1306Q-2R2MT	2.2	20	21	24	3.70	4.2	4.7	Lead Frame
AMDLA1306Q-2R7MT	2.7	20	20	23	4.2	5.0	4.7	Lead Frame
AMDLA1306Q-3R3MT	3.3	20	19	22.5	5.30	6.2	4.7	Lead Frame
AMDLA1306Q-4R7MT	4.7	20	17	21	6.80	8	4.7	Lead Frame
AMDLA1306Q-5R6MT	5.6	20	15	19.5	8.30	9.8	4.7	Lead Frame
AMDLA1306Q-6R8MT	6.8	20	14	18	9.80	11.3	4.7	Lead Frame
AMDLA1306Q-8R2MT	8.2	20	12.5	17	12	13.8	4.7	Lead Frame
AMDLA1306Q-100MT	10	20	11	15	13	15.8	4.7	Lead Frame
AMDLA1306Q-150MT	15	20	9.5	12	22	26	4.7	Lead Frame
AMDLA1306Q-220MT	22	20	8	9	31	35	4.7	Lead Frame
AMDLA1306Q-270MT	27	20	7.2	8	36	45	4.7	Lead Frame
AMDLA1306Q-330MT	33	20	6.5	8	46	55	4.7	Lead Frame
AMDLA1306Q-470MT	47	20	5.7	6.8	58	67	4.7	Lead Frame
AMDLA1306Q-680MT	68	20	4.8	5	82	100	4.7	Lead Frame
AMDLA1306Q-820MT	82	20	4	4.2	110	132	4.7	Lead Frame
AMDLA1306Q-101MT	100	20	3.8	4	140	161	4.7	Lead Frame

* Please refer to Part Identification Section

Test Conditions:

Inductance: 100KHz, 1 V, 0Adc,

Humidity Range: 85 ± 2% RH

Temperature Rise Current: Current measured when ΔT of 40°C

Saturation Current: Current measured when ΔL of 30%



5101 Hidden Creek Ln Spicewood TX 78669
Phone: 512-371-6159 | Fax: 512-351-8858
For terms and conditions of sales, please visit:
www.abracon.com

Revision: A 09-22-21

ABRACON IS
ISO9001-2015
CERTIFIED

Molded Inductor



AMDLA1306Q Series

Request Samples



Check Inventory



13.5 x 12.6 x 6.2 mm
RoHS/RoHS II Compliant
 MSL Level = 1

Electrical Specifications (Cont'd)

General Specifications:

Operating Temperature: -55°C to +155°C with (40°C rise) Irms current.

Maximum Part Temperature: +155°C

Tape and Reel packaging Temperature: <40°C, 60% RH

AMDLA1306Q series is **RoHS/ RoHS II Compliant and Pb free.**

AEC-Q200 Qualified

Mechanical Specifications

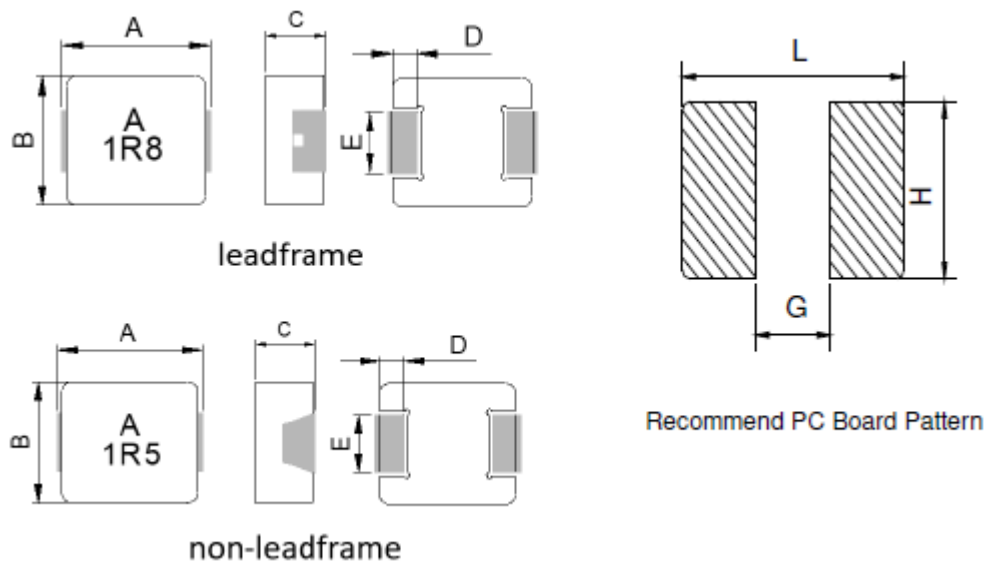

A	B	C	D	E	L	G	H
13.5±0.5	12.6±0.2	6.2±0.3	2.3±0.3	Refer to Spec table	14.5 Ref.	8.0 Ref.	5.0 Ref.

Dimensions: mm

Mechanical Specifications

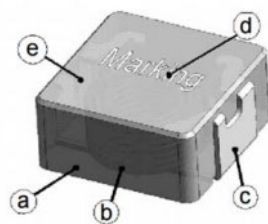

- (a) Core
- (b) Wire
- (c) Terminal
- (d) Ink
- (e) Paint

Molded Inductor



AMDLA1306Q Series

Request Samples



Check Inventory



13.5 x 12.6 x 6.2 mm
RoHS/RoHS II Compliant
MSL Level = 1

Part Identification

AMDLA1306Q -

Inductance Code
Refer to Electrical Specification table
E.g. 1R0

Tolerance
M: 20%
N: 30%

Packaging
T: 500 pcs/reel

Reflow Profile

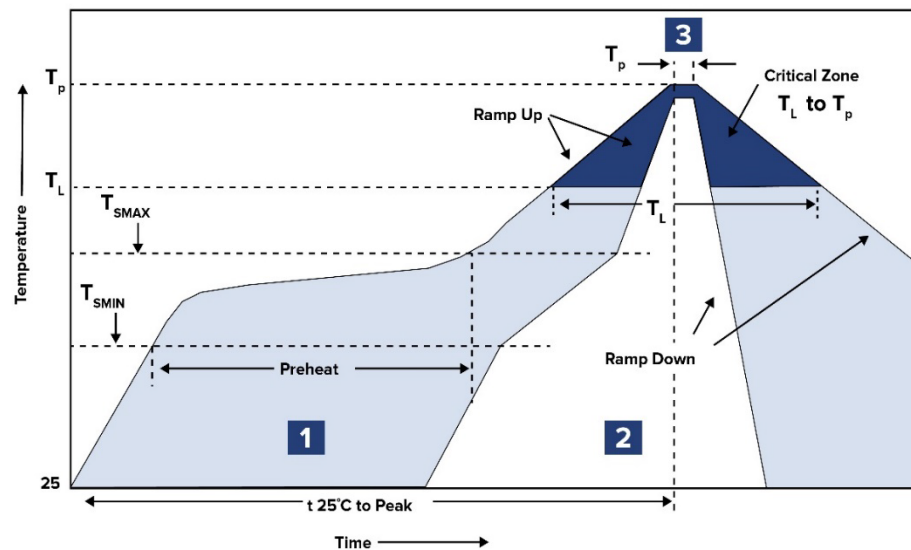

Zone	Description	Temperature	Times
1	Preheat	$T_{SMIN} \sim T_{SMAX}$ 150°C ~ 200°C	60 ~ 180 sec.
2	Reflow	T_L 217°C	60 ~ 150 sec.
3	Peak heat	T_P 260°C	10 sec. MAX

Molded Inductor



AMDLA1306Q Series

Request Samples



Check Inventory



13.5 x 12.6 x 6.2 mm
RoHS/RoHS II Compliant
MSL Level = 1

Packaging

T: Tape and Reel (500 pcs/reel)

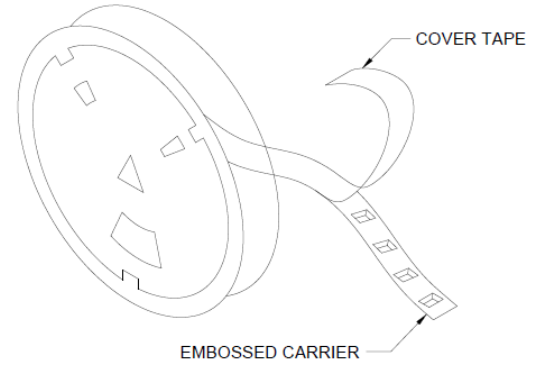
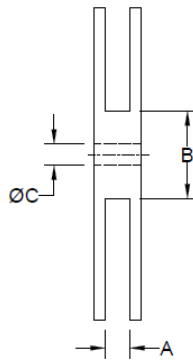
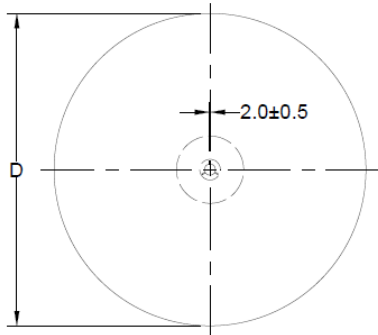

Type	A	B	C	D
13" x 24 mm	24.4 +2/-0	100 ± 2.0	13.5 +0.5/-0.2	330

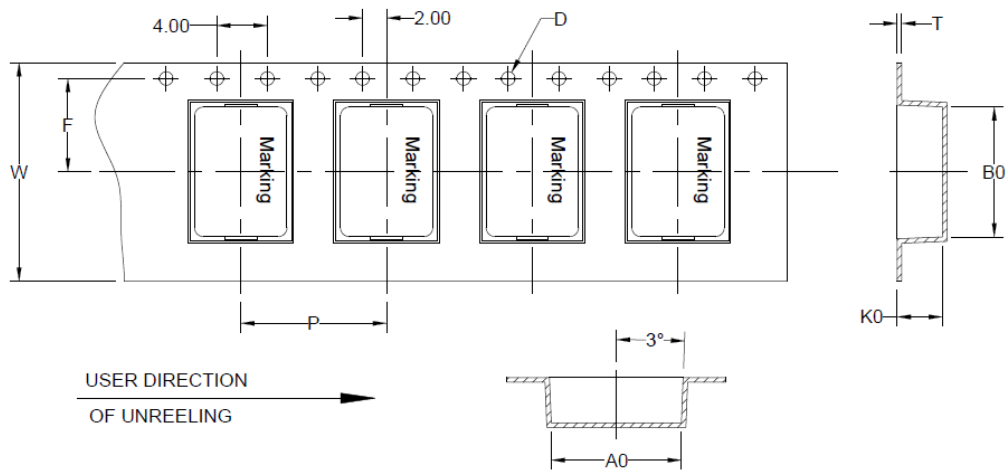

B ₀	A ₀	K ₀	P	W	F	T	D
14.1 ± 0.1	12.9 ± 0.1	7.0 ± 0.1	16.0 ± 0.1	24.0 ± 0.3	11.5 ± 0.1	0.35 ± 0.05	1.5 ± 0.1

Dimensions: mm

ATTENTION: Abracon LLC's products are COTS – Commercial-Off-The-Shelf products; suitable for Commercial, Industrial and, where designated, Automotive Applications. Abracon's products are not specifically designed for Military, Aviation, Aerospace, Life-dependent Medical applications or any application requiring high reliability where component failure could result in loss of life and/or property. For applications requiring high reliability and/or presenting an extreme operating environment, written consent and authorization from Abracon LLC is required. Please contact Abracon LLC for more information.



5101 Hidden Creek Ln Spicewood TX 78669
 Phone: 512-371-6159 | Fax: 512-351-8858
 For terms and conditions of sales, please visit:
www.abracon.com

Revision: A 09-22-21

ABRACON IS
 ISO9001-2015
 CERTIFIED