

Leiterplattenbohrbild
PCB drillhole pattern

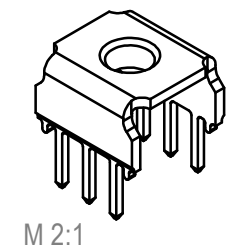

M 2:1

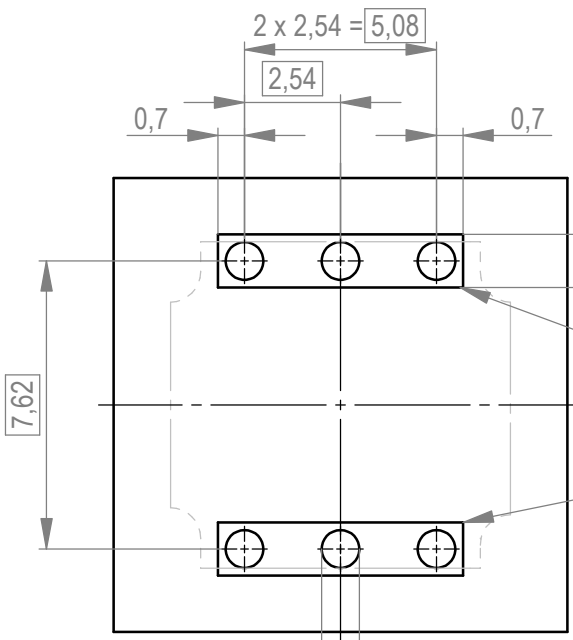

Dieser Bereich muß gleiches Potential auf der LP-Oberfläche haben
This area must have same electrical potential on surface of PCB

alle Löcher/
all holes
Ø 0,05
Ø 1 ±0,1

Weitergabe sowie Vervielfältigung dieses Dokuments, Verwertung und Mitteilung seines Inhalts sind verboten, soweit nicht ausdrücklich gestattet. Zuwiderhandlungen verpflichten zu Schadenersatz. Alle Rechte für den Fall der Patent-, Gebrauchsmuster- oder Geschmacksmustererhaltung vorbehalten. The reproduction, distribution and utilization of this document as well as the communication of its contents to others without express authorization is prohibited. Offenders will be held liable for the payment of damages. All rights reserved in the event of the grant of a patent, utility model or design.

Die deutsche Version dieser Zeichnung dient nur zur Erleichterung der Handhabung. Bei Abweichungen von dem englischen Original gilt das englische Original. The german version of this drawing has been offered for convenience only and may deviate from the english original. In case of any deviation the English version shall prevail.

214788-E	M4
214801-E	M3
214802-E	6-32UNC
214803-E	8-32UNC
Id.-Nr.: Part No.	Gewinde Thread

Dimension no.	Tolerances ISO 2768-FH ISO 8015	All Dimensions in mm	Scale 5:1
Customer drawing: This Drawing is a controlled Document.	Subject to modification without prior notice. Drawing will not be updated.		Material CuNi2Si Strip no.: 214376-E Drawing without plating
TE Connectivity		SVA 6-polig TL Power Bug 6 pin TL C-204821-E	
d1 Index	13.05.2023 Date	Class EPSVA	
		c A3	