

To our customers,

Old Company Name in Catalogs and Other Documents

On April 1st, 2010, NEC Electronics Corporation merged with Renesas Technology Corporation, and Renesas Electronics Corporation took over all the business of both companies. Therefore, although the old company name remains in this document, it is a valid Renesas Electronics document. We appreciate your understanding.

Renesas Electronics website: <http://www.renesas.com>

April 1st, 2010
Renesas Electronics Corporation

Issued by: Renesas Electronics Corporation (<http://www.renesas.com>)

Send any inquiries to <http://www.renesas.com/inquiry>.

Notice

1. All information included in this document is current as of the date this document is issued. Such information, however, is subject to change without any prior notice. Before purchasing or using any Renesas Electronics products listed herein, please confirm the latest product information with a Renesas Electronics sales office. Also, please pay regular and careful attention to additional and different information to be disclosed by Renesas Electronics such as that disclosed through our website.
2. Renesas Electronics does not assume any liability for infringement of patents, copyrights, or other intellectual property rights of third parties by or arising from the use of Renesas Electronics products or technical information described in this document. No license, express, implied or otherwise, is granted hereby under any patents, copyrights or other intellectual property rights of Renesas Electronics or others.
3. You should not alter, modify, copy, or otherwise misappropriate any Renesas Electronics product, whether in whole or in part.
4. Descriptions of circuits, software and other related information in this document are provided only to illustrate the operation of semiconductor products and application examples. You are fully responsible for the incorporation of these circuits, software, and information in the design of your equipment. Renesas Electronics assumes no responsibility for any losses incurred by you or third parties arising from the use of these circuits, software, or information.
5. When exporting the products or technology described in this document, you should comply with the applicable export control laws and regulations and follow the procedures required by such laws and regulations. You should not use Renesas Electronics products or the technology described in this document for any purpose relating to military applications or use by the military, including but not limited to the development of weapons of mass destruction. Renesas Electronics products and technology may not be used for or incorporated into any products or systems whose manufacture, use, or sale is prohibited under any applicable domestic or foreign laws or regulations.
6. Renesas Electronics has used reasonable care in preparing the information included in this document, but Renesas Electronics does not warrant that such information is error free. Renesas Electronics assumes no liability whatsoever for any damages incurred by you resulting from errors in or omissions from the information included herein.
7. Renesas Electronics products are classified according to the following three quality grades: “Standard”, “High Quality”, and “Specific”. The recommended applications for each Renesas Electronics product depends on the product’s quality grade, as indicated below. You must check the quality grade of each Renesas Electronics product before using it in a particular application. You may not use any Renesas Electronics product for any application categorized as “Specific” without the prior written consent of Renesas Electronics. Further, you may not use any Renesas Electronics product for any application for which it is not intended without the prior written consent of Renesas Electronics. Renesas Electronics shall not be in any way liable for any damages or losses incurred by you or third parties arising from the use of any Renesas Electronics product for an application categorized as “Specific” or for which the product is not intended where you have failed to obtain the prior written consent of Renesas Electronics. The quality grade of each Renesas Electronics product is “Standard” unless otherwise expressly specified in a Renesas Electronics data sheets or data books, etc.
 - “Standard”: Computers; office equipment; communications equipment; test and measurement equipment; audio and visual equipment; home electronic appliances; machine tools; personal electronic equipment; and industrial robots.
 - “High Quality”: Transportation equipment (automobiles, trains, ships, etc.); traffic control systems; anti-disaster systems; anti-crime systems; safety equipment; and medical equipment not specifically designed for life support.
 - “Specific”: Aircraft; aerospace equipment; submersible repeaters; nuclear reactor control systems; medical equipment or systems for life support (e.g. artificial life support devices or systems), surgical implantations, or healthcare intervention (e.g. excision, etc.), and any other applications or purposes that pose a direct threat to human life.
8. You should use the Renesas Electronics products described in this document within the range specified by Renesas Electronics, especially with respect to the maximum rating, operating supply voltage range, movement power voltage range, heat radiation characteristics, installation and other product characteristics. Renesas Electronics shall have no liability for malfunctions or damages arising out of the use of Renesas Electronics products beyond such specified ranges.
9. Although Renesas Electronics endeavors to improve the quality and reliability of its products, semiconductor products have specific characteristics such as the occurrence of failure at a certain rate and malfunctions under certain use conditions. Further, Renesas Electronics products are not subject to radiation resistance design. Please be sure to implement safety measures to guard them against the possibility of physical injury, and injury or damage caused by fire in the event of the failure of a Renesas Electronics product, such as safety design for hardware and software including but not limited to redundancy, fire control and malfunction prevention, appropriate treatment for aging degradation or any other appropriate measures. Because the evaluation of microcomputer software alone is very difficult, please evaluate the safety of the final products or system manufactured by you.
10. Please contact a Renesas Electronics sales office for details as to environmental matters such as the environmental compatibility of each Renesas Electronics product. Please use Renesas Electronics products in compliance with all applicable laws and regulations that regulate the inclusion or use of controlled substances, including without limitation, the EU RoHS Directive. Renesas Electronics assumes no liability for damages or losses occurring as a result of your noncompliance with applicable laws and regulations.
11. This document may not be reproduced or duplicated, in any form, in whole or in part, without prior written consent of Renesas Electronics.
12. Please contact a Renesas Electronics sales office if you have any questions regarding the information contained in this document or Renesas Electronics products, or if you have any other inquiries.

(Note 1) “Renesas Electronics” as used in this document means Renesas Electronics Corporation and also includes its majority-owned subsidiaries.

(Note 2) “Renesas Electronics product(s)” means any product developed or manufactured by or for Renesas Electronics.

PREAMPLIFIER FOR INFRARED REMOTE CONTROL

DESCRIPTION

The μ PC2800A is a receiver preamplifier for infrared remote control systems. It can be directly connected to a PIN photodiode and integrates a high-gain first-stage amplifier, limiter, bandpass filter, detection circuit, and waveform shaping circuit to provide a receiver preamplifier on a single chip.

FEATURES

- High reliability due to high-frequency lighting fluorescent lamp
Internal trap circuit
- Internal bandpass filter
Central frequency variable by external resistor: $f_0 = 30$ to 80 kHz
Few variation of central frequency thanks to f_0 trimming
- Low external components
Internal output pull-up resistor and power supply filter resistor
Only low external capacitance required
- ABLC (Automatic Bias Level Control) circuit
Controls fluctuation of bias level cause by disturbance from external light
- Open-collector output
Open-collector output (active low) with pull-up resistor (33 k Ω TYP.)

★ ORDERING INFORMATION

Part Number	Package
μ PC2800AGR	8-pin plastic SOP (225 mil)

The information in this document is subject to change without notice. Before using this document, please confirm that this is the latest version.
Not all devices/types available in every country. Please check with local NEC representative for availability and additional information.

BLOCK DIAGRAM

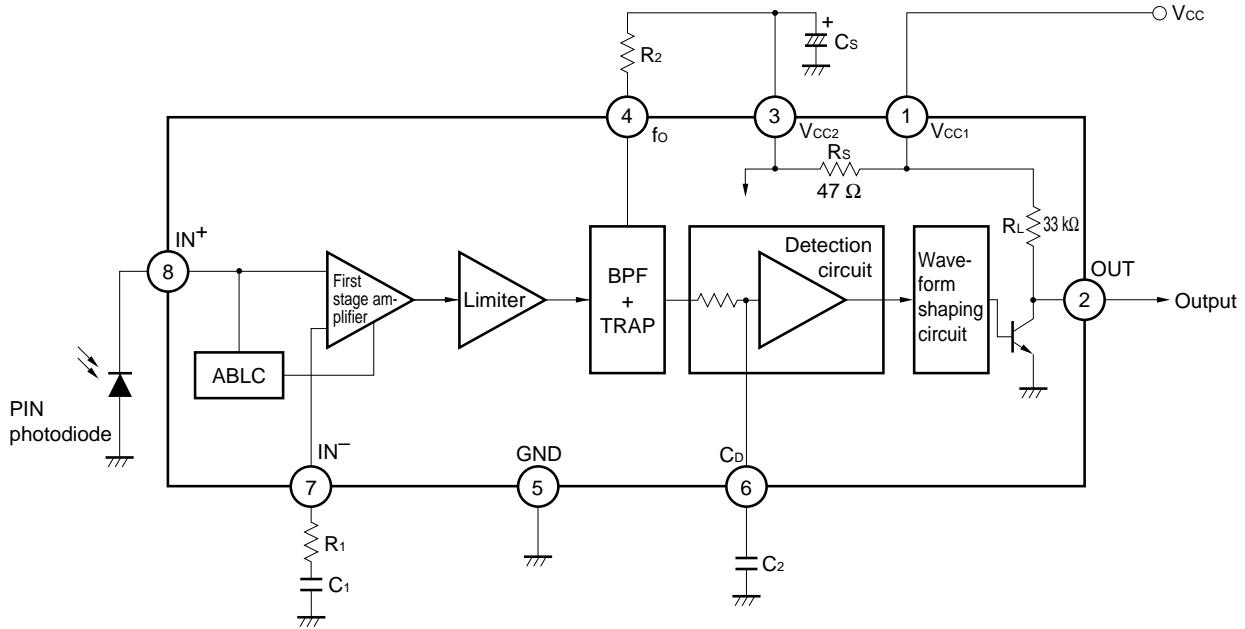

PIN CONFIGURATION (Top View)

8-pin plastic SOP (225 mil)

- μ PC2800AGR

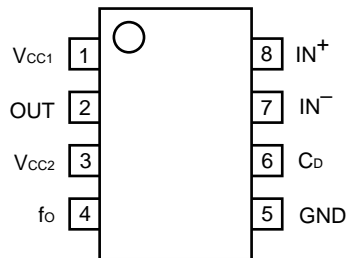

Pin No.	Symbol	Pin Name
1	V _{cc1}	Power input pin
2	OUT	Output pin
3	V _{cc2}	Power output pin
4	f _o	BPF frequency setting pin
5	GND	Ground pin
6	C _d	Detection capacitor connection pin
7	IN ⁻	First-stage amplifier gain setting pin
8	IN ⁺	Signal input pin

1. PIN FUNCTION

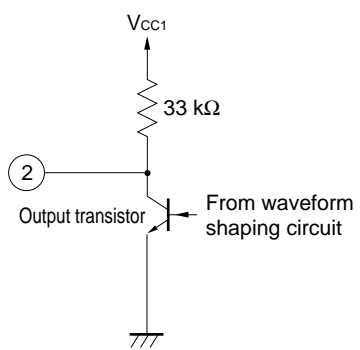
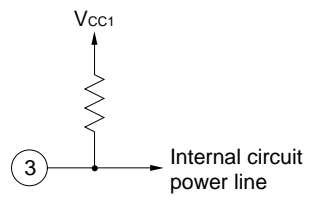
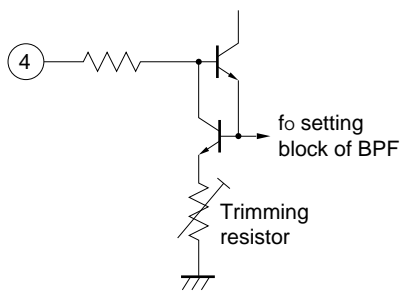
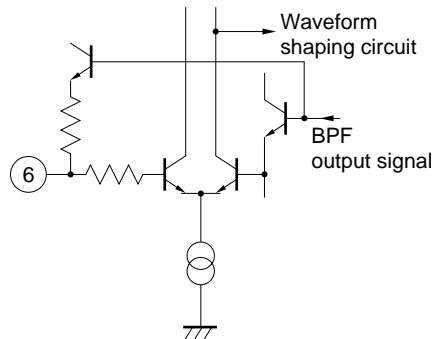
Pin No.	Symbol	Pin Name	Internal Equivalent Circuit	Function
1	V _{CC1}	Power input pin		Supply a voltage of 5 V \pm 10% to this pin. If the IC malfunctions due to power noise, connect a bypass capacitor.
2	OUT	Output pin		An open-collector output pin (active low) with a pull-up resistor (33 k Ω TYP.) Connect an external pull-up resistor of 2.2 k Ω or more, if any, to this pin.
3	V _{CC2}	Power output pin		Connect a capacitor of 47 μ F or so to this pin to stabilize the supply voltage to the internal circuit.
4	f _o	BPF frequency setting pin		Sets the central frequency of the internal bandpass filter by an external resistance (refer to f _o vs. R ₂ Characteristics in CHARACTERISTIC CURVE). Use a resistor with excellent accuracy and temperature characteristics.
5	GND	Ground pin		GND pin
6	C _D	Detection capacitor connection pin		Connect a smoothing capacitor to this pin to obtain a DC voltage corresponding to the output signal level of the internal bandpass filter. The 0.01 μ F is the most suitable value for the external capacitor between pin 6 and GND. In case of reducing this capacitor, confirm that the output pulses from pin 2 have enough width even if the longest burst signal is inputted.

★

Pin No.	Symbol	Pin Name	Internal Equivalent Circuit	Function
7	IN ⁻	First-stage gain setting pin		<p>Reverse input pin of the first-stage amplifier.</p> <p>Connect a capacitor (0.01 μF) to prevent direct current so that the first-stage amplifier operates as an AC amplifier. The gain of the amplifier can be adjusted by an external resistor (0 to 1 kΩ) (refer to A_v vs. R₁ Characteristics in CHARACTERISTIC CURVE).</p>
8	IN ⁺	Signal input pin		<p>This pin has an internal impedance of 90 kΩ (TYP.) and can be directly connected to a PIN photodiode. Because this is the input pin of a high-sensitivity amplifier, exercise care that noise is not superimposed on this pin. Keep the wiring length of the cathode of the PIN photodiode as short as possible.</p>

2. EXAMPLE OF MEASURES TO PREVENT MALFUNCTIONING DUE TO NOISE

2.1 Radiation noise

- Keep the wiring length between the PIN photodiode and pin 8 as short as possible.
- Keep the signal lines of pins 2 and 6 as far away as possible from those of pins 7 and 8.
- Commonly ground the anode of the PIN photodiode and the external capacitor connected to pin 7. Separate the GND and power GND of pin 6 from these.
- Cover the entire circuit in a shield case.

2.2 Power noise

- Monitor the noise superimposed on pin 3 with an oscilloscope. If high-frequency noise is superimposed, connect a ceramic capacitor of 0.1 μ F or so between pin 3 and GND. If low-frequency noise is superimposed, increase the capacitance of the capacitor between pin 3 and GND. If necessary, connect a capacitor between pin 1 and GND.

2.3 External light disturbance noise

- Use a PIN photodiode with an excellent spectral sensitivity.
- Use a PIN photodiode with a lens and with a narrow directional angle.

2.4 Noise

- Insert an external resistor (R_1 : 1 k Ω or less) in series to C_1 between pin 7 and GND to decrease the voltage gain. In this case, however, the distance is shortened and care must be exercised not to decrease the voltage gain too much.

★ 3. NOTICE FOR USE

The μ PC2800A is designed for the infrared remote control receivers of audio-visual equipment, air conditioner and so on. Therefore the μ PC2800A may not be suitable for some applications that require accurate pulse widths such as data communications. In case of using the μ PC2800A under the accurate pulse width condition, confirm that the output pulses from pin 2 have enough accuracy in actual environmental changing (refer to the following examples).

Example of environmental changing:

Operating ambient temperature, supply voltage, external disturbing light, external noise, input burst length, input carrier frequency, strength of input light, direction of input light, distance from transmitter, characteristics of parts (including the μ PC2800A) and so on.

4. ELECTRICAL SPECIFICATIONS

Absolute Maximum Ratings (T_A = 25 °C)

Parameter	Symbol	Rating	Unit
Supply voltage	V _{CC}	6.0	V
Output current	I _{OUT}	2.5	mA
Input voltage	V _{IN}	0 to V _{CC}	V
Permissible package loss	P _D	270	mW
Operating temperature	T _A	-20 to +75	°C
Storage temperature	T _{stg}	-40 to +125	°C

Caution If any of the parameters exceeds the absolute maximum ratings, even momentarily, the quality of the product may be impaired. The absolute maximum ratings are values that may physically damage the product(s). Be sure to use the product(s) within the ratings.

Recommended Operating Range

Parameter	Symbol	MIN.	TYP.	MAX.	Unit
Supply voltage	V _{CC}	4.5	5.0	5.5	V
Input frequency	f _{IN}	30	38	80	kHz

Electrical Characteristics (T_A = 25 °C, V_{CC} = 5.0 V)

Parameter	Symbol	Condition	MIN.	TYP.	MAX.	Unit
Supply current	I _{CC}			2.1	2.8	mA
Input pin voltage	V _{IN1}	I _{IN} = 0	2.0	2.5	3.1	V
Input pin voltage	V _{IN2}	I _{IN} = -300 μA	0.6	0.8	1.7	V
Voltage gain	A _V	f _{IN} = 38 kHz CW, V _{IN} = 30 μV _{p-p}	74	78	82	dB
BPF bandwidth	f _{BW}	-3 dB bandwidth, V _{IN} = 30 μV _{p-p} , R ₂ = 130 kΩ	2.0	2.5	3.0	kHz
Internal input resistance	r _{IN}	f _{IN} = 38 kHz CW, V _{IN} = 0.2 V _{p-p}	60	90	140	kΩ
Output pulse width 1	t _{PW1}	f _{IN} = 38 kHz burst wave, V _{IN} = 500 μV _{p-p} ^{Note}	440		770	μs
Output pulse width 2	t _{PW2}	f _{IN} = 38 kHz burst wave, V _{IN} = 50 mV _{p-p} ^{Note}	440		770	μs
Low-level output voltage	V _{OL}			0.2	0.4	V
High-level output voltage	V _{OH}		4.8	5.0		V

Note

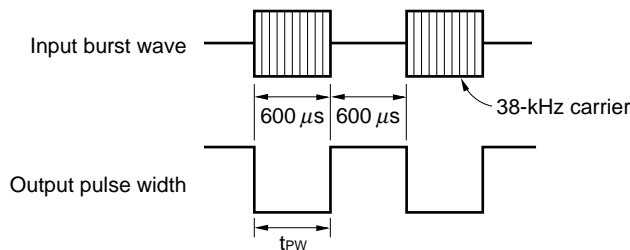

CHARACTERISTIC CURVE (T_A = 25 °C)

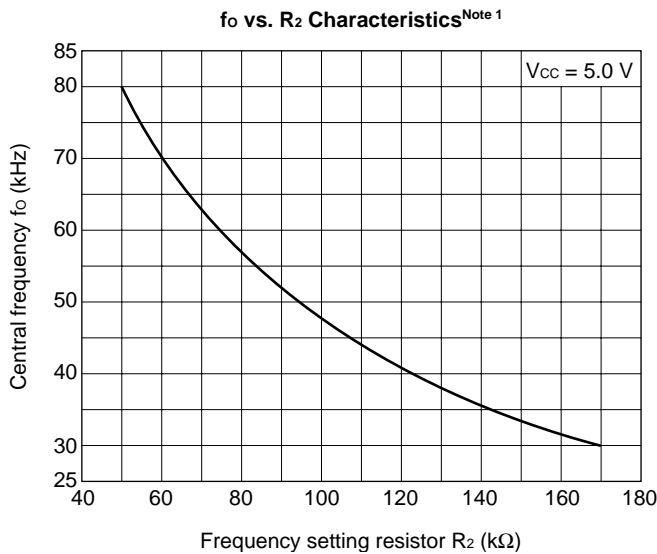
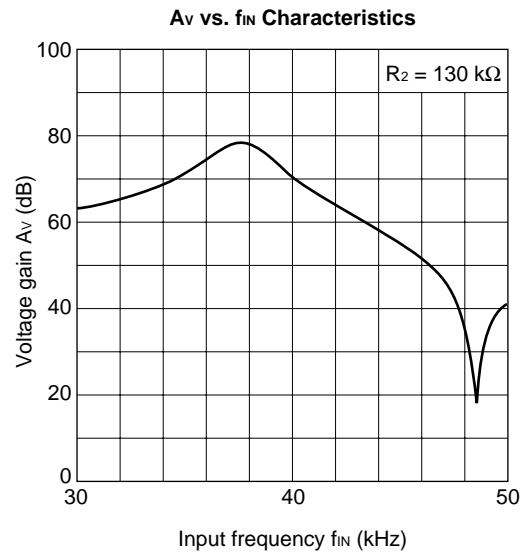
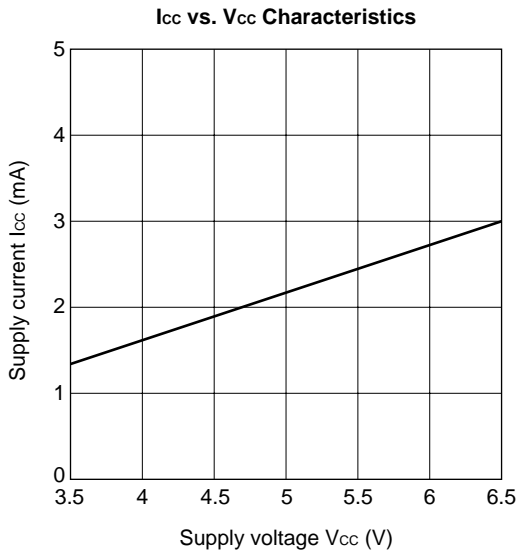

Note 1. The relation between f_o and R₂ (recommended value) is as follows:

f _o (kHz)	R ₂ (recommended value) (kΩ)
32.7	155
36.0	139
36.7	136
38.0	130
40.0	123
56.7	80
70.0	60

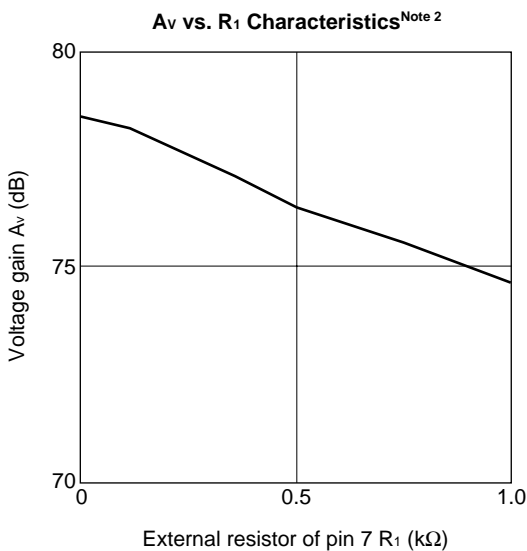

Note 2. This is the value of a resistor that is externally connected as follows:

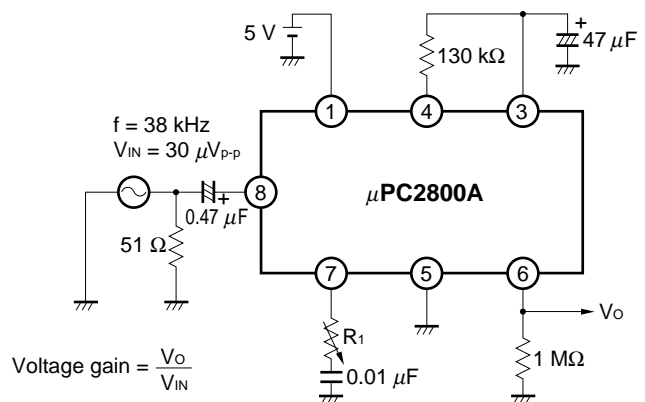

5. APPLICATION CIRCUIT EXAMPLE (fo = 38 kHz)

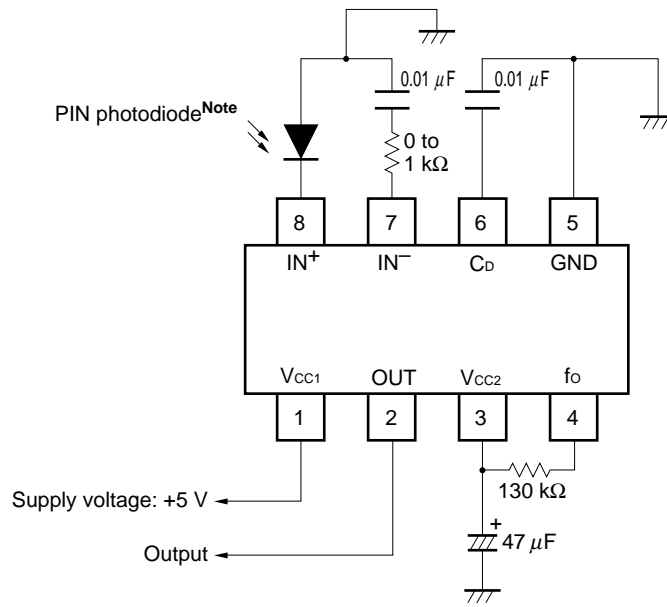

Note PH302, 302C, 310, 320, etc.

6. PACKAGE DRAWINGS

8 PIN PLASTIC SOP (225 mil)

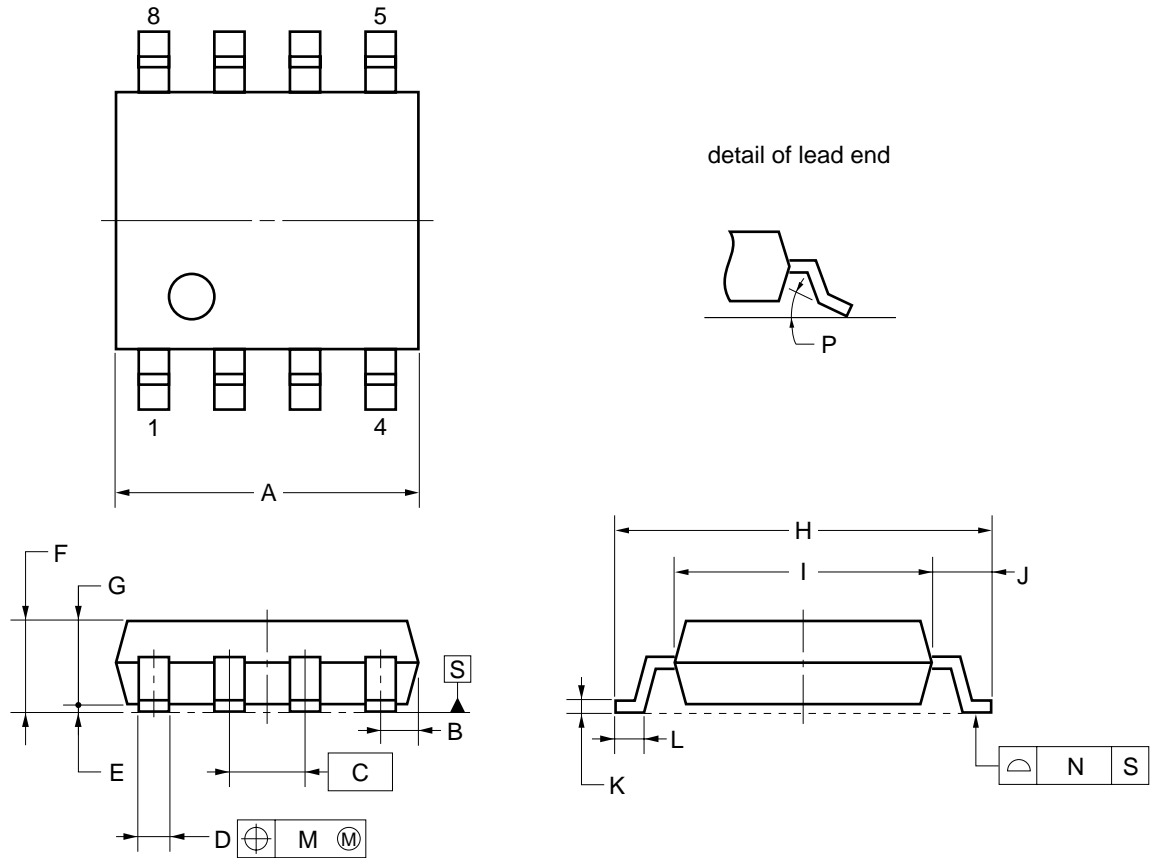

NOTE
 Each lead centerline is located within 0.12 mm of its true position (T.P.) at maximum material condition.

ITEM	MILLIMETERS
A	5.2 ^{+0.17} _{-0.20}
B	0.78 MAX.
C	1.27 (T.P.)
D	0.42 ^{+0.08} _{-0.07}
E	0.1±0.1
F	1.59±0.21
G	1.49
H	6.5±0.3
I	4.4±0.15
J	1.1±0.2
K	0.17 ^{+0.08} _{-0.07}
L	0.6±0.2
M	0.12
N	0.10
P	3° ^{+7°} _{-3°}

S8GM-50-225B-5

7. RECOMMENDED SOLDERING CONDITIONS

Solder this product under the following recommended conditions.

For details of the recommended soldering conditions, refer to information document **Semiconductor Device Mounting Technology Manual (C10535E)**.

For soldering methods and conditions other than those recommended, consult NEC.

Surface Mount Type

μPC2800AGR: 8-pin plastic SOP (225 mil)

Process	Conditions	Symbol
Infrared ray reflow	Peak temperature: 230 °C or below (Package surface temperature), Reflow time: 30 seconds or less (at 210 °C or higher), Maximum number of reflow processes: 1 time.	IR30-00-1
VPS	Peak temperature: 215 °C or below (Package surface temperature), Reflow time: 40 seconds or less (at 200 °C or higher), Maximum number of reflow processes: 1 time.	VP15-00-1
Wave soldering	Solder temperature: 260 °C or below, Flow time: 10 seconds or less, Maximum number of flow processes: 1 time, Pre-heating temperature: 120 °C or below (Package surface temperature).	WS60-00-1
Partial heating method	Pin temperature: 300 °C or below, Heat time: 3 seconds or less (Per each side of the device).	—

Caution Apply only one kind of soldering condition to a device, except for “partial heating method”, or the device will be damaged by heat stress.

[MEMO]

[MEMO]

• **The information in this document is current as of October, 1998. The information is subject to change without notice. For actual design-in, refer to the latest publications of NEC's data sheets or data books, etc., for the most up-to-date specifications of NEC semiconductor products. Not all products and/or types are available in every country. Please check with an NEC sales representative for availability and additional information.**

- No part of this document may be copied or reproduced in any form or by any means without prior written consent of NEC. NEC assumes no responsibility for any errors that may appear in this document.
- NEC does not assume any liability for infringement of patents, copyrights or other intellectual property rights of third parties by or arising from the use of NEC semiconductor products listed in this document or any other liability arising from the use of such products. No license, express, implied or otherwise, is granted under any patents, copyrights or other intellectual property rights of NEC or others.
- Descriptions of circuits, software and other related information in this document are provided for illustrative purposes in semiconductor product operation and application examples. The incorporation of these circuits, software and information in the design of customer's equipment shall be done under the full responsibility of customer. NEC assumes no responsibility for any losses incurred by customers or third parties arising from the use of these circuits, software and information.
- While NEC endeavours to enhance the quality, reliability and safety of NEC semiconductor products, customers agree and acknowledge that the possibility of defects thereof cannot be eliminated entirely. To minimize risks of damage to property or injury (including death) to persons arising from defects in NEC semiconductor products, customers must incorporate sufficient safety measures in their design, such as redundancy, fire-containment, and anti-failure features.
- NEC semiconductor products are classified into the following three quality grades:
"Standard", "Special" and "Specific". The "Specific" quality grade applies only to semiconductor products developed based on a customer-designated "quality assurance program" for a specific application. The recommended applications of a semiconductor product depend on its quality grade, as indicated below. Customers must check the quality grade of each semiconductor product before using it in a particular application.
 - "Standard": Computers, office equipment, communications equipment, test and measurement equipment, audio and visual equipment, home electronic appliances, machine tools, personal electronic equipment and industrial robots
 - "Special": Transportation equipment (automobiles, trains, ships, etc.), traffic control systems, anti-disaster systems, anti-crime systems, safety equipment and medical equipment (not specifically designed for life support)
 - "Specific": Aircraft, aerospace equipment, submersible repeaters, nuclear reactor control systems, life support systems and medical equipment for life support, etc.

The quality grade of NEC semiconductor products is "Standard" unless otherwise expressly specified in NEC's data sheets or data books, etc. If customers wish to use NEC semiconductor products in applications not intended by NEC, they must contact an NEC sales representative in advance to determine NEC's willingness to support a given application.

(Note)

- (1) "NEC" as used in this statement means NEC Corporation and also includes its majority-owned subsidiaries.
- (2) "NEC semiconductor products" means any semiconductor product developed or manufactured by or for NEC (as defined above).