

June 1997

6A, 600V, UFS Series N-Channel IGBTs

Features

- 6A, 600V at $T_C = 25^\circ\text{C}$
- 600V Switching SOA Capability
- Typical Fall Time 130ns at $T_J = 150^\circ\text{C}$
- Short Circuit Rating
- Low Conduction Loss

Ordering Information

| PART NUMBER | PACKAGE | BRAND |
|-------------|----------|--------|
| HGTD3N60C3 | TO-251AA | G3N60C |
| HGTD3N60C3S | TO-252AA | G3N60C |

NOTE: When ordering, use the entire part number. Add the suffix 9A to obtain the TO-252AA variant in Tape and Reel, i.e. HGTD3N60C3S9A.

Description

The HGTD3N60C3 and HGTD3N60C3S are MOS gated high voltage switching devices combining the best features of MOSFETs and bipolar transistors. These devices have the high input impedance of a MOSFET and the low on-state conduction loss of a bipolar transistor. The much lower on-state voltage drop varies only moderately between 25°C and 150°C .

The IGBT is ideal for many high voltage switching applications operating at moderate frequencies where low conduction losses are essential, such as: AC and DC motor controls, power supplies and drivers for solenoids, relays and contactors.

Formerly developmental type TA49113.

Symbol

N-CHANNEL ENHANCEMENT MODE

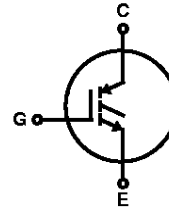

Packaging

JEDEC TO-251AA

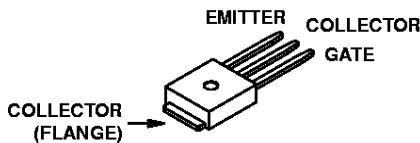

JEDEC TO-252AA

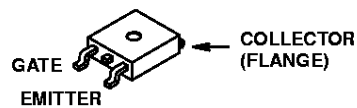

HARRIS SEMICONDUCTOR IGBT PRODUCT IS COVERED BY ONE OR MORE OF THE FOLLOWING U.S. PATENTS:

| | | | | | | | |
|-----------|-----------|-----------|-----------|-----------|-----------|-----------|-----------|
| 4,364,073 | 4,417,385 | 4,430,792 | 4,443,931 | 4,466,176 | 4,516,143 | 4,532,534 | 4,567,641 |
| 4,587,713 | 4,598,461 | 4,605,948 | 4,618,872 | 4,620,211 | 4,631,564 | 4,639,754 | 4,639,762 |
| 4,641,162 | 4,644,637 | 4,682,195 | 4,684,413 | 4,694,313 | 4,717,679 | 4,743,952 | 4,783,690 |
| 4,794,432 | 4,801,986 | 4,803,533 | 4,809,045 | 4,809,047 | 4,810,665 | 4,823,176 | 4,837,606 |
| 4,860,080 | 4,883,767 | 4,888,627 | 4,890,143 | 4,901,127 | 4,904,609 | 4,933,740 | 4,963,951 |

HGTD3N60C3, HGTD3N60C3S

Absolute Maximum Ratings $T_C = 25^\circ\text{C}$

| | HGTD3N60C3 | HGTD3N60C3S | UNITS |
|---|-------------|-------------|---------------------|
| Collector to Emitter Voltage | 600 | | V |
| Collector Current Continuous | | | |
| At $T_C = 25^\circ\text{C}$ | 6 | | A |
| At $T_C = 110^\circ\text{C}$ | 3 | | A |
| Collector Current Pulsed (Note 1) | 24 | | A |
| Gate to Emitter Voltage Continuous | ± 20 | | V |
| Gate to Emitter Voltage Pulsed | ± 30 | | V |
| Switching Safe Operating Area at $T_J = 150^\circ\text{C}$, Figure 14 | 18A at 480V | | |
| Power Dissipation Total at $T_C = 25^\circ\text{C}$ | 33 | | W |
| Power Dissipation Derating $T_C > 25^\circ\text{C}$ | 0.27 | | W/ $^\circ\text{C}$ |
| Reverse Voltage Avalanche Energy | 100 | | mJ |
| Operating and Storage Junction Temperature Range | -40 to 150 | | $^\circ\text{C}$ |
| Maximum Lead Temperature for Soldering | 260 | | $^\circ\text{C}$ |
| Short Circuit Withstand Time (Note 2) at $V_{GE} = 10\text{V}$, Figure 6 | 8 | | μs |

NOTES:

1. Repetitive Rating: Pulse width limited by maximum junction temperature.
2. $V_{CE(PK)} = 360\text{V}$, $T_J = 125^\circ\text{C}$, $R_{GE} = 82\Omega$.

Electrical Specifications $T_C = 25^\circ\text{C}$, Unless Otherwise Specified

| PARAMETER | SYMBOL | TEST CONDITIONS | MIN | TYP | MAX | UNITS | |
|---|-----------------|--|----------------------------|-----|-----------|---------------|--------------------|
| Collector to Emitter Breakdown Voltage | BV_{CES} | $I_C = 250\mu\text{A}$, $V_{GE} = 0\text{V}$ | 600 | - | - | V | |
| Emitter to Collector Breakdown Voltage | BV_{ECS} | $I_C = 3\text{mA}$, $V_{GE} = 0\text{V}$ | 16 | 30 | - | V | |
| Collector to Emitter Leakage Current | I_{CES} | $V_{CE} = BV_{CES}$ | $T_C = 25^\circ\text{C}$ | - | - | 250 | μA |
| | | | $T_C = 150^\circ\text{C}$ | - | - | 2.0 | mA |
| Collector to Emitter Saturation Voltage | $V_{CE(SAT)}$ | $I_C = I_{C110}$, $V_{GE} = 15\text{V}$ | $T_C = 25^\circ\text{C}$ | - | 1.65 | 2.0 | V |
| | | | $T_C = 150^\circ\text{C}$ | - | 1.85 | 2.2 | V |
| Gate to Emitter Threshold Voltage | $V_{GE(TH)}$ | $I_C = 250\mu\text{A}$, $V_{CE} = V_{GE}$ | $T_C = 25^\circ\text{C}$ | 3.0 | 5.5 | 6.0 | V |
| Gate to Emitter Leakage Current | I_{GES} | $V_{GE} = \pm 25\text{V}$ | - | - | ± 250 | nA | |
| Switching SOA | SSOA | $T_J = 150^\circ\text{C}$ $R_G = 82\Omega$ $V_{GE} = 15\text{V}$ $L = 1\text{mH}$ | $V_{CE(PK)} = 480\text{V}$ | 18 | - | - | A |
| | | | $V_{CE(PK)} = 600\text{V}$ | 2 | - | - | A |
| Gate to Emitter Plateau Voltage | V_{GEP} | $I_C = I_{C110}$, $V_{CE} = 0.5 BV_{CES}$ | - | 8.3 | - | V | |
| On-State Gate Charge | $Q_{g(ON)}$ | $I_C = I_{C110}$, $V_{CE} = 0.5 BV_{CES}$ | $V_{GE} = 15\text{V}$ | - | 10.8 | 13.5 | nC |
| | | | $V_{GE} = 20\text{V}$ | - | 13.8 | 17.3 | nC |
| Current Turn-On Delay Time | $t_{d(ON)I}$ | $T_J = 150^\circ\text{C}$ $I_{CE} = I_{C110}$ $V_{CE(PK)} = 0.8 BV_{CES}$ $V_{GE} = 15\text{V}$ $R_G = 82\Omega$ $L = 1\text{mH}$ | - | 5 | - | ns | |
| Current Rise Time | t_{rI} | | - | 10 | - | ns | |
| Current Turn-Off Delay Time | $t_{d(OFF)I}$ | | - | 325 | 400 | ns | |
| Current Fall Time | t_{fI} | | - | 130 | 275 | ns | |
| Turn-On Energy | E_{ON} | | - | 85 | - | μJ | |
| Turn-Off Energy (Note 3) | E_{OFF} | | - | 245 | - | μJ | |
| Thermal Resistance | $R_{\theta JC}$ | | - | - | - | 3.75 | $^\circ\text{C/W}$ |

NOTE:

3. Turn-Off Energy Loss (E_{OFF}) is defined as the integral of the instantaneous power loss starting at the trailing edge of the input pulse and ending at the point where the collector current equals zero ($I_{CE} = 0\text{A}$). The HGTD3N60C3 and HGTD3N60C3S were tested per JEDEC standard No. 24-1 Method for Measurement of Power Device Turn-Off Switching Loss. This test method produces the true total Turn-Off Energy Loss. Turn-On losses include diode losses.

Typical Performance Curves

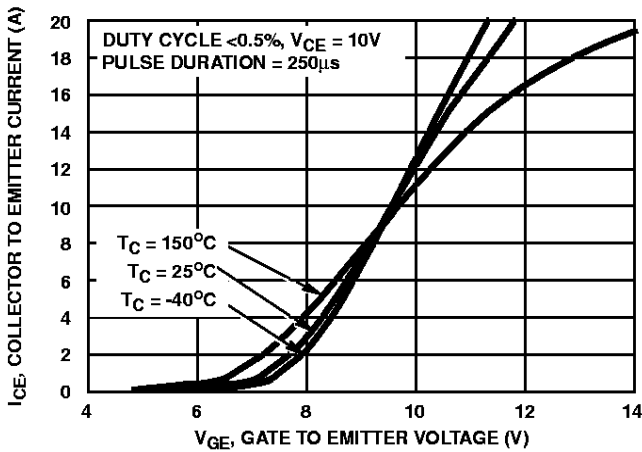

FIGURE 1. TRANSFER CHARACTERISTICS

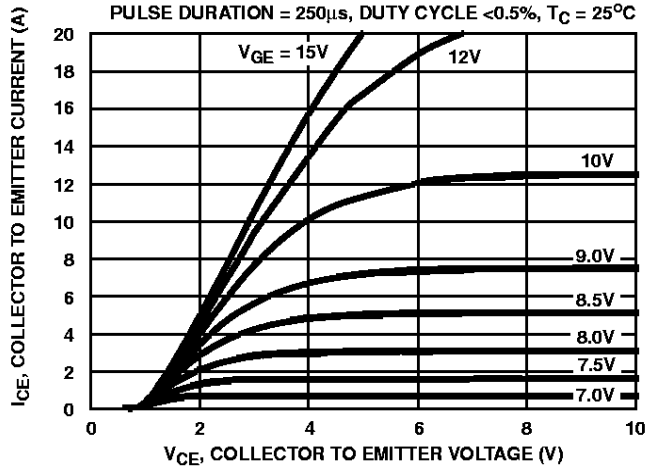

FIGURE 2. SATURATION CHARACTERISTICS

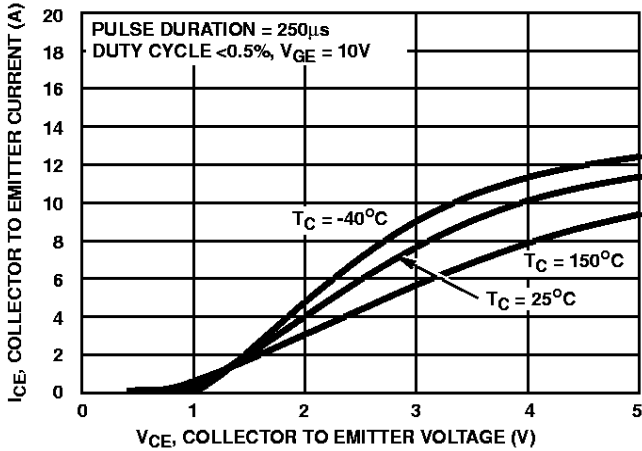

FIGURE 3. COLLECTOR TO EMITTER ON-STATE VOLTAGE

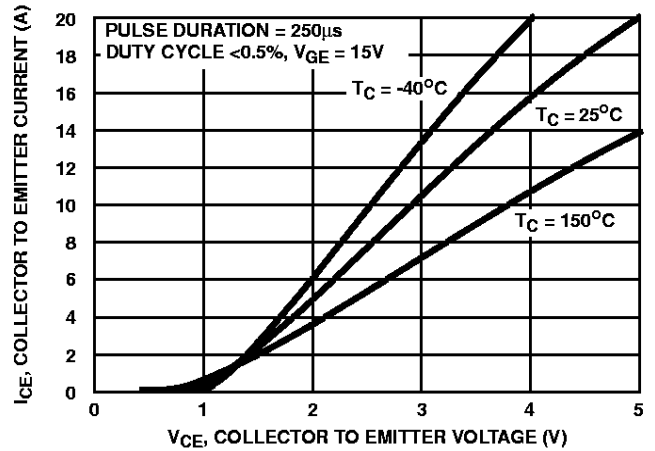

FIGURE 4. COLLECTOR TO EMITTER ON-STATE VOLTAGE

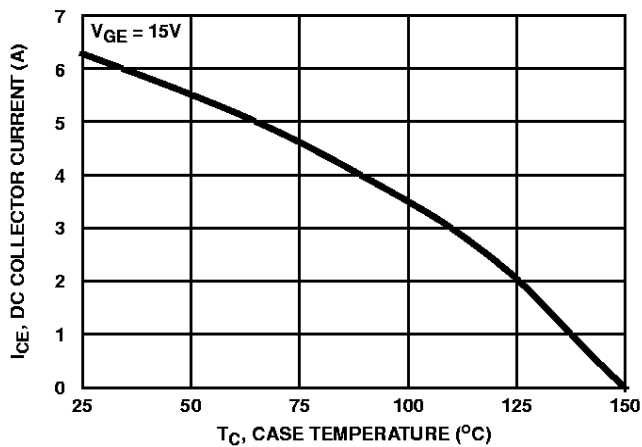

FIGURE 5. MAXIMUM DC COLLECTOR CURRENT AS A FUNCTION OF CASE TEMPERATURE

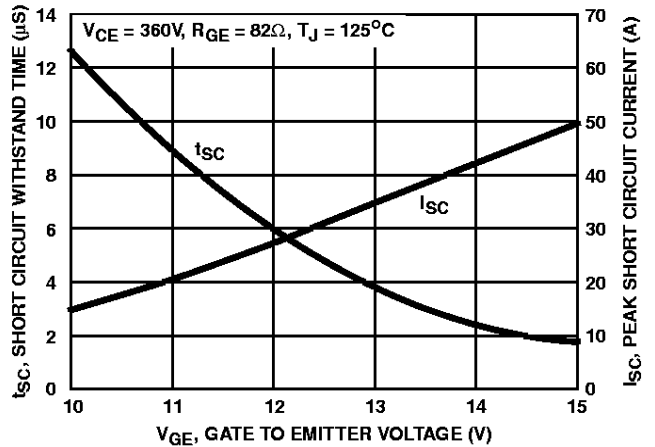

FIGURE 6. SHORT CIRCUIT WITHSTAND TIME

Typical Performance Curves (Continued)

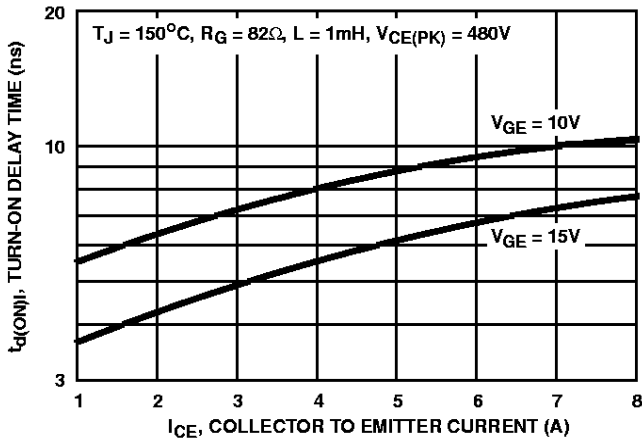

FIGURE 7. TURN-ON DELAY TIME AS A FUNCTION OF COLLECTOR TO EMITTER CURRENT

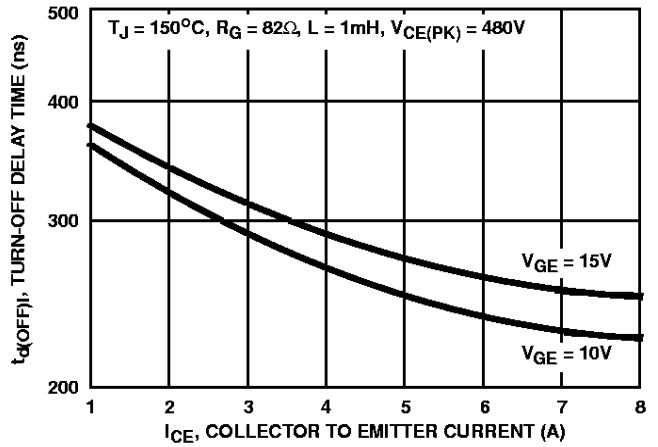

FIGURE 8. TURN-OFF DELAY TIME AS A FUNCTION OF COLLECTOR TO EMITTER CURRENT

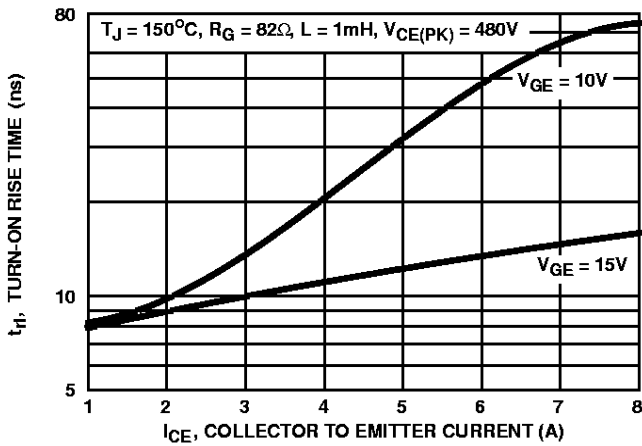

FIGURE 9. TURN-ON RISE TIME AS A FUNCTION OF COLLECTOR TO EMITTER CURRENT

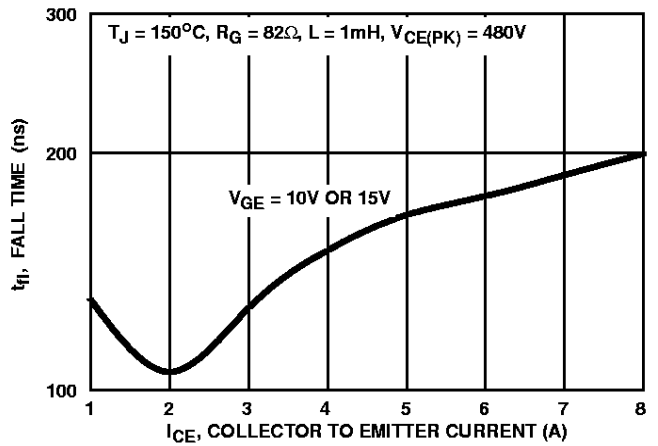

FIGURE 10. TURN-OFF FALL TIME AS A FUNCTION OF COLLECTOR TO EMITTER CURRENT

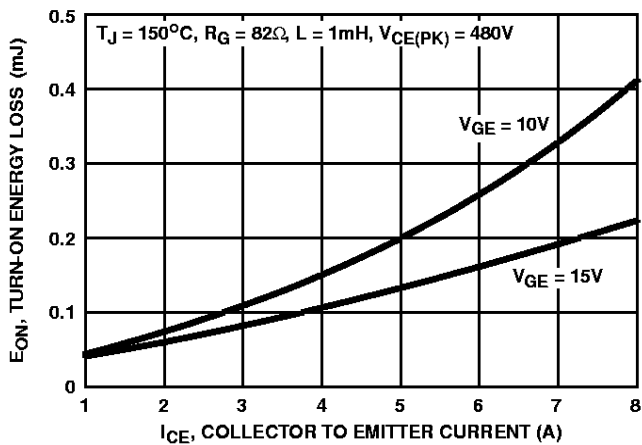

FIGURE 11. TURN-ON ENERGY LOSS AS A FUNCTION OF COLLECTOR TO EMITTER CURRENT

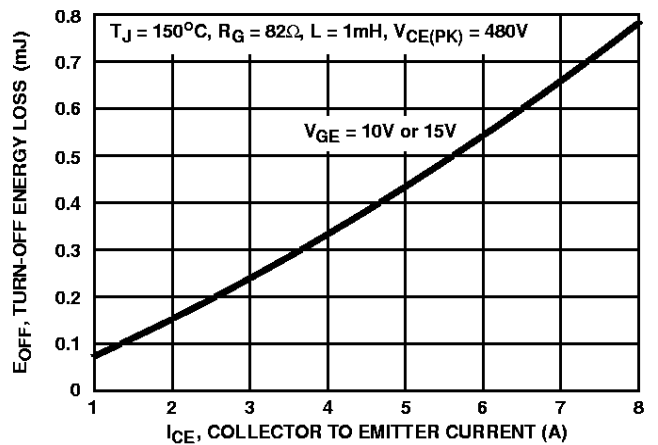

FIGURE 12. TURN-OFF ENERGY LOSS AS A FUNCTION OF COLLECTOR TO EMITTER CURRENT

Typical Performance Curves (Continued)

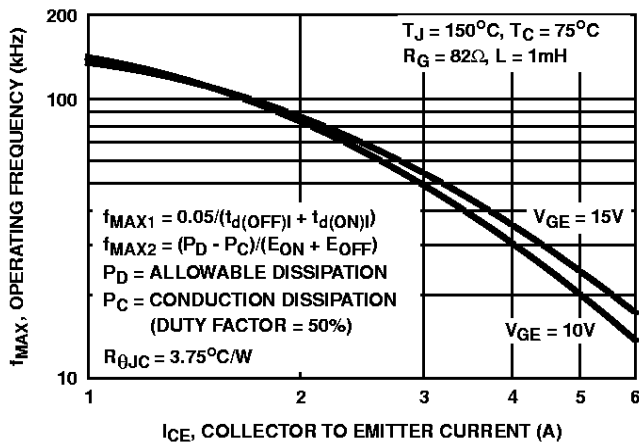

FIGURE 13. OPERATING FREQUENCY AS A FUNCTION OF COLLECTOR TO EMITTER CURRENT

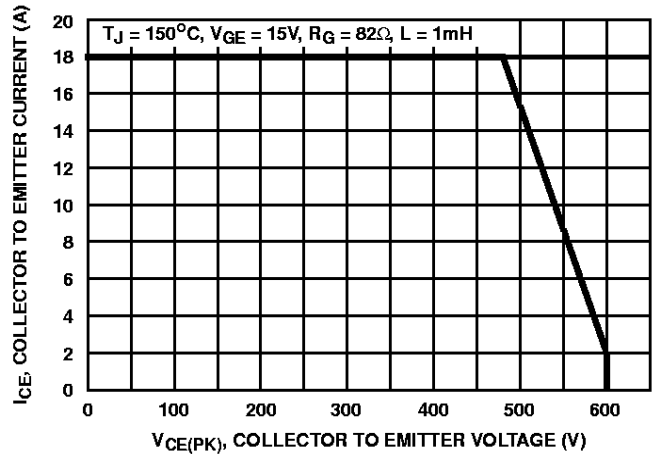

FIGURE 14. MINIMUM SWITCHING SAFE OPERATING AREA

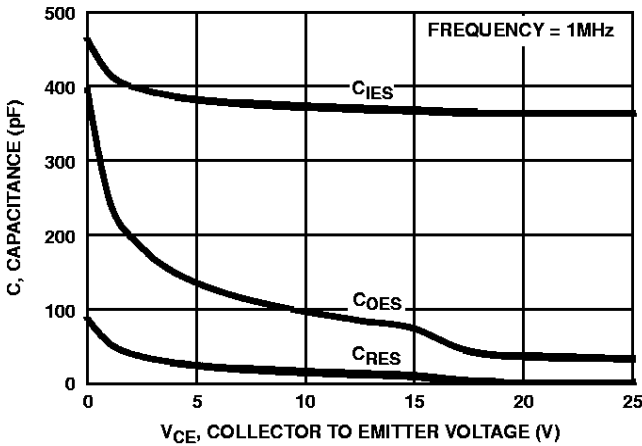

FIGURE 15. CAPACITANCE AS A FUNCTION OF COLLECTOR TO EMITTER VOLTAGE

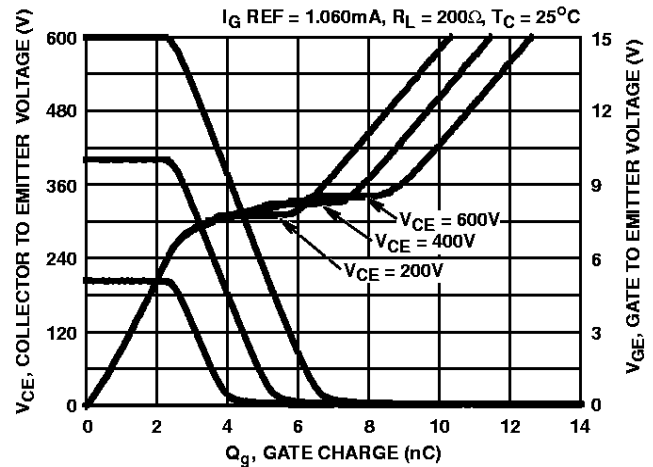

FIGURE 16. GATE CHARGE WAVEFORMS

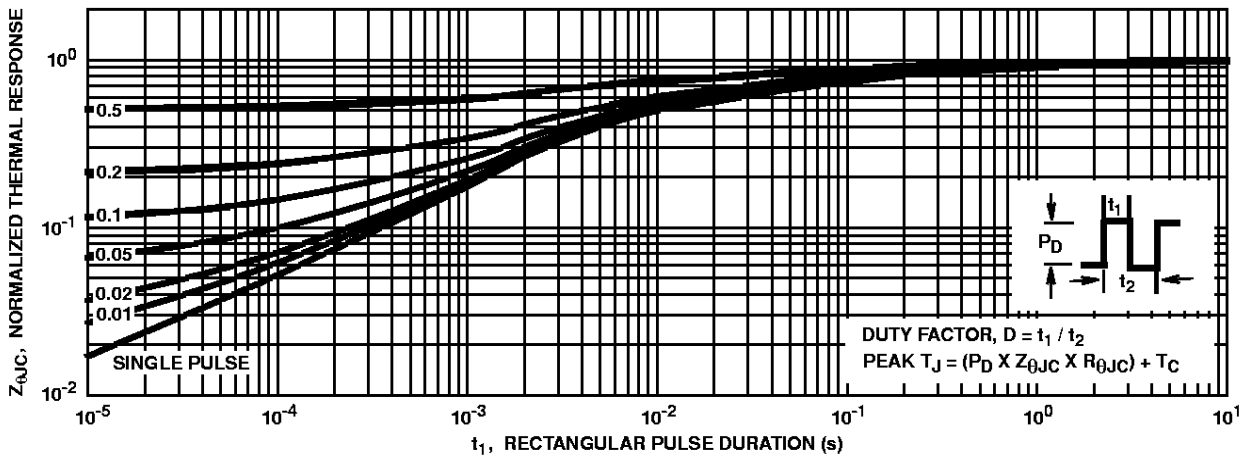

FIGURE 17. IGBT NORMALIZED TRANSIENT THERMAL IMPEDANCE, JUNCTION TO CASE

Test Circuit and Waveform

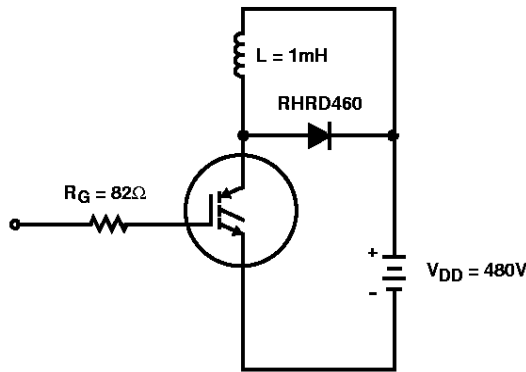

FIGURE 18. INDUCTIVE SWITCHING TEST CIRCUIT

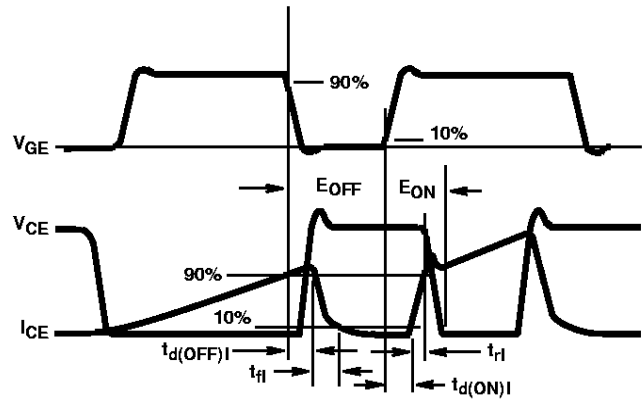

FIGURE 19. SWITCHING TEST WAVEFORMS

Handling Precautions for IGBTs

Insulated Gate Bipolar Transistors are susceptible to gate-insulation damage by the electrostatic discharge of energy through the devices. When handling these devices, care should be exercised to assure that the static charge built in the handler's body capacitance is not discharged through the device. With proper handling and application procedures, however, IGBT's are currently being extensively used in production by numerous equipment manufacturers in military, industrial and consumer applications, with virtually no damage problems due to electrostatic discharge. IGBT's can be handled safely if the following basic precautions are taken:

1. Prior to assembly into a circuit, all leads should be kept shorted together either by the use of metal shorting springs or by the insertion into conductive material such as "ECCOSORBD™ LD26" or equivalent.
2. When devices are removed by hand from their carriers, the hand being used should be grounded by any suitable means - for example, with a metallic wristband.
3. Tips of soldering irons should be grounded.
4. Devices should never be inserted into or removed from circuits with power on.
5. **Gate Voltage Rating** - Never exceed the gate-voltage rating of V_{GEM} . Exceeding the rated V_{GE} can result in permanent damage to the oxide layer in the gate region.
6. **Gate Termination** - The gates of these devices are essentially capacitors. Circuits that leave the gate open-circuited or floating should be avoided. These conditions can result in turn-on of the device due to voltage buildup on the input capacitor due to leakage currents or pickup.
7. **Gate Protection** - These devices do not have an internal monolithic zener diode from gate to emitter. If gate protection is required an external zener is recommended.

ECCOSORBD™ is a Trademark of Emerson and Cumming, Inc.

Operating Frequency Information

Operating Frequency Information for a Typical Device (Figure 13) is presented as a guide for estimating device performance for a specific application. Other typical frequency vs collector current (I_{CE}) plots are possible using the information shown for a typical unit in Figures 4, 7, 8, 11 and 12. The operating frequency plot (Figure 13) of a typical device shows f_{MAX1} or f_{MAX2} whichever is smaller at each point. The information is based on measurements of a typical device and is bounded by the maximum rated junction temperature.

f_{MAX1} is defined by $f_{MAX1} = 0.05 / (t_{d(OFF)I} + t_{d(ON)I})$. Dead-time (the denominator) has been arbitrarily held to 10% of the on-state time for a 50% duty factor. Other definitions are possible. $t_{d(OFF)I}$ and $t_{d(ON)I}$ are defined in Figure 19.

Device turn-off delay can establish an additional frequency limiting condition for an application other than T_{JMAX} . $t_{d(OFF)I}$ is important when controlling output ripple under a lightly loaded condition.

f_{MAX2} is defined by $f_{MAX2} = (P_D - P_C) / (E_{OFF} + E_{ON})$. The allowable dissipation (P_D) is defined by $P_D = (T_{JMAX} - T_C) / R_{\theta JC}$. The sum of device switching and conduction losses must not exceed P_D . A 50% duty factor was used (Figure 13) and the conduction losses (P_C) are approximated by $P_C = (V_{CE} \times I_{CE}) / 2$.

E_{ON} and E_{OFF} are defined in the switching waveforms shown in Figure 19. E_{ON} is the integral of the instantaneous power loss ($I_{CE} \times V_{CE}$) during turn-on and E_{OFF} is the integral of the instantaneous power loss ($I_{CE} \times V_{CE}$) during turn-off. All tail losses are included in the calculation for E_{OFF} ; i.e. the collector current equals zero ($I_{CE} = 0$).

HGTD3N60C3, HGTD3N60C3S

TO-251AA

3 LEAD JEDEC TO-251AA PLASTIC PACKAGE

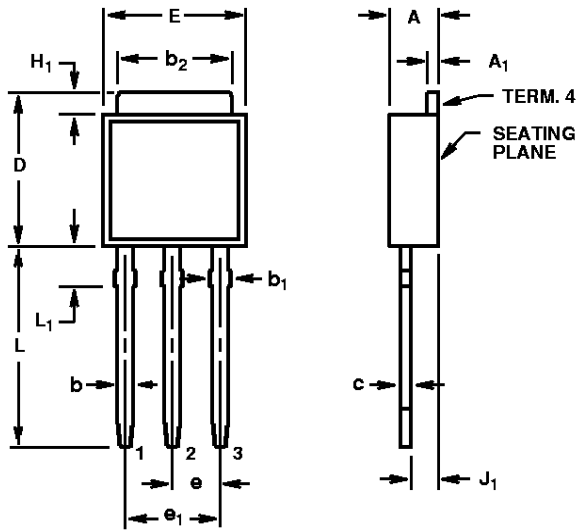

LEAD 1 - GATE
 LEAD 2 - COLLECTOR
 LEAD 3 - EMITTER
 TERM. 4 - COLLECTOR

| SYMBOL | INCHES | | MILLIMETERS | | NOTES |
|----------------|-----------|-------|-------------|------|-------|
| | MIN | MAX | MIN | MAX | |
| A | 0.086 | 0.094 | 2.19 | 2.38 | - |
| A ₁ | 0.018 | 0.022 | 0.46 | 0.55 | 3, 4 |
| b | 0.028 | 0.032 | 0.72 | 0.81 | 3, 4 |
| b ₁ | 0.033 | 0.040 | 0.84 | 1.01 | 3 |
| b ₂ | 0.205 | 0.215 | 5.21 | 5.46 | 3, 4 |
| c | 0.018 | 0.022 | 0.46 | 0.55 | 3, 4 |
| D | 0.270 | 0.290 | 6.86 | 7.36 | - |
| E | 0.250 | 0.265 | 6.35 | 6.73 | - |
| e | 0.090 TYP | | 2.28 TYP | | 5 |
| e ₁ | 0.180 BSC | | 4.57 BSC | | 5 |
| H ₁ | 0.035 | 0.045 | 0.89 | 1.14 | - |
| J ₁ | 0.040 | 0.045 | 1.02 | 1.14 | 6 |
| L | 0.355 | 0.375 | 9.02 | 9.52 | - |
| L ₁ | 0.075 | 0.090 | 1.91 | 2.28 | 2 |

NOTES:

1. These dimensions are within allowable dimensions of Rev. C of JEDEC TO-251AA outline dated 9-88.
2. Solder finish uncontrolled in this area.
3. Dimension (without solder).
4. Add typically 0.002 inches (0.05mm) for solder plating.
5. Position of lead to be measured 0.250 inches (6.35mm) from bottom of dimension D.
6. Position of lead to be measured 0.100 inches (2.54mm) from bottom of dimension D.
7. Controlling dimension: Inch.
8. Revision 2 dated 10-95.

HGTD3N60C3, HGTD3N60C3S

TO-252AA

SURFACE MOUNT JEDEC TO-252AA PLASTIC PACKAGE

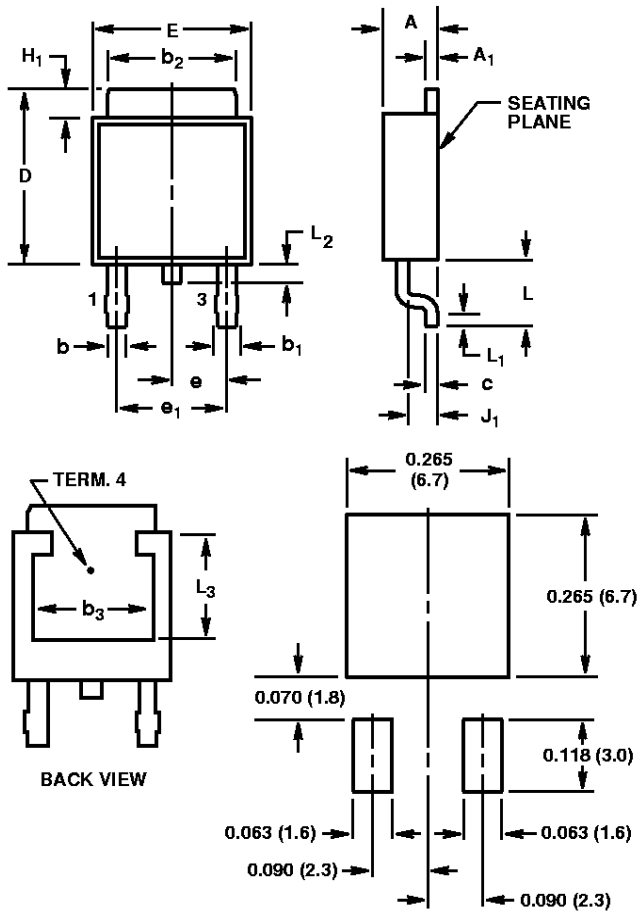

MINIMUM PAD SIZE RECOMMENDED FOR SURFACE-MOUNTED APPLICATIONS

- LEAD 1 - GATE
- LEAD 3 - EMITTER
- TERM. 4 - COLLECTOR

| SYMBOL | INCHES | | MILLIMETERS | | NOTES |
|----------------|-----------|-------|-------------|------|-------|
| | MIN | MAX | MIN | MAX | |
| A | 0.086 | 0.094 | 2.19 | 2.38 | - |
| A ₁ | 0.018 | 0.022 | 0.46 | 0.55 | 4, 5 |
| b | 0.028 | 0.032 | 0.72 | 0.81 | 4, 5 |
| b ₁ | 0.033 | 0.040 | 0.84 | 1.01 | 4 |
| b ₂ | 0.205 | 0.215 | 5.21 | 5.46 | 4, 5 |
| b ₃ | 0.190 | - | 4.83 | - | 2 |
| c | 0.018 | 0.022 | 0.46 | 0.55 | 4, 5 |
| D | 0.270 | 0.290 | 6.86 | 7.36 | - |
| E | 0.250 | 0.265 | 6.35 | 6.73 | - |
| e | 0.090 TYP | | 2.28 TYP | | 7 |
| e ₁ | 0.180 BSC | | 4.57 BSC | | 7 |
| H ₁ | 0.035 | 0.045 | 0.89 | 1.14 | - |
| J ₁ | 0.040 | 0.045 | 1.02 | 1.14 | - |
| L | 0.100 | 0.115 | 2.54 | 2.92 | - |
| L ₁ | 0.020 | - | 0.51 | - | 4, 6 |
| L ₂ | 0.025 | 0.040 | 0.64 | 1.01 | 3 |
| L ₃ | 0.170 | - | 4.32 | - | 2 |

NOTES:

1. These dimensions are within allowable dimensions of Rev. B of JEDEC TO-252AA outline dated 9-88.
2. L₃ and b₃ dimensions establish a minimum mounting surface for terminal 4.
3. Solder finish uncontrolled in this area.
4. Dimension (without solder).
5. Add typically 0.002 inches (0.05mm) for solder plating.
6. L₁ is the terminal length for soldering.
7. Position of lead to be measured 0.090 inches (2.28mm) from bottom of dimension D.
8. Controlling dimension: Inch.
9. Revision 6 dated 10-96.

HGTD3N60C3, HGTD3N60C3S

TO-252AA

16mm TAPE AND REEL

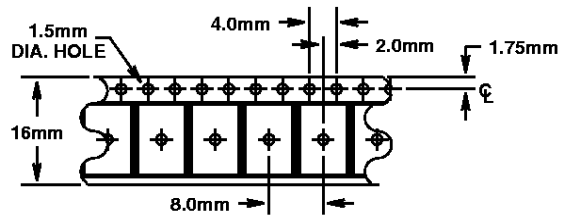
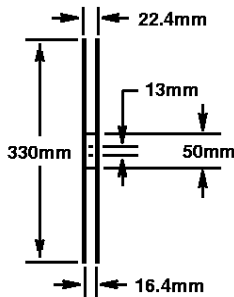
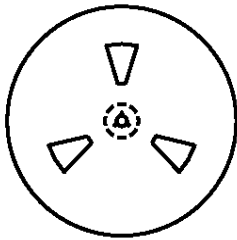

USER DIRECTION OF FEED

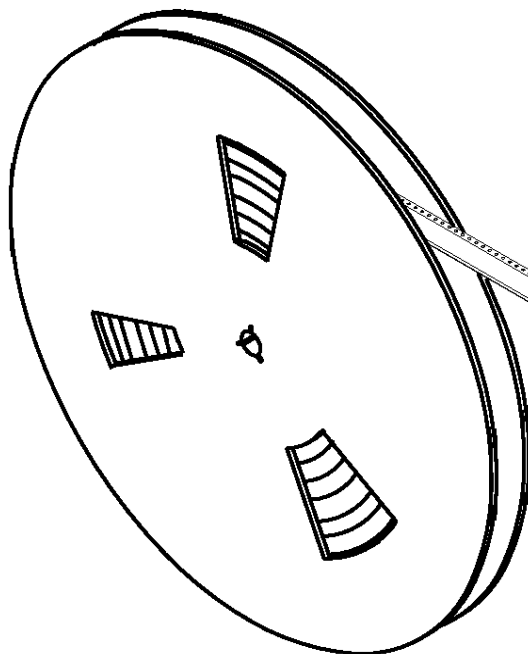
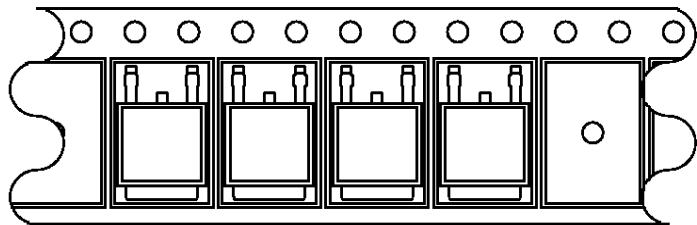

COVER TAPE

GENERAL INFORMATION

1. USE "9A" SUFFIX ON PART NUMBER.
2. 2500 PIECES PER REEL.
3. ORDER IN MULTIPLES OF FULL REELS ONLY.
4. MEETS EIA-481 REVISION "A" SPECIFICATIONS.

Revision 6 dated 10-96

All Harris Semiconductor products are manufactured, assembled and tested under **ISO9000** quality systems certification.

Harris Semiconductor products are sold by description only. Harris Semiconductor reserves the right to make changes in circuit design and/or specifications at any time without notice. Accordingly, the reader is cautioned to verify that data sheets are current before placing orders. Information furnished by Harris is believed to be accurate and reliable. However, no responsibility is assumed by Harris or its subsidiaries for its use; nor for any infringements of patents or other rights of third parties which may result from its use. No license is granted by implication or otherwise under any patent or patent rights of Harris or its subsidiaries.

Sales Office Headquarters

For general information regarding Harris Semiconductor and its products, call **1-800-4-HARRIS**

NORTH AMERICA

Harris Semiconductor
P. O. Box 883, Mail Stop 53-210
Melbourne, FL 32902
TEL: 1-800-442-7747
(407) 729-4984
FAX: (407) 729-5321

EUROPE

Harris Semiconductor
Mercure Center
100, Rue de la Fusee
1130 Brussels, Belgium
TEL: (32) 2.724.2111
FAX: (32) 2.724.22.05

ASIA

Harris Semiconductor PTE Ltd.
No. 1 Tannery Road
Cencon 1, #09-01
Singapore 1334
TEL: (65) 748-4200
FAX: (65) 748-0400

