

To our customers,

---

## Old Company Name in Catalogs and Other Documents

---

On April 1<sup>st</sup>, 2010, NEC Electronics Corporation merged with Renesas Technology Corporation, and Renesas Electronics Corporation took over all the business of both companies. Therefore, although the old company name remains in this document, it is a valid Renesas Electronics document. We appreciate your understanding.

Renesas Electronics website: <http://www.renesas.com>

April 1<sup>st</sup>, 2010  
Renesas Electronics Corporation

Issued by: Renesas Electronics Corporation (<http://www.renesas.com>)

Send any inquiries to <http://www.renesas.com/inquiry>.

Not recommended  
for new design

## Notice

1. All information included in this document is current as of the date this document is issued. Such information, however, is subject to change without any prior notice. Before purchasing or using any Renesas Electronics products listed herein, please confirm the latest product information with a Renesas Electronics sales office. Also, please pay regular and careful attention to additional and different information to be disclosed by Renesas Electronics such as that disclosed through our website.
2. Renesas Electronics does not assume any liability for infringement of patents, copyrights, or other intellectual property rights of third parties by or arising from the use of Renesas Electronics products or technical information described in this document. No license, express, implied or otherwise, is granted hereby under any patents, copyrights or other intellectual property rights of Renesas Electronics or others.
3. You should not alter, modify, copy, or otherwise misappropriate any Renesas Electronics product, whether in whole or in part.
4. Descriptions of circuits, software and other related information in this document are provided only to illustrate the operation of semiconductor products and application examples. You are fully responsible for the incorporation of these circuits, software, and information in the design of your equipment. Renesas Electronics assumes no responsibility for any losses incurred by you or third parties arising from the use of these circuits, software, or information.
5. When exporting the products or technology described in this document, you should comply with the applicable export control laws and regulations and follow the procedures required by such laws and regulations. You should not use Renesas Electronics products or the technology described in this document for any purpose relating to military applications or use by the military, including but not limited to the development of weapons of mass destruction. Renesas Electronics products and technology may not be used for or incorporated into any products or systems whose manufacture, use, or sale is prohibited under any applicable domestic or foreign laws or regulations.
6. Renesas Electronics has used reasonable care in preparing the information included in this document, but Renesas Electronics does not warrant that such information is error free. Renesas Electronics assumes no liability whatsoever for any damages incurred by you resulting from errors in or omissions from the information included herein.
7. Renesas Electronics products are classified according to the following three quality grades: “Standard”, “High Quality”, and “Specific”. The recommended applications for each Renesas Electronics product depends on the product’s quality grade, as indicated below. You must check the quality grade of each Renesas Electronics product before using it in a particular application. You may not use any Renesas Electronics product for any application categorized as “Specific” without the prior written consent of Renesas Electronics. Further, you may not use any Renesas Electronics product for any application for which it is not intended without the prior written consent of Renesas Electronics. Renesas Electronics shall not be in any way liable for any damages or losses incurred by you or third parties arising from the use of any Renesas Electronics product for an application categorized as “Specific” or for which the product is not intended where you have failed to obtain the prior written consent of Renesas Electronics. The quality grade of each Renesas Electronics product is “Standard” unless otherwise expressly specified in a Renesas Electronics data sheets or data books, etc.
  - “Standard”: Computers; office equipment; communications equipment; test and measurement equipment; audio and visual equipment; home electronic appliances; machine tools; personal electronic equipment; and industrial robots.
  - “High Quality”: Transportation equipment (automobiles, trains, ships, etc.); traffic control systems; anti-disaster systems; anti-crime systems; safety equipment; and medical equipment not specifically designed for life support.
  - “Specific”: Aircraft; aerospace equipment; submersible repeaters; nuclear reactor control systems; medical equipment or systems for life support (e.g. artificial life support devices or systems), surgical implantations, or healthcare intervention (e.g. excision, etc.), and any other applications or purposes that pose a direct threat to human life.
8. You should use the Renesas Electronics products described in this document within the range specified by Renesas Electronics, especially with respect to the maximum rating, operating supply voltage range, movement power voltage range, heat radiation characteristics, installation and other product characteristics. Renesas Electronics shall have no liability for malfunctions or damages arising out of the use of Renesas Electronics products beyond such specified ranges.
9. Although Renesas Electronics endeavors to improve the quality and reliability of its products, semiconductor products have specific characteristics such as the occurrence of failure at a certain rate and malfunctions under certain use conditions. Further, Renesas Electronics products are not subject to radiation resistance design. Please be sure to implement safety measures to guard them against the possibility of physical injury, and injury or damage caused by fire in the event of the failure of a Renesas Electronics product, such as safety design for hardware and software including but not limited to redundancy, fire control and malfunction prevention, appropriate treatment for aging degradation or any other appropriate measures. Because the evaluation of microcomputer software alone is very difficult, please evaluate the safety of the final products or system manufactured by you.
10. Please contact a Renesas Electronics sales office for details as to environmental matters such as the environmental compatibility of each Renesas Electronics product. Please use Renesas Electronics products in compliance with all applicable laws and regulations that regulate the inclusion or use of controlled substances, including without limitation, the EU RoHS Directive. Renesas Electronics assumes no liability for damages or losses occurring as a result of your noncompliance with applicable laws and regulations.
11. This document may not be reproduced or duplicated, in any form, in whole or in part, without prior written consent of Renesas Electronics.
12. Please contact a Renesas Electronics sales office if you have any questions regarding the information contained in this document or Renesas Electronics products, or if you have any other inquiries.

(Note 1) “Renesas Electronics” as used in this document means Renesas Electronics Corporation and also includes its majority-owned subsidiaries.

(Note 2) “Renesas Electronics product(s)” means any product developed or manufactured by or for Renesas Electronics.

---

# HA16116FP/FPJ, HA16121FP/FPJ

## Switching Regulator for Chopper Type DC/DC Converter

REJ03F0056-0200Z  
(Previous: ADE-204-019A)  
Rev.2.0  
Sep.18.2003

---

### Description

HA16116FP/FPJ and HA16121FP/FPJ are dual-channel PWM switching regulator controller ICs for use in chopper-type DC/DC converters.

This IC series incorporates totem pole gate drive circuits to allow direct driving of a power MOS FET. The output logic is preset for booster, step-down, or inverting control in a DC/DC converter. This logic assumes use of an N-channel power MOS FET for booster control, and a P-channel power MOS FET for step-down or inverting control.

HA16116 includes a built-in logic circuit for step-down control only, and one for use in both step-down and inverting control. HA16121 has a logic circuit for booster control only and one for both step-down and inverting control.

Both ICs have a pulse-by-pulse current limiter, which limits PWM pulse width per pulse as a means of protecting against overcurrent, and which uses an on/off timer for intermittent operation. Unlike conventional methods that use a latch timer for shutdown, when the pulse-by-pulse current limiter continues operation beyond the time set in the timer, the IC is made to operate intermittently (flickering operation), resulting in sharp vertical setting characteristics. When the overcurrent condition subsides, the output is automatically restored to normal.

The dual control circuits in the IC output identical triangle waveforms, for completely synchronous configuring a compact, high efficiency dual-channel DC/DC converter, with fewer external components than were necessary previously.

### Functions

- 2.5 V reference voltage (Vref) regulator
- Triangle wave form oscillator
- Dual overcurrent detector
- Dual totem pole output driver
- UVL (under voltage lock out) system
- Dual error amplifier
- Vref overvoltage detector
- Dual PWM comparator

## HA16116FP/FPJ, HA16121FP/FPJ

### Features

- Wide operating supply voltage range\* (3.9 V to 40.0 V)
- Wide operating frequency range (600 kHz maximum operation)
- Direct power MOS FET driving (output current  $\pm 1$  A peak in maximum rating)
- Pulse-by-pulse overcurrent protection circuit with intermittent operation function (When overcurrent state continues beyond time set in timer, the IC operates intermittently to prevent excessive output current.)
- Grounding the ON/OFF pin turns the IC off, saving power dissipation. (HA16116:  $I_{OFF} = 10 \mu\text{A max.}$ ; HA16121:  $I_{OFF} = 150 \mu\text{A max.}$ )
- Built-in UVL circuit (UVL voltage can be varied with external resistance.)
- Built-in soft start and quick shutoff functions

Note: The reference voltage 2.5 V is under the condition of  $V_{IN} \geq 4.5$  V.

### Ordering Information

#### Hitachi Control ICs for Chopper-Type DC/DC Converters

Channels	Product Number	Channel No.	Control Functions			Output Circuits	Overcurrent Protection
			Step-Up	Step-Down	Inverting		
Dual	HA17451	Ch 1	○	○	○	Open collector	SCP with timer (latch)
		Ch 2	○	○	○		
Single	HA16114	—	—	○	○	Totem pole power MOS FET driver	Pulse-by-pulse current limiter and intermittent operation by on/off timer
	HA16120	—	○	—	—		
Dual	HA16116	Ch 1	—	○	○		
		Ch 2	—	○	—		
	HA16121	Ch 1	—	○	○		
		Ch 2	○	—	—		

Pin Arrangement

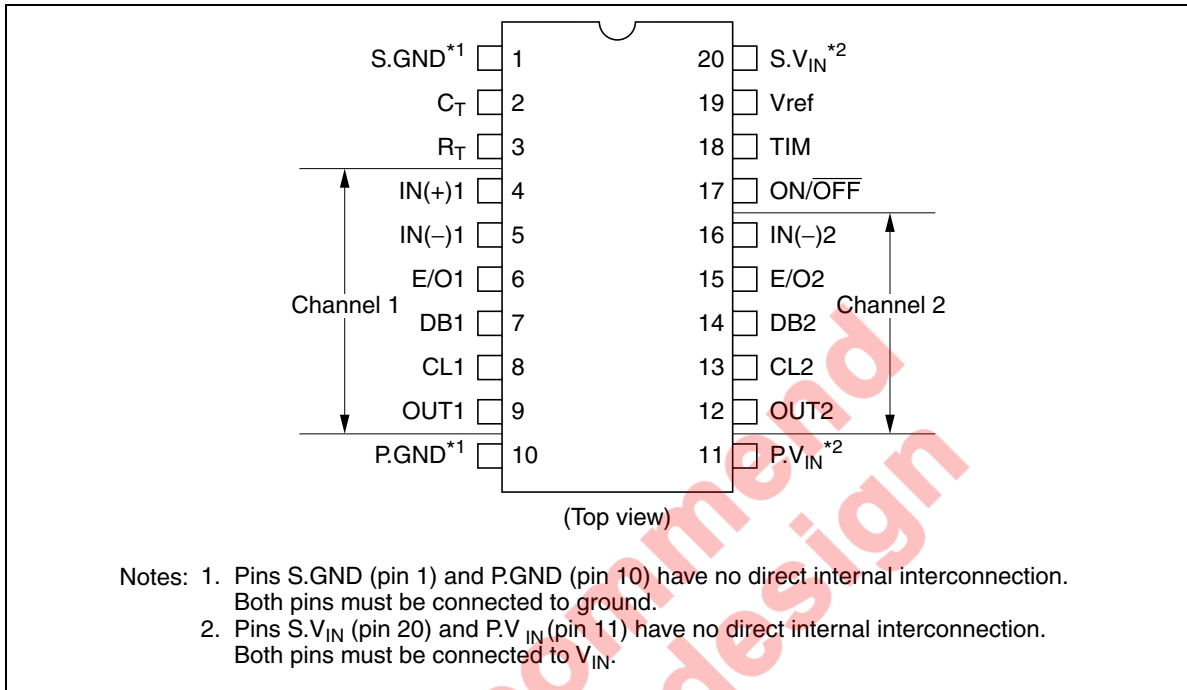

## Pin Functions

Pin No.	Symbol	Function	
1	S.GND	Signal circuitry* <sup>1</sup> ground	
2	C <sub>T</sub>	Timing capacitance (triangle wave oscillator output)	
3	R <sub>T</sub>	Timing resistance (for bias current synchronization)	
4	IN(+) <sub>1</sub>	Error amp. noninverting input (1)	Channel 1
5	IN(-) <sub>1</sub>	Error amp. inverting input (1)	
6	E/O <sub>1</sub>	Error amp. output (1)	
7	DB <sub>1</sub>	Dead band timer off period adjustment input (1)	
8	CL <sub>1</sub>	Overcurrent detection input (1)	
9	OUT <sub>1</sub>	PWM pulse output (1)	
10	P.GND	Output stage* <sup>1</sup> ground	
11	P.V <sub>IN</sub>	Output stage* <sup>1</sup> power supply input	
12	OUT <sub>2</sub>	PWM pulse output (2)	Channel 2
13	CL <sub>2</sub>	Overcurrent detection input (2)	
14	DB <sub>2</sub>	Dead band timer off period adjustment input (2)	
15	E/O <sub>2</sub>	Error amp. output (2)	
16	IN(-) <sub>2</sub>	Error amp. inverting input (2)* <sup>2</sup>	
17	ON/OFF	IC on/off switch input (off when grounded)	
18	TIM	Setting of intermittent operation timing when overcurrent is detected (collector input of timer transistor)	
19	Vref	2.5 V reference voltage output	
20	S.V <sub>IN</sub>	Signal circuitry* <sup>1</sup> power supply input	

- Notes: 1. Here "output stage" refers to the power MOS FET driver circuits, and "signal circuitry" refers to all other circuits on the IC. Note that this IC is not protected against reverse insertion, which can cause breakdown of the IC between V<sub>IN</sub> and GND. Be careful to insert the IC correctly.
2. Noninverting input of the channel 2 error amp is connected internally to Vref.

Block Diagram

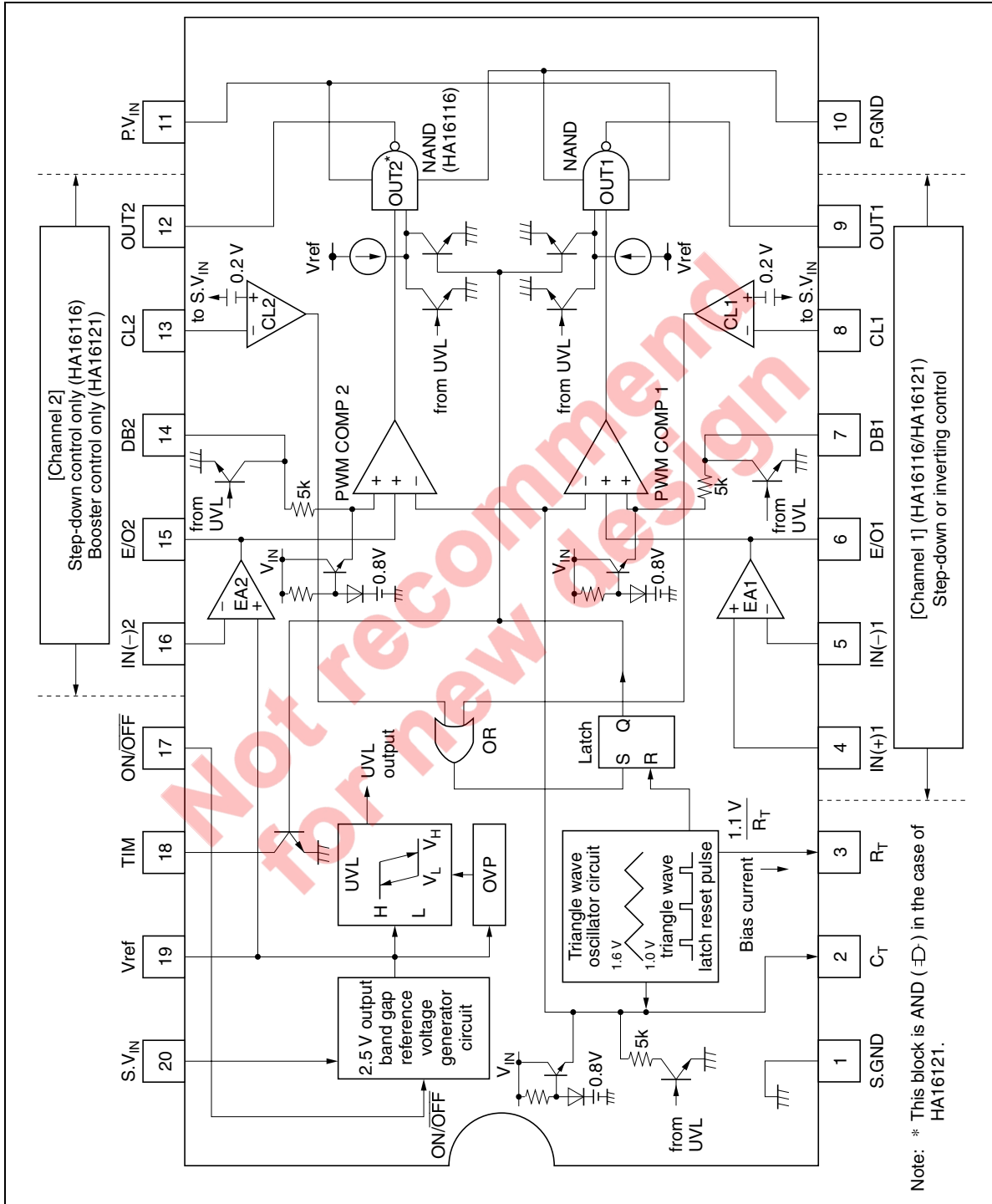

Function and Timing Chart

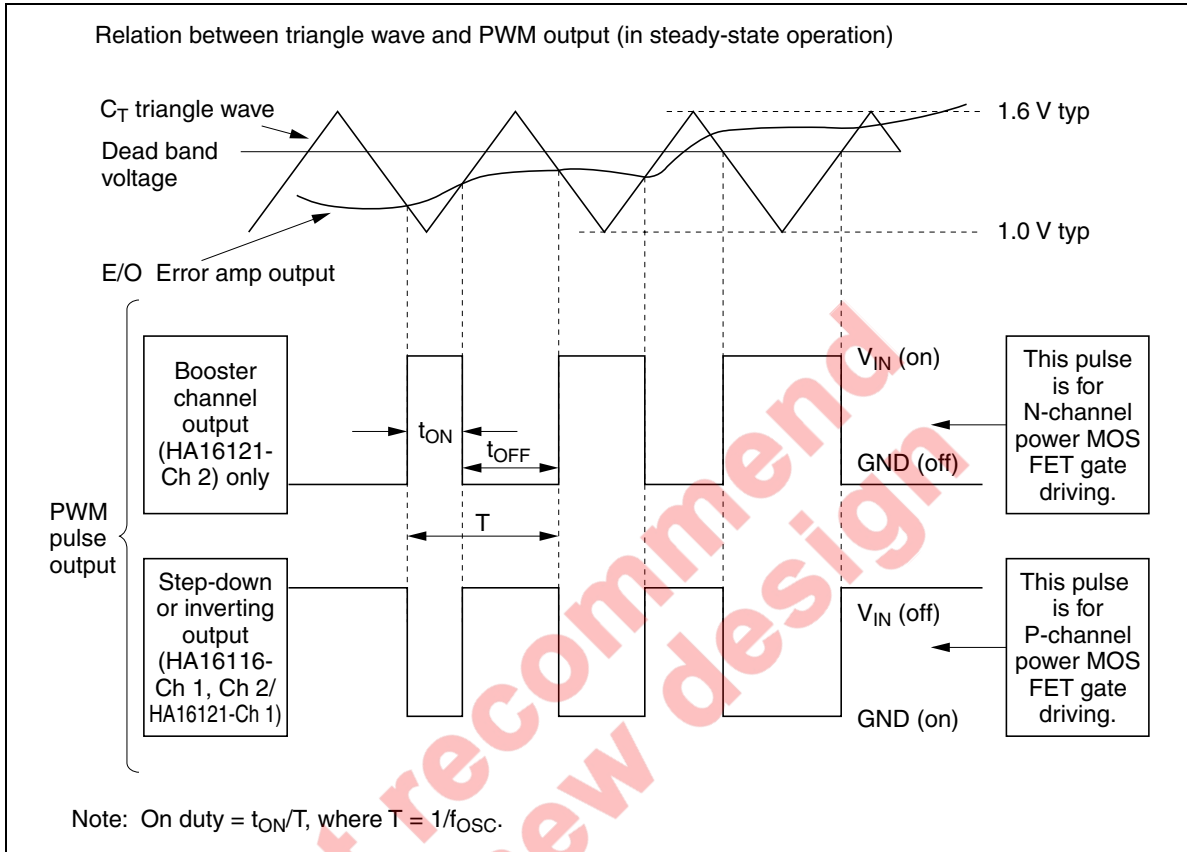



## Determining External Component Constants (pin usage)

Constant settings are explained for the following items.

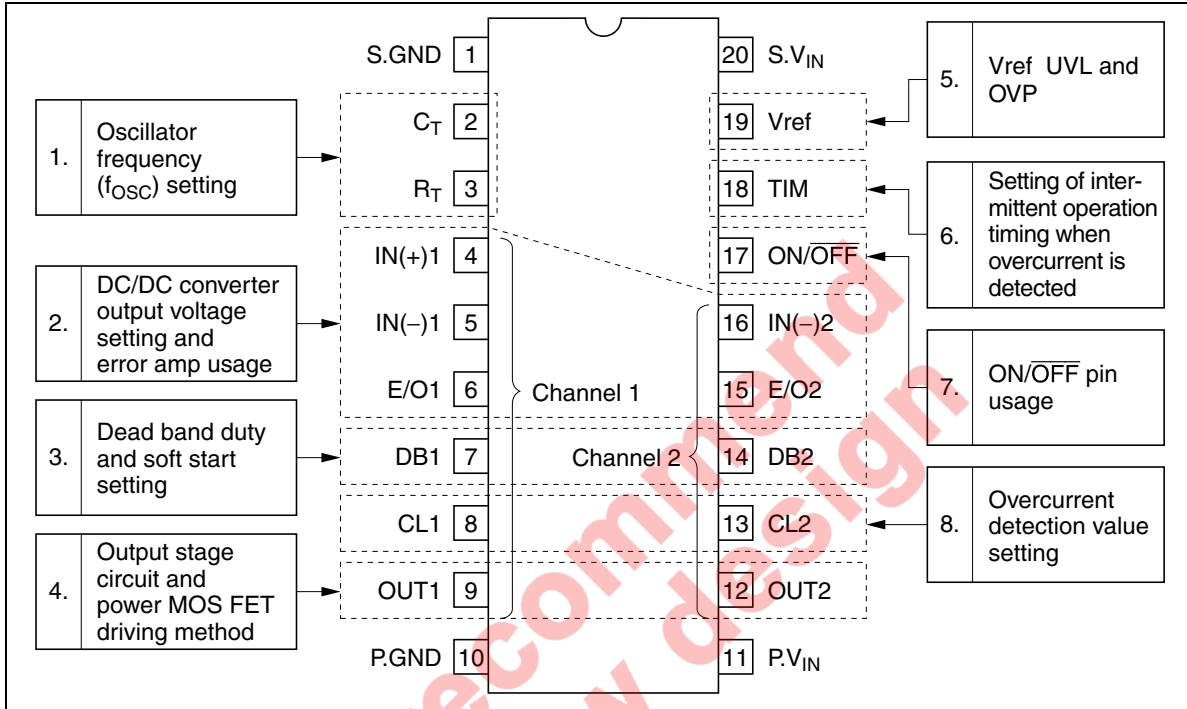

### 1. Oscillator Frequency ( $f_{osc}$ ) Setting

Figure 1.1 shows an equivalent circuit for the triangle wave oscillator.

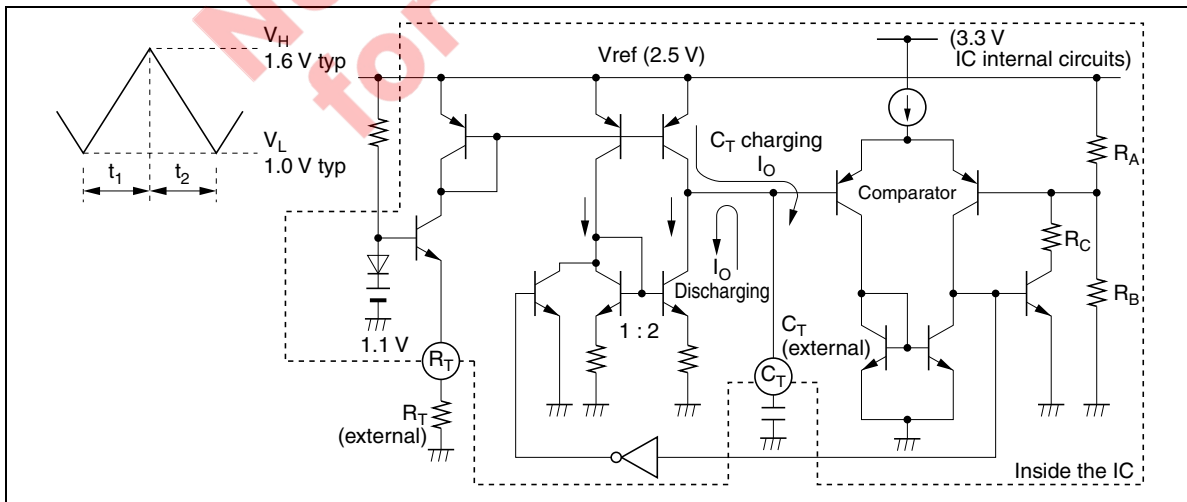

Figure 1.1 Equivalent Circuit for the Triangle Wave Oscillator

## HA16116FP/FPJ, HA16121FP/FPJ

---

The triangle wave is a voltage waveform used as a reference in creating a PWM pulse. This block operates according to the following principles. A constant current  $I_o$ , determined by an external timing resistor  $R_T$ , is made to flow continuously to external timing capacitor  $C_T$ . When the  $C_T$  pin voltage exceeds the comparator threshold voltage  $V_H$ , the comparator output causes a switch to operate, discharging a current  $I_o$  from  $C_T$ . Next, when the  $C_T$  pin voltage drops below threshold voltage  $V_L$ , the comparator output again causes the switch to operate, stopping the  $I_o$  discharge. The triangle wave is generated by this repeated operation.

Note that  $I_o = 1.1 \text{ V}/R_T$ . Since the  $I_o$  current mirror circuit has a very limited current producing ability,  $R_T$  should be set to  $\geq 5 \text{ k}\Omega$  ( $I_o \geq 220 \text{ }\mu\text{A}$ ).

With this IC series,  $V_H$  and  $V_L$  of the triangle wave are fixed internally at about 1.6 V and 1.0 V by the internal resistors  $R_A$ ,  $R_B$ , and  $R_C$ . The oscillator frequency can be calculated as follows.

$$f_{\text{OSC}} = \frac{1}{t_1 + t_2 + t_3}$$

Here,

$$t_1 = \frac{C_T \cdot (V_H - V_L)}{1.1 \text{ V}/R_T} = \frac{C_T R_T \cdot (V_H - V_L)}{1.1 \text{ V}}$$

$$t_2 = \frac{C_T \cdot (V_H - V_L)}{(2 - 1) \times 1.1 \text{ V}/R_T} = \frac{C_T R_T \cdot (V_H - V_L)}{1.1 \text{ V}} = t_1$$

$$V_H - V_L = 0.6 \text{ V}$$

$$t_1 = t_2 = \frac{0.6}{1.1} C_T R_T$$

$$t_3 \approx 0.8 \text{ }\mu\text{s} \text{ (comparator delay time in the oscillator)}$$

Accordingly,

$$f_{\text{OSC}} \approx \frac{1}{2t_1 + t_3} \approx \frac{1}{1.1 C_T R_T + 0.8 \text{ }\mu\text{s}} \text{ [Hz]}$$

Note that the value of  $f_{\text{osc}}$  may differ slightly from the above calculation depending on the amount of delay in the comparator circuit. Also, at high frequencies this comparator delay can cause triangle wave overshoot or undershoot, skewing the dead band threshold. Confirm the actual value in implementation and adjust the constants accordingly.

2. DC/DC Converter Output Voltage Setting and Error Amp Usage

2.1 Positive Voltage Booster ( $V_o > V_{IN}$ ) or Step-Down ( $V_{IN} > V_o > V_{ref}$ )

$$\text{Use } V_o = \frac{R_1 + R_2}{R_2} \cdot V_{ref} \text{ (V)}$$

Booster output is possible only at channel 2 of HA16121. For step-down output, both channels of HA16116 or channel 1 of HA16121 are used.

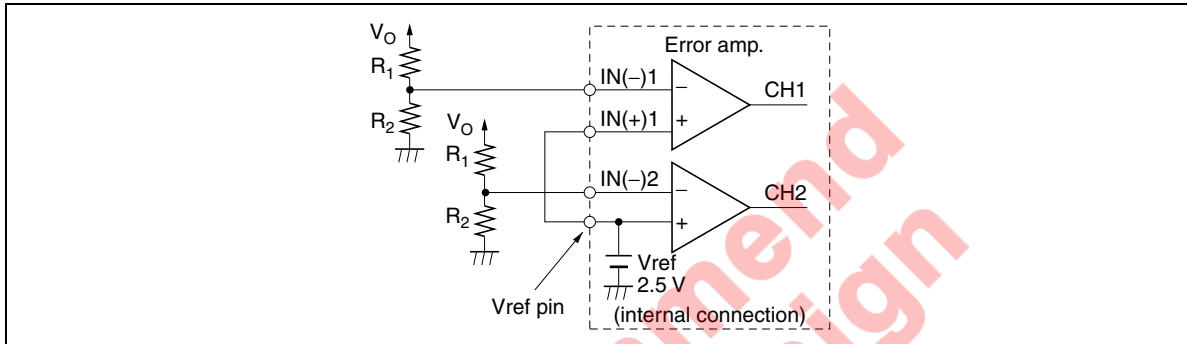

Figure 2.1

2.2 Negative Voltage ( $V_o < V_{ref}$ ) for Inverting Output

$$\text{Use } V_o = -V_{ref} \cdot \left( \frac{R_1}{R_1 + R_2} \cdot \frac{R_3 + R_4}{R_3} - 1 \right) \text{ (V)}$$

Channel 1 is used for inverting output on both ICs.

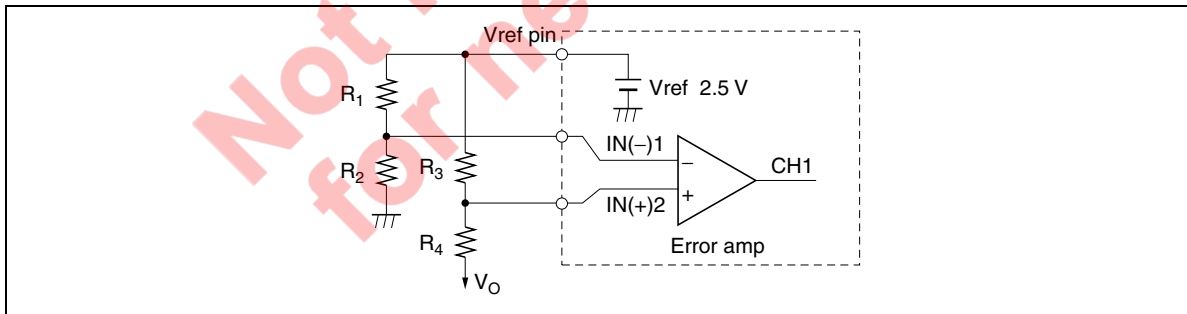

Figure 2.2 Inverting Output

**2.3 Error Amplifier**

Figure 2.3 shows an equivalent circuit of the error amplifier. The error amplifier on these ICs is configured of a simple NPN transistor differential input amplifier and the output circuit of a constant-current driver.

This amplifier features wide bandwidth ( $f_T = 4 \text{ MHz}$ ) with open loop gain kept to 50 dB, allowing stable feedback to be applied when the power supply is designed. Phase compensation is also easy.

Both HA16116 and HA16121 have a noninverting input (IN(+)) pin, in order to allow use of the channel 1 error amplifier for inverting control. The channel 2 error amplifier, on the other hand, is used for step-down control in HA16116 and booster control in HA16121; so the channel 2 noninverting input is connected internally to Vref.

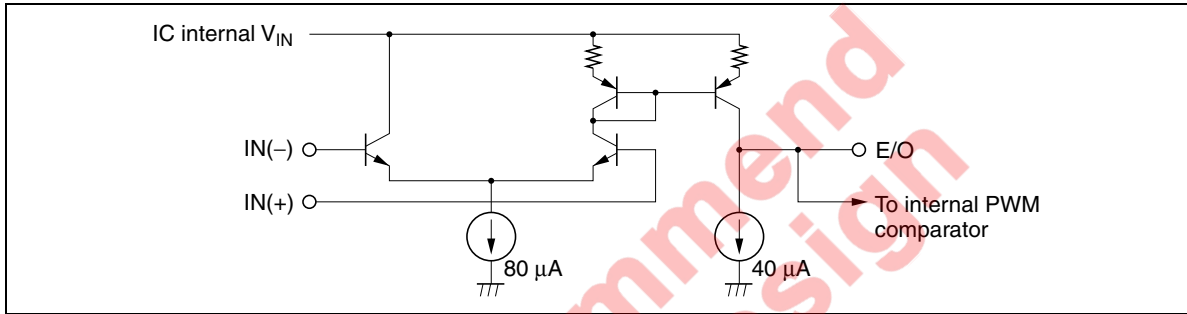

**Figure 2.3 Error Amplifier Equivalent Circuit**

**3. Dead Band (DB) Duty and Soft Start Setting (common to both channels)**

**3.1 Dead Band Duty Setting**

Dead band duty is set by adjusting the DB pin input voltage ( $V_{DB}$ ). A convenient means of doing this is to connect two external resistors to the Vref of this IC so as to divide  $V_{DB}$  (see figure 3.1).

$$V_{DB} = V_{ref} \times \frac{R_2}{R_1 + R_2} \text{ (V)}$$

$$\text{Duty (DB)} = \frac{V_{TH} - V_{DB}}{V_{TH} - V_{TL}} \times 100 \text{ (\%)} \dots \text{ This applies when } V_{DB} > V_{TL}.$$

If  $V_{DB} < V_{TL}$ , there is no PWM output.

$$\text{Here, } T = \frac{1}{f_{OSC}}$$

Note:  $V_{TH}$ : 1.6 V (Typ)

$V_{TL}$ : 1.0 V (Typ)

Vref is typically 2.5 V. Select  $R_1$  and  $R_2$  so that  $1.0 \text{ V} \leq V_{DB} \leq 1.6 \text{ V}$ .

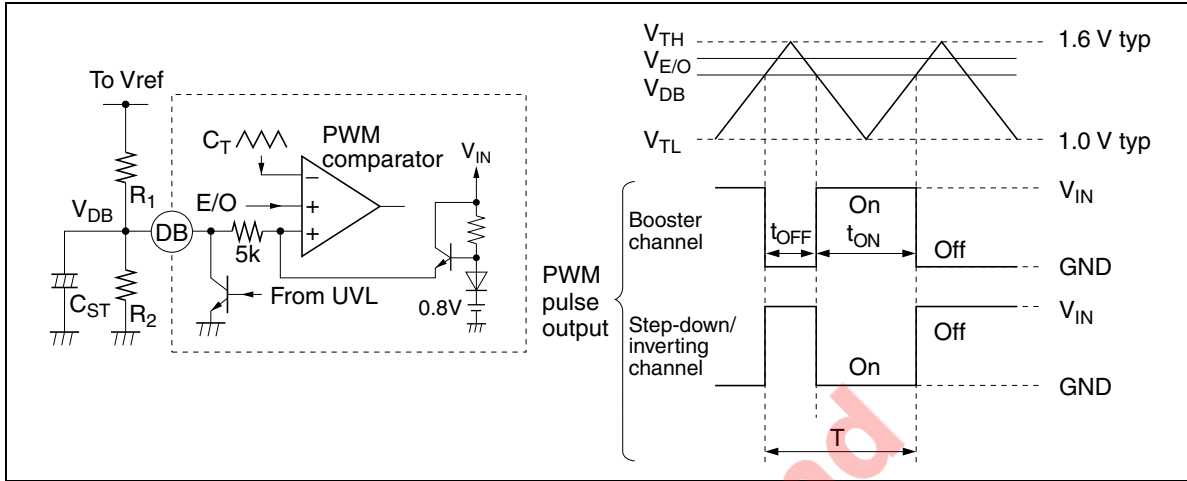

Figure 3.1 Dead Band Duty Setting

### 3.2 Soft Start (SST) Setting (each channel)

When the power is turned on, the soft start function gradually raises  $V_{DB}$  (refer to section 3.1), and the PWM output pulse width gradually widens. This function is realized by adding a capacitor  $C_{ST}$  to the DB pin. The function is realized as follows.

In the figure 3.2, the DB pin is clamped internally at approximately 0.8 V, which is 0.2 V lower than the triangle wave  $V_{TL} = 1.0$  V typ.

$t_A$ : Standby time until PWM pulse starts widening.

$t_B$ : Time during which SST is in effect.

During soft start, the DB pin voltage in the figure below is as expressed in the following equation.

$$V_{SST} = V_{DB} \cdot \left( 1 - e^{-\frac{t-t_{0.8}}{T}} \right), \quad t_{SST} = t_A + t_B$$

Here,

$$t_{0.8} = -T \ln \left( 1 - \frac{0.8}{V_{DB}} \right), \quad T = C_{ST} \cdot (R_1 // R_2)$$

How to select values: If the soft start time  $t_{SST}$  is too short, the DC/DC converter output voltage will tend to overshoot. To prevent this, set  $t_{SST}$  to a few tens of ms or above.

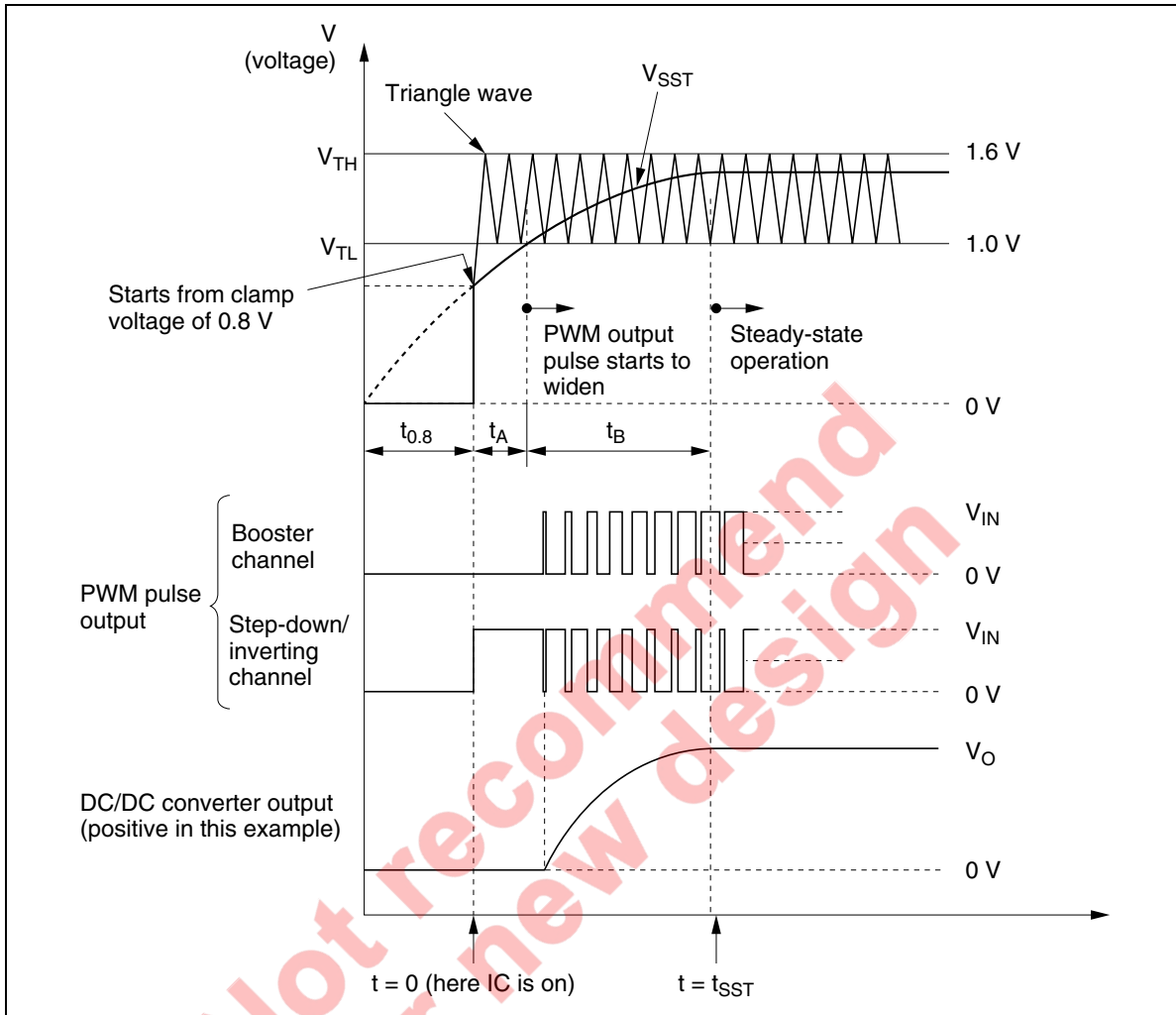

Figure 3.2 Soft Start (SST) Setting

#### 4. Totem Pole Output Stage Circuit and Power MOS FET Driving Method

The output stage of this IC series is configured of totem pole circuits, allowing direct connection to a power MOS FET as an external switching device, so long as  $V_{IN}$  is below the gate breakdown voltage.

If there is a possibility that  $V_{IN}$  will exceed the gate breakdown voltage of the power MOS FET, a Zener diode circuit like that shown figure 4.1 or other protective measures should be used. The figure 4.1 shows an example using a P-channel power MOS FET.

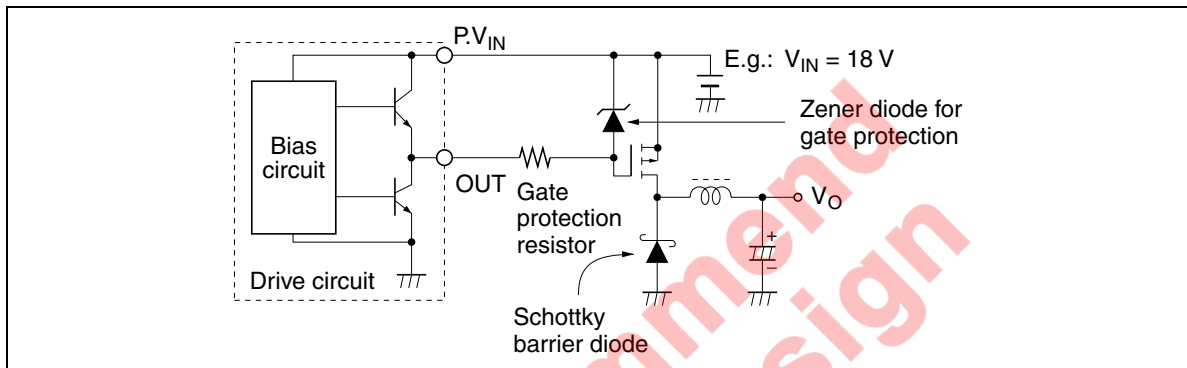

Figure 4.1 P-channel Power MOS FET (example)

#### 5. Vref Undervoltage Error Prevention (UVL) and Overvoltage Protection (OVP) Functions

##### 5.1 Operation Principles

The reference voltage circuit is equipped with UVL and OVP functions.

- UVL

In normal operation the  $V_{ref}$  output voltage is fixed at 2.5 V. If  $V_{IN}$  is lower than normal, the UVL circuit detects the  $V_{ref}$  output voltage with a hysteresis of 1.7 V and 2.0 V, and shuts off the PWM output if  $V_{ref}$  falls below this level, in order to prevent malfunction.

- OVP

The OVP circuit protects the IC from inadvertent application of a high voltage from outside, such as if  $V_{IN}$  is shorted. A Zener diode (5.6 V) and resistor are used between  $V_{ref}$  and GND for overvoltage detection. PWM output is shut off if  $V_{ref}$  exceeds approximately 7.0 V.

Note that the PWM output pulse logic and the precision of the switching regulator output voltage are not guaranteed at an applied voltage of 2.5 V to 7 V.

### 5.2 Quick Shutoff

When the UVL circuit goes into operation, a sink transistor is switched on as in the figure below, drawing off the excess current. This transistor also functions when the IC is turned off, drawing off current from the  $C_T$ , E/O, and DB pins and enabling quick shutoff.

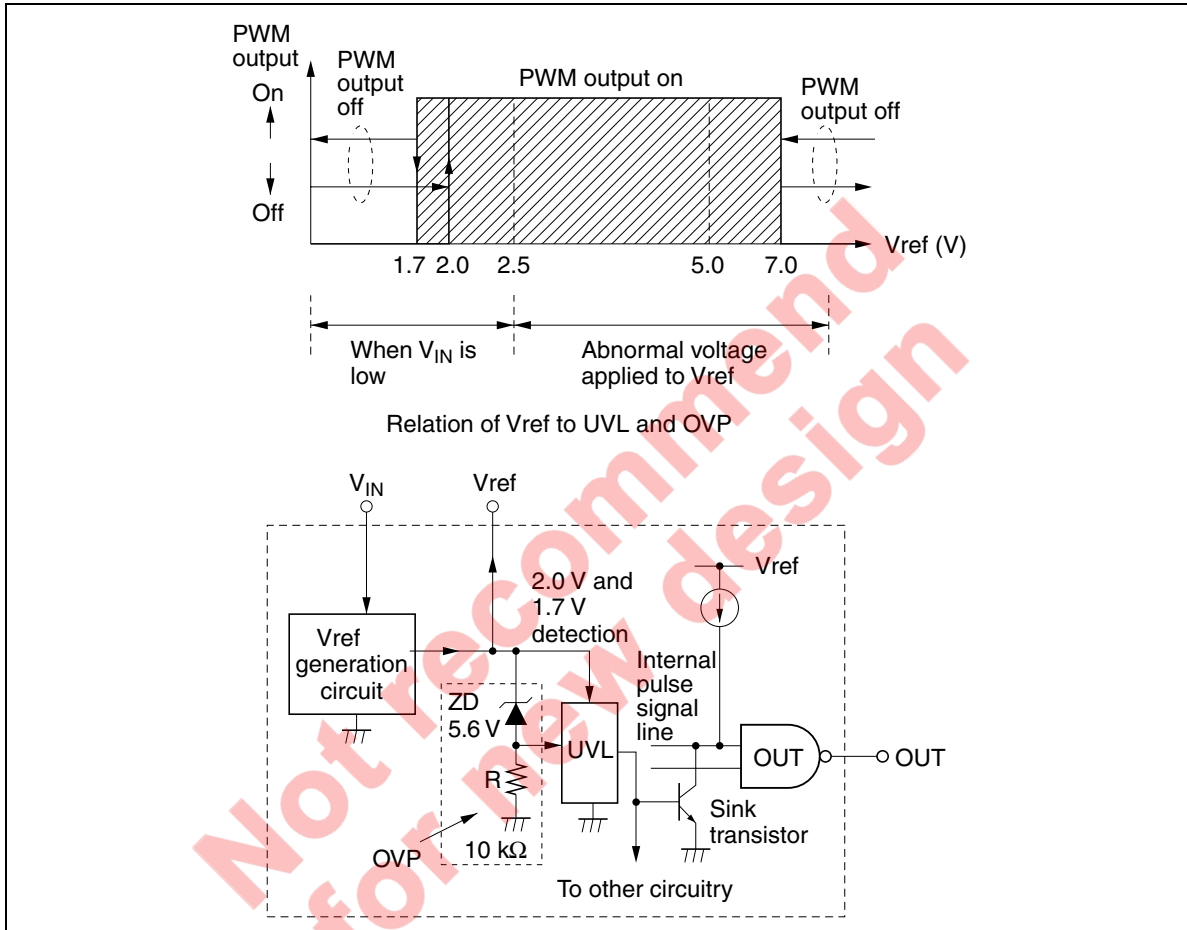

Figure 5.1 Quick Shutoff



## 6. Setting of Intermittent Operation Timing when Overcurrent is Detected

### 6.1 Operation Principles

The current limiter on this IC detects overcurrent in each output pulse, providing pulse-by-pulse overcurrent protection by limiting pulse output whenever an overcurrent is detected. If the overcurrent state continues, the TIM pin and ON/OFF pin can be used to operate the IC intermittently. As a result, a power supply with sharp vertical characteristics can be configured.

The ON/OFF timing for intermittent operation makes use of the hysteresis in the ON/OFF pin threshold voltage  $V_{ON}$  and  $V_{OFF}$ , such that  $V_{ON} - V_{OFF} = V_{BE}$ . Setting method is performed as described on the following pages.  $V_{BE}$  is based-emitter voltage of internal transistor.

Note: When an overcurrent is detected in one channel of this IC but not the other, the pulse-by-pulse current limiter still goes into operation on both channels. Also, when the intermittent operation feature is not used, the TIM pin should be set to open state and the ON/OFF pin pulled up to high level (above  $V_{ON}$ ).

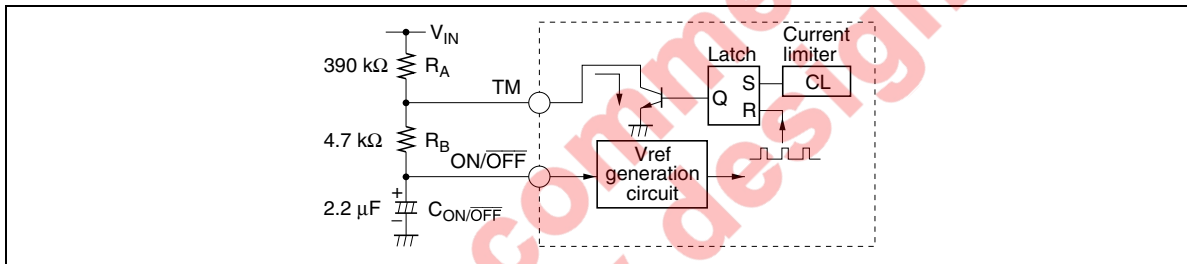

Figure 6.1 Connection Diagram (example)

### 6.2 Intermittent Operation Timing Chart ( $V_{ON/OFF}$ only)

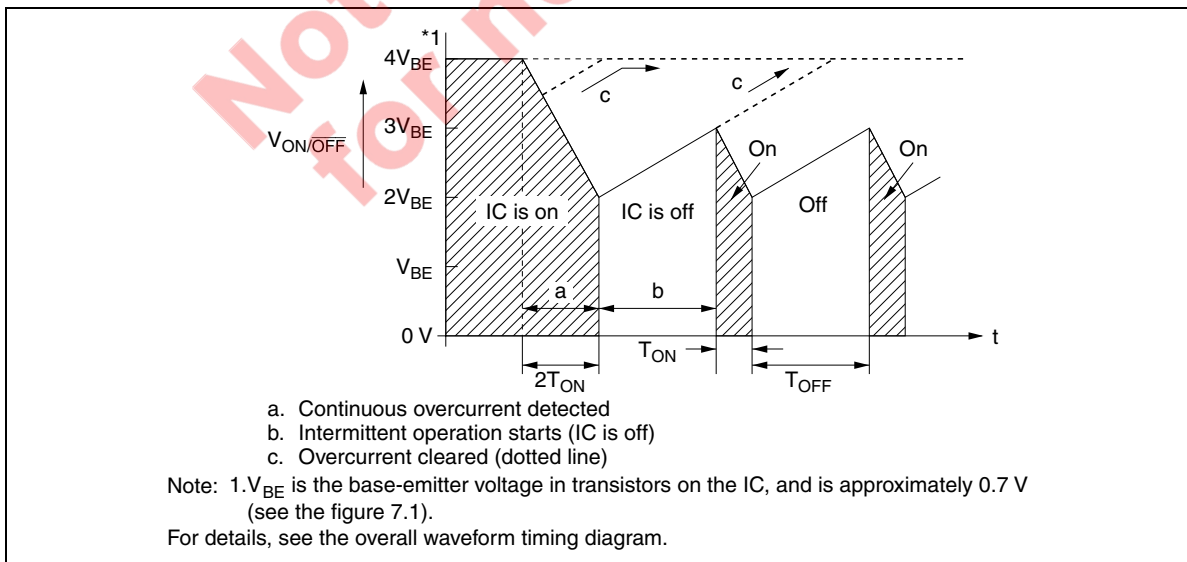

Figure 6.2 Intermittent Operation Timing Chart

### 6.3 Calculating Intermittent Operation Timing

Intermittent operation timing is calculated as follows.

(1)  $T_{ON}$  time (the time until the IC is shut off when continuous overcurrent occurs)

$$T_{ON} = C_{ON/OFF} \times R_B \times \ln \left( \frac{3V_{BE}}{2V_{BE}} \right) \times \left( \frac{1}{1 - \text{On duty}^*} \right)$$

$$= C_{ON/OFF} \times R_B \times \ln 1.5 \times \left( \frac{1}{1 - \text{On duty}^*} \right) \approx 0.4 \times C_{ON/OFF} \times R_B \times \left( \frac{1}{1 - \text{On duty}^*} \right)$$

(2)  $T_{OFF}$  time (when the IC is off, the time until it next goes on)

$$T_{OFF} = C_{ON/OFF} \times (R_A + R_B) \times \ln \left( \frac{V_{IN} - 2V_{BE}}{V_{IN} - 3V_{BE}} \right)$$

Where,  $V_{BE} \approx 0.7 \text{ V}$

Note: 1. On duty is the percent of time the IC is on during one PWM cycle when the pulse-by-pulse current limiter is operating.

From the first equation (1) above, it is seen that the shorter the time  $T_{ON}$  when the pulse-by-pulse current limiter goes into effect (resulting in a larger overload), the smaller the value  $T_{ON}$  becomes.

As seen in the second equation (2),  $T_{OFF}$  is a function of  $V_{IN}$ . Further, according to this setting, when  $V_{IN}$  is switched on, the IC goes on only after  $T_{OFF}$  has elapsed.

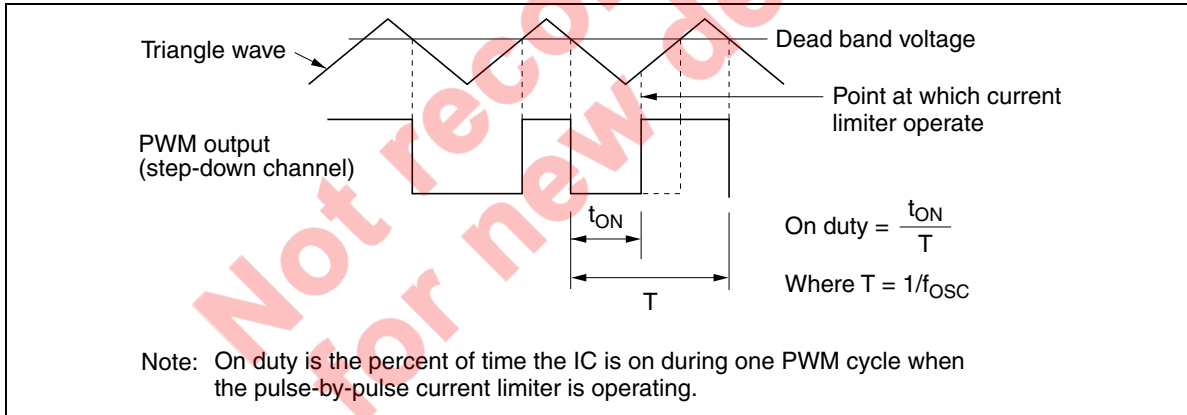

Figure 6.3

6.4 Examples of Intermittent Operation Timing (calculated values)

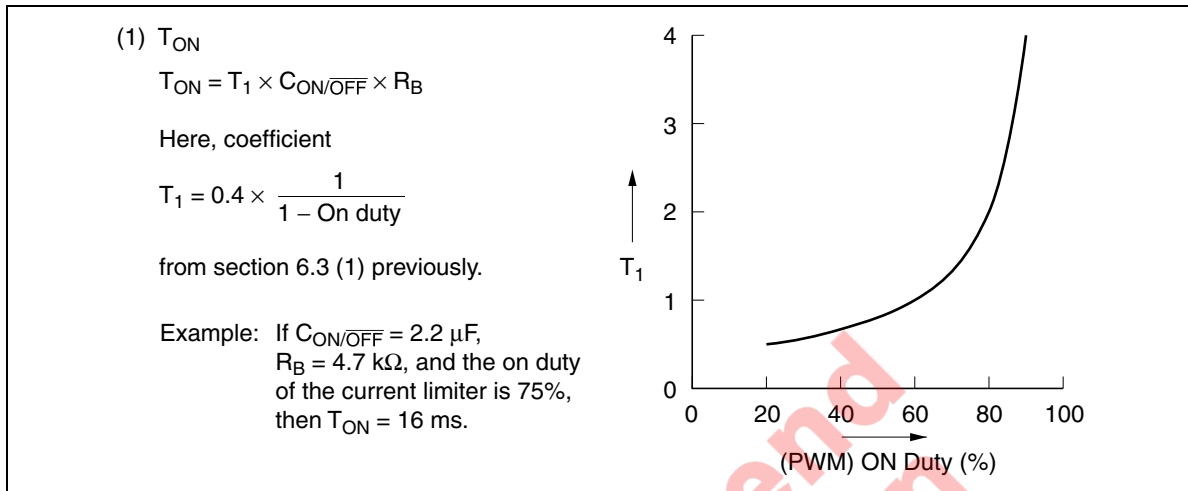

Figure 6.4 Examples of Intermittent Operation Timing (1)

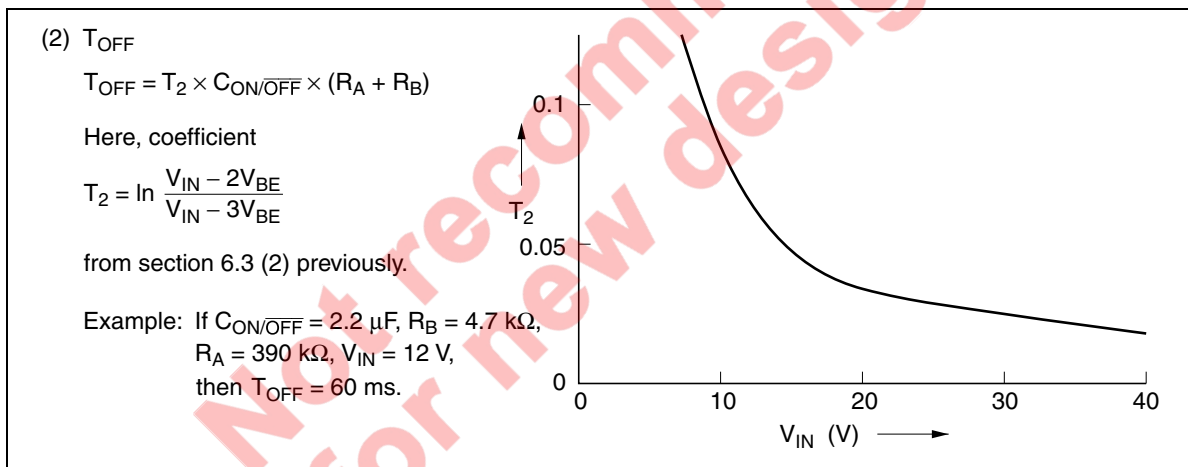

Figure 6.5 Examples of Intermittent Operation Timing (2)

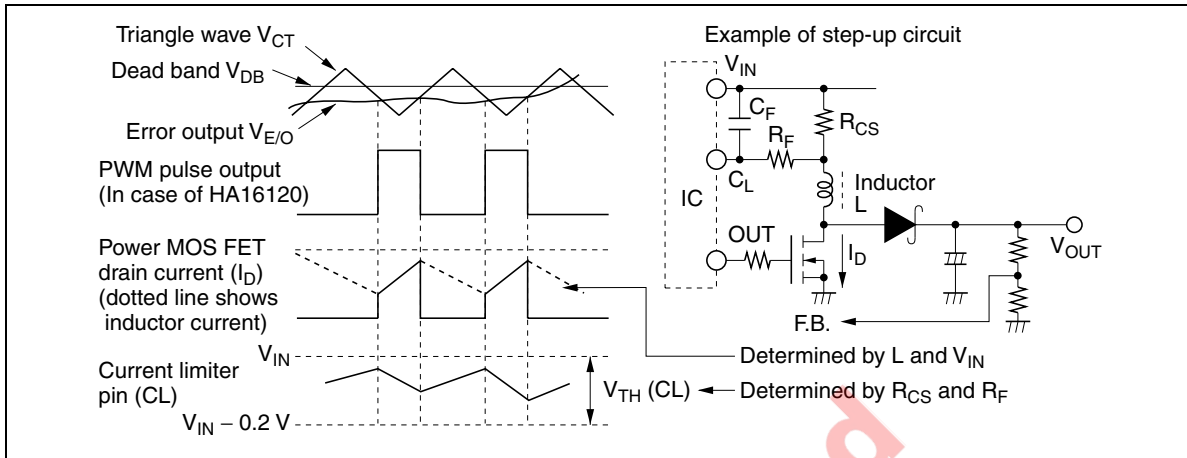

Figure 6.6

## 7. ON/OFF Pin Usage

### 7.1 IC Shutoff by the ON/OFF Pin

As shown in the figure 7.1, these ICs can be turned off safely by lowering the voltage at the ON/OFF pin to below  $2V_{BE}$ . This feature is used to conserve the power in the power supply system. In off state the IC current consumption ( $I_{OFF}$ ) is  $10 \mu A$  (Max) for HA16116 and  $150 \mu A$  (Max) for HA16121.

The ON/OFF pin can also be used to drive logic ICs such as TTL or CMOS with a sink current of  $50 \mu A$  (Typ) at an applied voltage of 5 V. When it is desired to employ this feature along with intermittent operation, an open collector or open drain logic IC should be used.

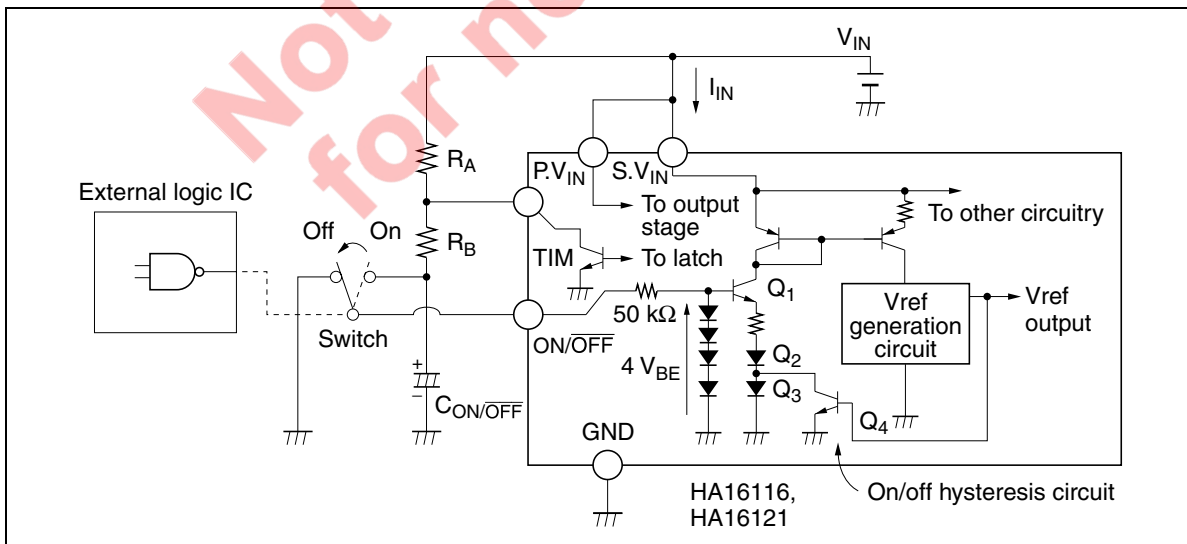

Figure 7.1 IC Shutoff by the ON/OFF Pin

**7.2 Adjusting UVL Voltage (when intermittent operation is not used)**

The UVL voltage setting in this IC series can be adjusted externally as shown below.

Using the relationships shown in the figure, the UVL voltage in relation to  $V_{IN}$  can be adjusted by changing the relative values of  $V_{TH}$  and  $V_{TL}$ .

When the IC is operating, transistor  $Q_4$  is off, so  $V_{ON} = 3V_{BE} \approx 2.1$  V. Accordingly, by connecting resistors  $R_C$  and  $R_D$ , the voltage at which UVL is cancelled is as follows.

$$V_{IN} = 2.1 \text{ V} \times \frac{R_C + R_D}{R_D}$$

This  $V_{IN}$  is simply the supply voltage at which the UVL stops functioning, so in this state  $V_{ref}$  is still below 2.5 V. In order to restore  $V_{ref}$  to 2.5 V, a  $V_{IN}$  of approximately 4.3 V should be applied.

With this IC series,  $V_{ON/OFF}$  makes use of the  $V_{BE}$  of internal transistors, so when designing a power supply system it should be noted that  $V_{ON}$  has a temperature dependency of around  $-6 \text{ mV}/^\circ\text{C}$ .

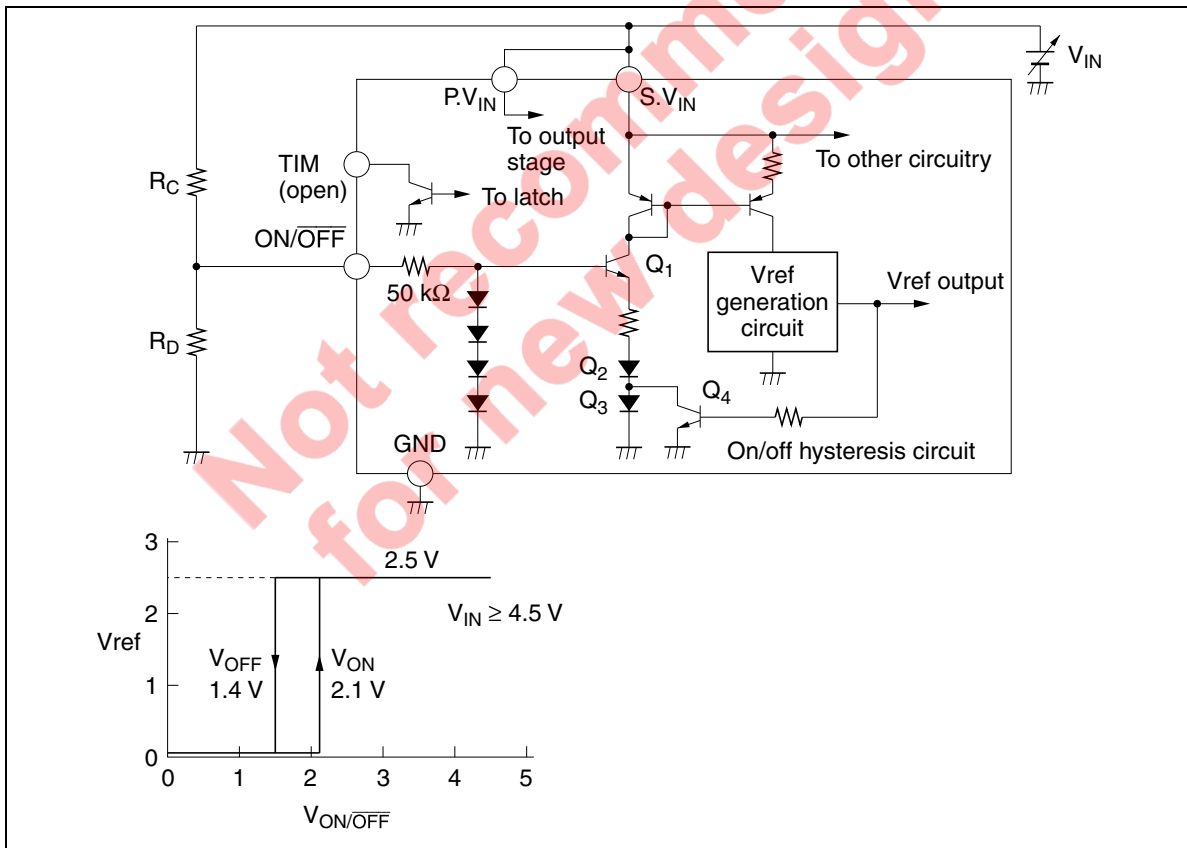

**Figure 7.2 Adjusting UVL Voltage**

**Overcurrent Detection Value Setting**

The overcurrent detection value  $V_{TH}$  for this IC series is 0.2 V (Typ) and the bias current is 200  $\mu$ A (Typ). The power MOS FET peak current value before the current limiter goes into operation is derived from the following equation.

$$I_D = \frac{V_{TCL} - (R_F + R_{CS}) \cdot I_{BCL}}{R_{CS}}$$

Here  $V_{TH} = V_{IN} - V_{CL} = 0.2$  V,  $V_{CL}$  is a voltage referred on GND.

Note that  $C_F$  and  $R_{CS}$  form a low-pass filter, determined by their time constants, that prevents malfunctions from current spikes when the power MOS FET is turned on or off.

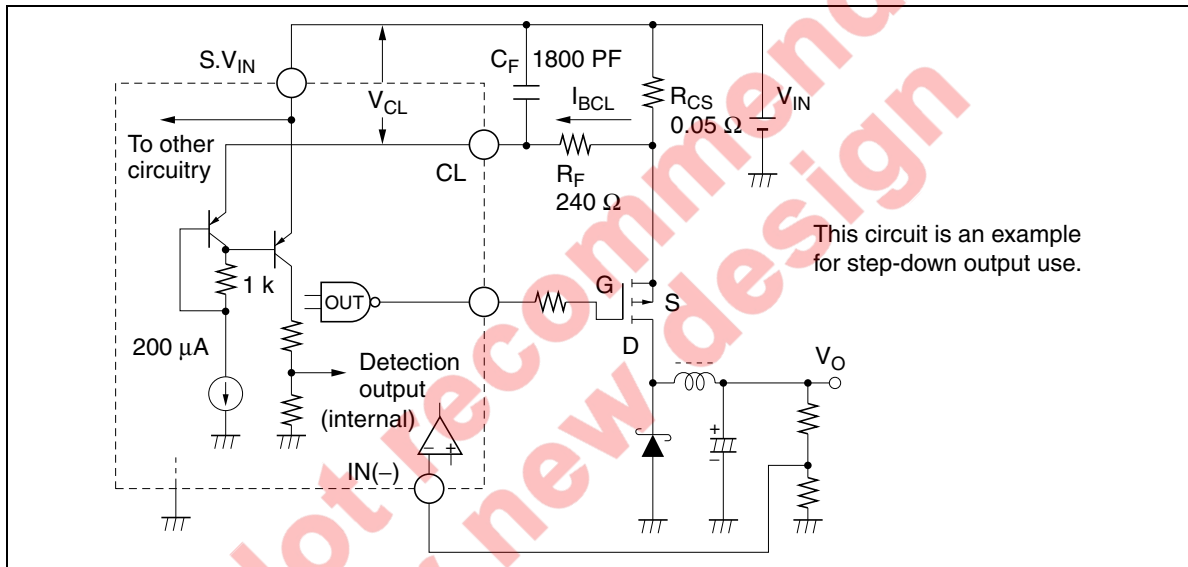

**Figure 8.1 Example for Step-Down Use**

The sample values given in this figure are calculated from the following equation.

$$I_D = \frac{0.2 \text{ V} - (240 \text{ } \Omega + 0.05 \text{ } \Omega) \times 200 \text{ } \mu\text{A}}{0.05 \text{ } \Omega} = 3.04 \text{ [A]}$$

The filter cutoff frequency is calculated as follows.

$$f_c = \frac{1}{2\pi C_F R_F} = \frac{1}{6.28 \times 1800 \text{ pF} \times 240 \text{ } \Omega} = 370 \text{ [kHz]}$$

**Absolute Maximum Ratings**

(Ta = 25°C)

Item	Symbol	Rating		Unit
		HA16116FP, HA16121FP	HA16116FPJ, HA16121FPJ	
Supply voltage	V <sub>IN</sub>	40	40	V
Output current (DC)	I <sub>O</sub>	±0.1	±0.1	A
Output current (peak)	I <sub>O peak</sub>	±1.0	±1.0	A
Current limiter pin voltage	V <sub>CL</sub>	V <sub>IN</sub>	V <sub>IN</sub>	V
Error amp input voltage	V <sub>IEA</sub>	V <sub>IN</sub>	V <sub>IN</sub>	V
E/O input voltage	V <sub>IEO</sub>	V <sub>ref</sub>	V <sub>ref</sub>	V
RT pin source current	I <sub>RT</sub>	500	500	μA
TIM pin sink current	I <sub>TM</sub>	20	20	mA
Power dissipation*1	P <sub>T</sub>	680*1	680*1	mW
Operation temperature range	Topr	-40 to +85	-40 to +85	°C
Junction temperature	TjMax	125	125	°C
Storage temperature range	Tstg	-55 to +125	-55 to +125	°C

Note: 1. This value is based on actual measurements on a 40 × 40 × 1.6 mm glass epoxy circuit board. At a wiring density of 10%, it is the permissible value up to Ta = 45°C, but at higher temperatures this value should be derated by 8.3 mW/°C. At a wiring density of 30% it is the permissible value up to Ta = 64°C, but at higher temperatures it should be derated by 11.1 mW/°C.

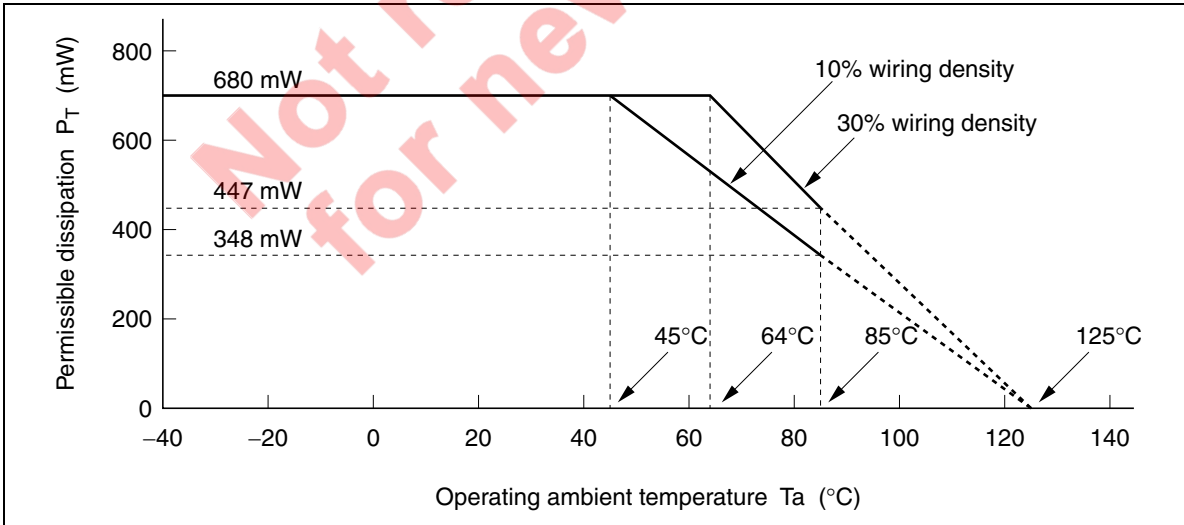

**Electrical Characteristics**

 (Ta = 25°C, V<sub>IN</sub> = 12 V, f<sub>OSC</sub> = 300 kHz)

Item	Symbol	Min	Typ	Max	Unit	Test Conditions	
Reference voltage block	Output voltage	Vref	2.45	2.50	2.55	V	I <sub>o</sub> = 1 mA
	Line regulation	Line	—	30	60	mV	4.5 V ≤ V <sub>IN</sub> ≤ 40 V
	Load regulation	Load	—	30	60	mV	0 ≤ I <sub>o</sub> ≤ 10 mA
	Output shorting current	I <sub>os</sub>	10	25	—	mA	Vref = 0 V
	Vref OVP voltage	Vrovp	6.2	6.8	7.0	V	
	Output voltage temperature dependence	ΔVref/ΔTa	—	100	—	ppm/°C	
Triangle wave oscillator block	Maximum oscillator frequency	f <sub>OSCmax</sub>	600	—	—	kHz	
	Minimum oscillator frequency	f <sub>OSCmin</sub>	—	—	1	Hz	
	Oscillator frequency input voltage stability	Δf <sub>OSC</sub> /ΔV <sub>IN</sub>	—	±1	±3	%	4.5 V ≤ V <sub>IN</sub> ≤ 40 V
	Oscillator frequency temperature stability	Δf <sub>OSC</sub> /ΔTa	—	±5	—	%	-20°C ≤ Ta ≤ 85°C
	Oscillator frequency	f <sub>OSC</sub>	270	300	330	kHz	C <sub>T</sub> = 220 pF, R <sub>T</sub> = 10 kΩ
Dead band adjust block	Low-level threshold voltage	V <sub>TLDB</sub>	0.87	0.97	1.07	V	Output on duty 0%
	High-level threshold voltage	V <sub>THDB</sub>	1.48	1.65	1.82	V	Output on duty 100%
	Threshold differential voltage	ΔV <sub>TDB</sub>	0.55	0.65	0.75	V	ΔV <sub>TH</sub> = V <sub>TH</sub> - V <sub>TL</sub>
	Output source current	I <sub>Osource (DB)</sub>	100	150	200	μA	DB pin = 0 V
PWM comparator block	Low-level threshold voltage	V <sub>TLCMP</sub>	0.87	0.97	1.07	V	Output on duty = 0%
	High-level threshold voltage	V <sub>THCMP</sub>	1.48	1.65	1.82	V	Output on duty = 100%
	Threshold differential voltage	ΔV <sub>TCMP</sub>	0.55	0.65	0.75	V	ΔV <sub>TH</sub> = V <sub>TH</sub> - V <sub>TL</sub>
	Dead band precision	DBdev	-5	0	+5	%	Deviation when V <sub>EO</sub> = (V <sub>TL</sub> + V <sub>TH</sub> )/2, duty = 50 %



**Electrical Characteristics (cont.)**

 (Ta = 25°C, V<sub>IN</sub> = 12 V, f<sub>OSC</sub> = 300 kHz)

Item	Symbol	Min	Typ	Max	Unit	Test Conditions	
Error amp block	Input offset voltage	V <sub>IOEA</sub>	—	2	10	mV	
	Input bias current	I <sub>BEA</sub>	—	0.8	2	μA	
	Output sink current	I <sub>Osink (EA)</sub>	28	40	52	μA	In open loop, V <sub>I</sub> = 3 V, V <sub>O</sub> = 2 V
	Output source current	I <sub>Osource (EA)</sub>	28	40	52	μA	In open loop, V <sub>I</sub> = 2 V, V <sub>O</sub> = 1 V
	Voltage gain	A <sub>V</sub>	40	50	—	dB	f = 10 kHz
	Unity gain band-width	BW	3	4	—	MHz	
	High-level output voltage	V <sub>OHEA</sub>	2.2	3.0	—	V	I <sub>O</sub> = 10 μA
	Low-level output voltage	V <sub>OLEA</sub>	—	0.2	0.5	V	I <sub>O</sub> = 10 μA
Overcurrent detection block	Threshold voltage	V <sub>TCL</sub>	V <sub>IN</sub> -0.22	V <sub>IN</sub> -0.2	V <sub>IN</sub> -0.18	V	
	CL bias current	I <sub>BCL</sub>	150	200	250	μA	C <sub>L</sub> = V <sub>IN</sub>
	Operating time	t <sub>OFFCL</sub>	—	200	300	ns	C <sub>L</sub> = V <sub>IN</sub> -0.3 V
—			500	600	ns	Applies only to ch 2 of HA16121	
Output stage	Output low voltage	V <sub>OL1</sub>	—	0.7	2.2	V	I <sub>Osink</sub> = 10 mA Applies only to HA16116
			—	1.6	1.9	V	I <sub>Osink</sub> = 10 mA Applies only to HA16121
			—	1.0	1.3	V	I <sub>Osink</sub> = 0 mA Applies only to HA16121
	Off state low voltage	V <sub>OL2</sub>	—	1.6	1.9	V	I <sub>Osink</sub> = 1 mA ON/OFF pin = 0 V Applies only to ch 2 of HA16121
			—	1.0	1.3	V	I <sub>Osink</sub> = 0 mA ON/OFF = 0 V Applies only to ch 2 of HA16121
	Output high voltage	V <sub>OH1</sub>	V <sub>IN</sub> -1.9	V <sub>IN</sub> -1.6	—	V	I <sub>Osource</sub> = 10 mA
			V <sub>IN</sub> -1.3	V <sub>IN</sub> -1.0	—	V	I <sub>Osource</sub> = 0 A
	Off state high voltage	V <sub>OH2</sub>	V <sub>IN</sub> -1.9	V <sub>IN</sub> -1.6	—	V	I <sub>Osource</sub> = 1 mA ON/OFF pin = 0 V
			V <sub>IN</sub> -1.3	V <sub>IN</sub> -1.0	—	V	I <sub>Osource</sub> = 0 A ON/OFF pin = 0 V
	Rise time	t <sub>r</sub>	—	70	130	ns	C <sub>L</sub> = 1000 pF (to V <sub>IN</sub> ) *1, *2
Fall time	t <sub>f</sub>	—	70	130	ns	C <sub>L</sub> = 1000 pF (to V <sub>IN</sub> ) *1, *2	

## HA16116FP/FPJ, HA16121FP/FPJ

### Electrical Characteristics (cont.)

( $T_a = 25^\circ\text{C}$ ,  $V_{IN} = 12\text{ V}$ ,  $f_{OSC} = 300\text{ kHz}$ )

Item		Symbol	Min	Typ	Max	Unit	Test Conditions
UVL block	$V_{IN}$ high-level threshold voltage	$V_{TUH1}$	3.3	3.6	3.9	V	
	$V_{IN}$ low-level threshold voltage	$V_{TUL1}$	3.0	3.3	3.6	V	
	$V_{IN}$ threshold differential voltage	$\Delta V_{TU1}$	0.1	0.3	0.5	V	$\Delta V_{TU1} = V_{TUH1} - V_{TUL1}$
	Vref high-level threshold voltage	$V_{TUH2}$	1.7	2.0	2.3	V	
	Vref low-level threshold voltage	$V_{TUL2}$	1.4	1.7	2.0	V	
	Vref threshold differential voltage	$\Delta V_{TU2}$	0.1	0.3	0.5	V	$\Delta V_{TU2} = V_{TUH2} - V_{TUL2}$
ON/OFF block	ON/OFF pin sink current	$I_{ON/OFF}$	—	35	50	$\mu\text{A}$	ON/OFF pin = 5 V
	IC on-state voltage	$V_{ON}$	1.8	2.1	2.4	V	
	IC off-state voltage	$V_{OFF}$	1.1	1.4	1.7	V	
	ON/OFF threshold differential voltage	$\Delta V_{ON/OFF}$	0.5	0.7	0.9	V	
TIM block	TIM pin sink current in steady state	$I_{TIM1}$	0	—	10	$\mu\text{A}$	CL pin = $V_{IN}$ , $V_{TIM} = 0.3\text{ V}$
	TIM pin sink current at overcurrent detection	$I_{TIM2}$	10	15	20	mA	CL pin = $V_{IN} - 0.3\text{ V}$ $V_{TIM} = 0.3\text{ V}$
Common block	Operating current	$I_{IN}$	6.0	8.5	11.1	mA	$C_L = 0\text{ pF}$ (to $V_{IN}$ ) *1, *2
			8.5	12.1	15.7	mA	$C_L = 500\text{ pF}$ (to $V_{IN}$ ) *1, *2
			11.0	15.7	20.5	mA	$C_L = 1000\text{ pF}$ (to $V_{IN}$ ) *1, *2
	Off current	$I_{OFF}$	0	—	10	$\mu\text{A}$	HA16116FP ON/OFF pin = 0 V
0			120	150	$\mu\text{A}$	HA16121FP	

Notes: 1.  $C_L$  is load capacitor for Power MOS FET's gate, and  $C_L = 1000\text{ pF}$  to GND in the case of HA16121 – ch 2.

2.  $C_L$  in channel 2 of HA16121 is connected to GND.

Characteristic Curves

- Reference Voltage Block (Vref)

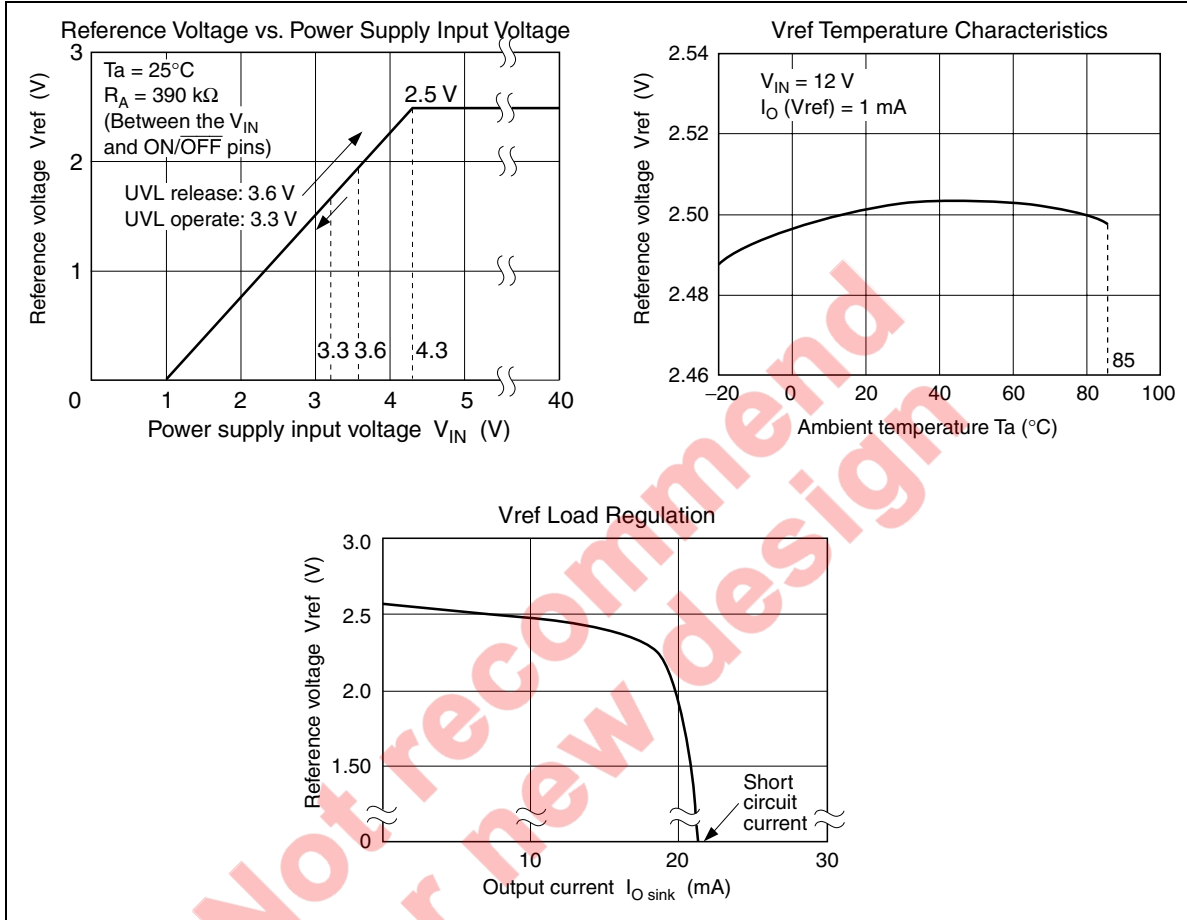

- UVL (Low Input Voltage Malfunction Prevention) Block

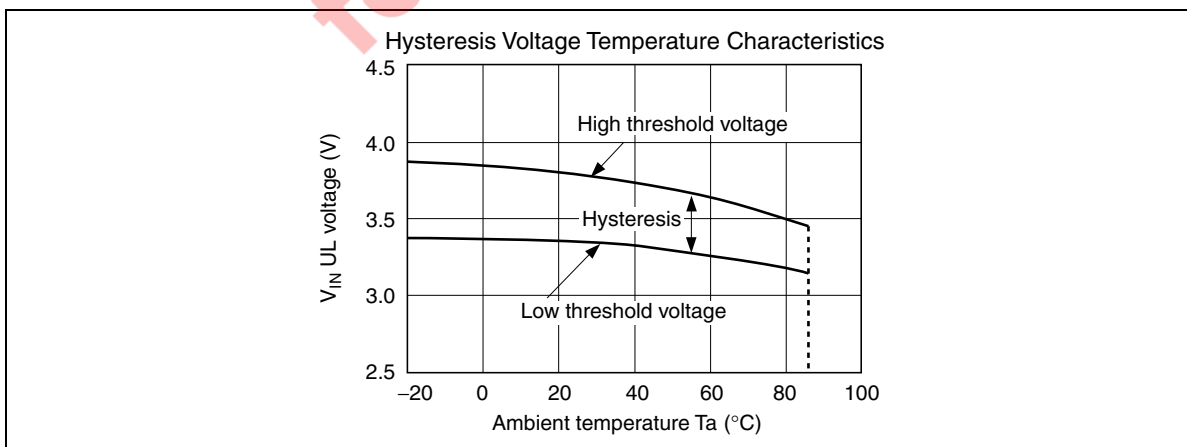

• Triangle Wave Oscillator Block

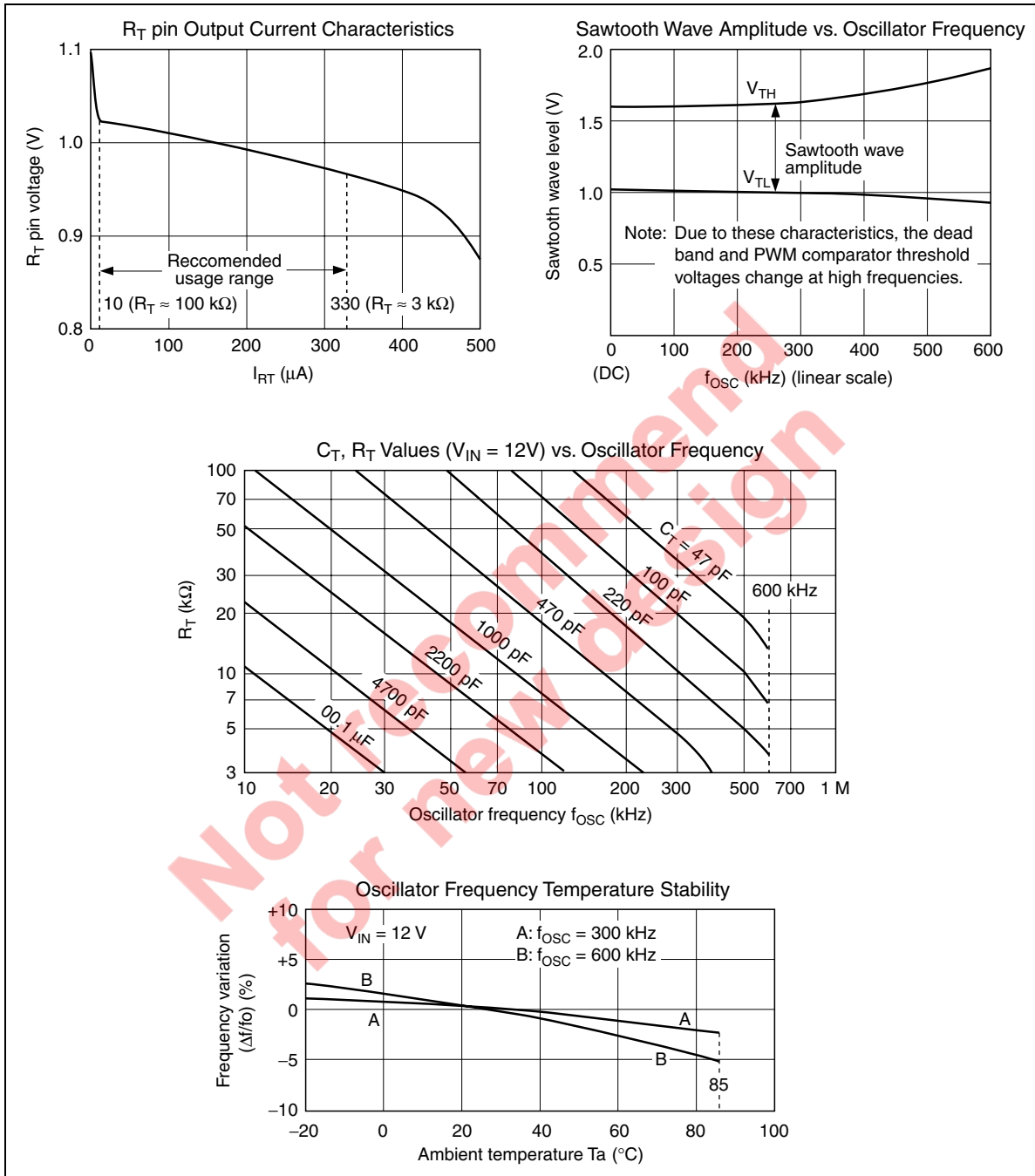

• Error Amplifier Block

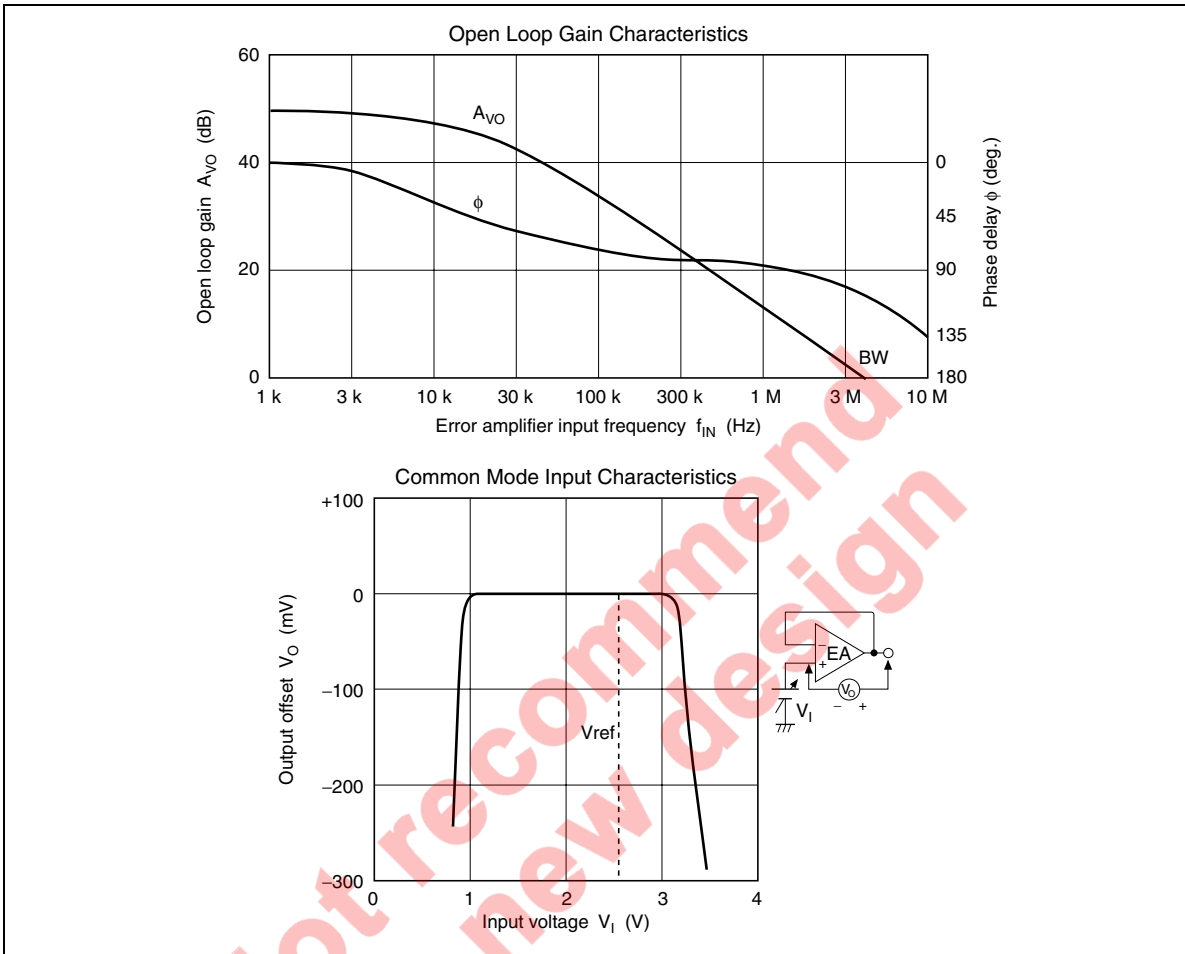

• On Duty Characteristics

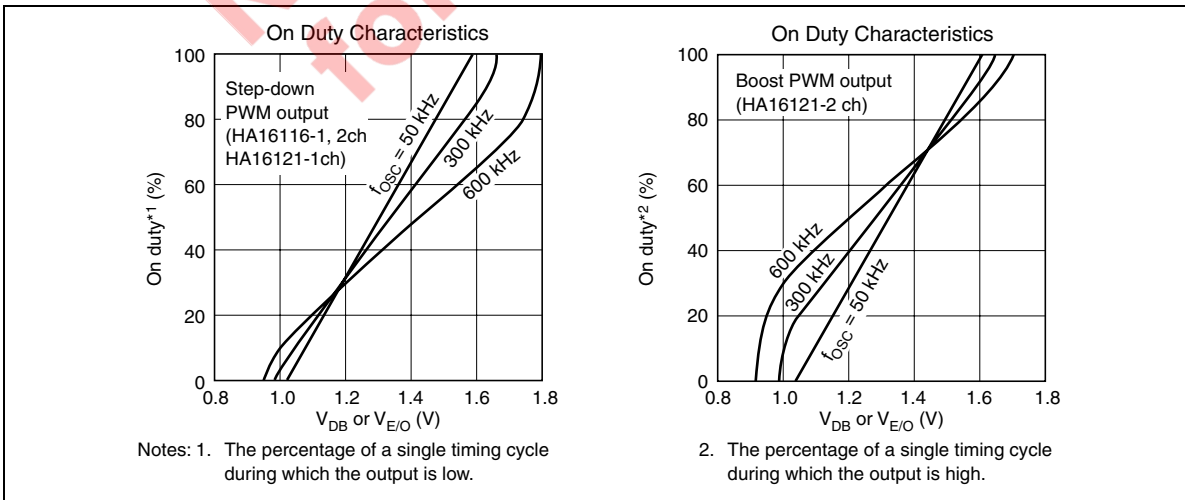

# HA16116FP/FPJ, HA16121FP/FPJ

- Other Characteristics

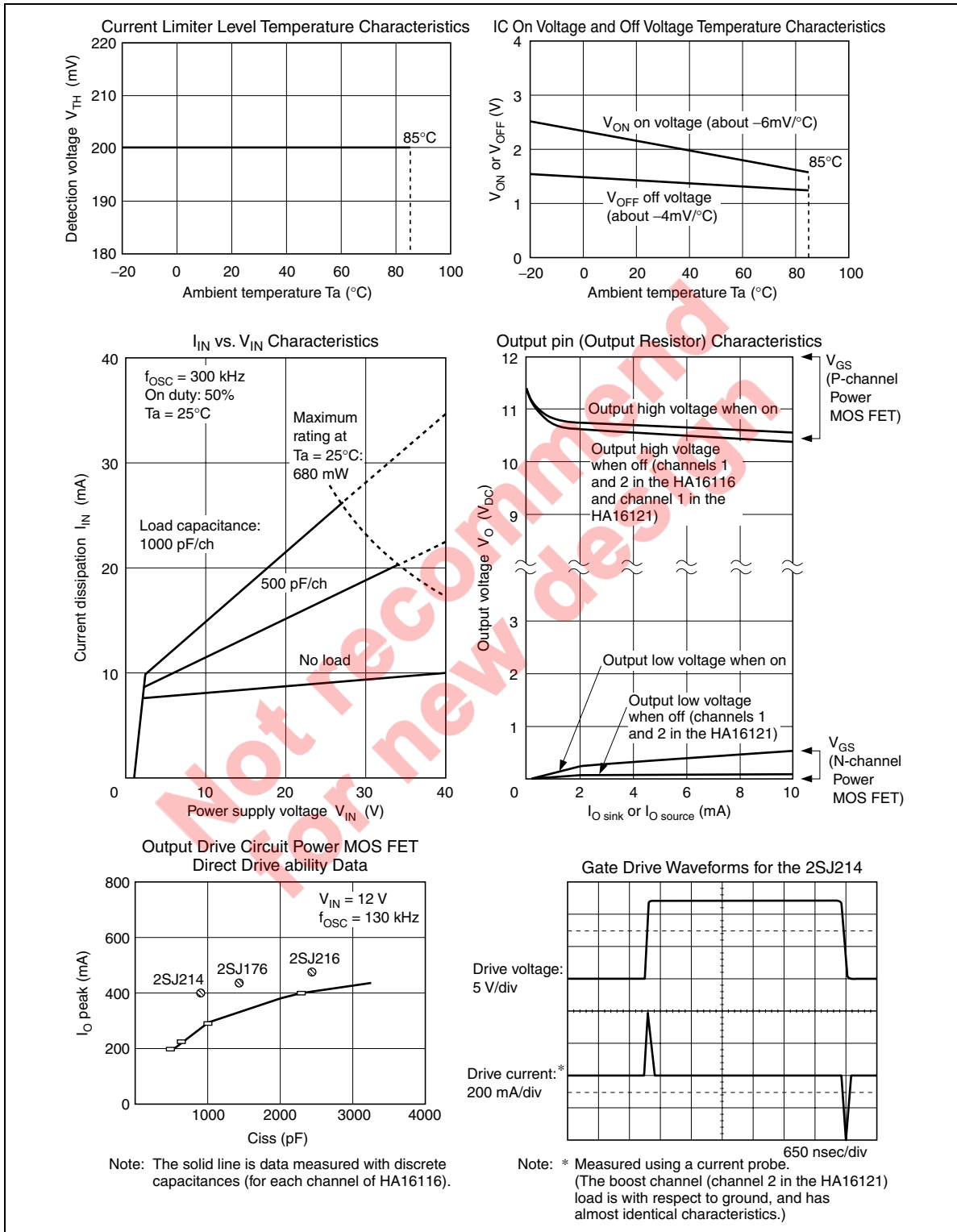

Application Examples (1)

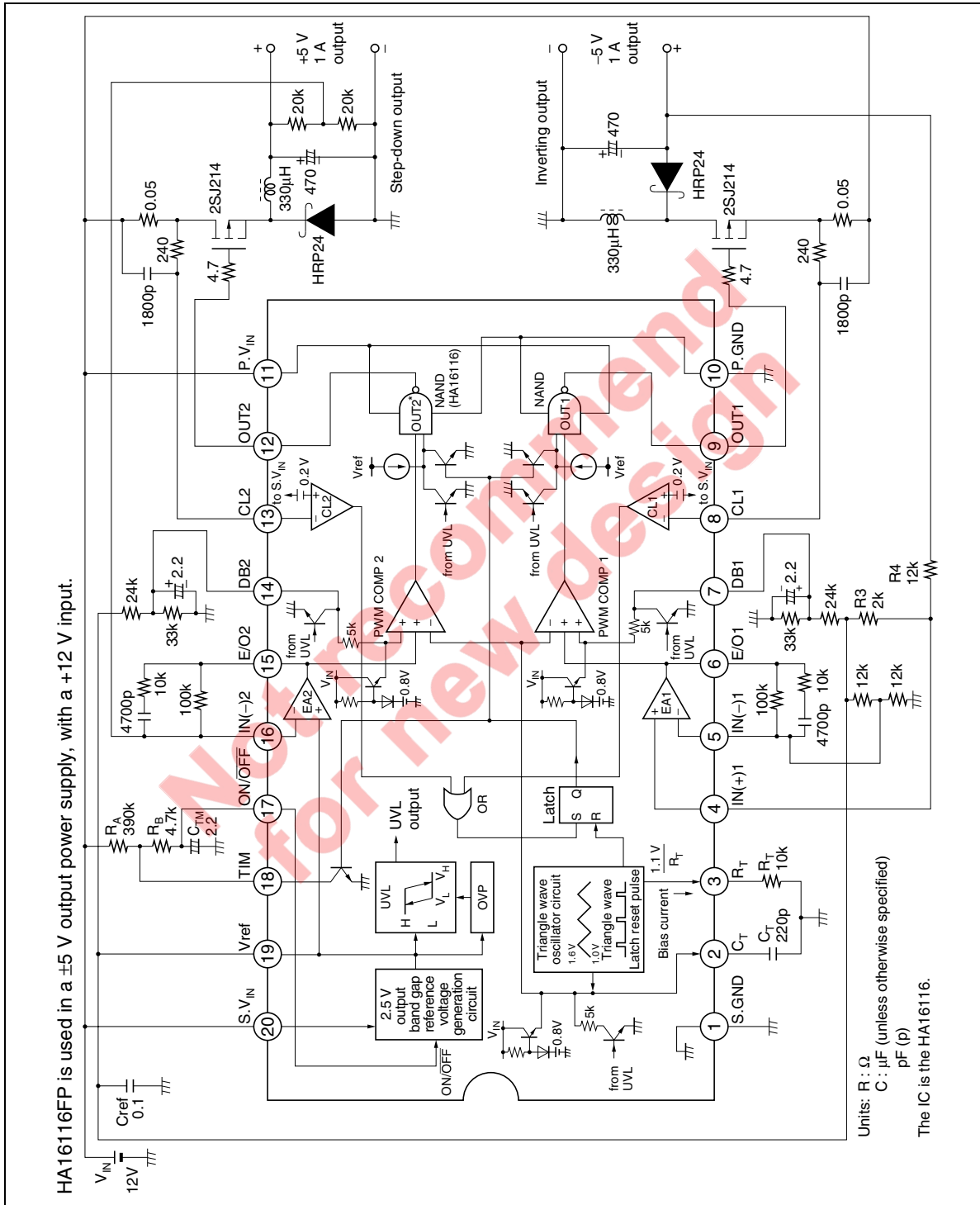

Overall Waveform Timing Diagram (for Application Examples (1))

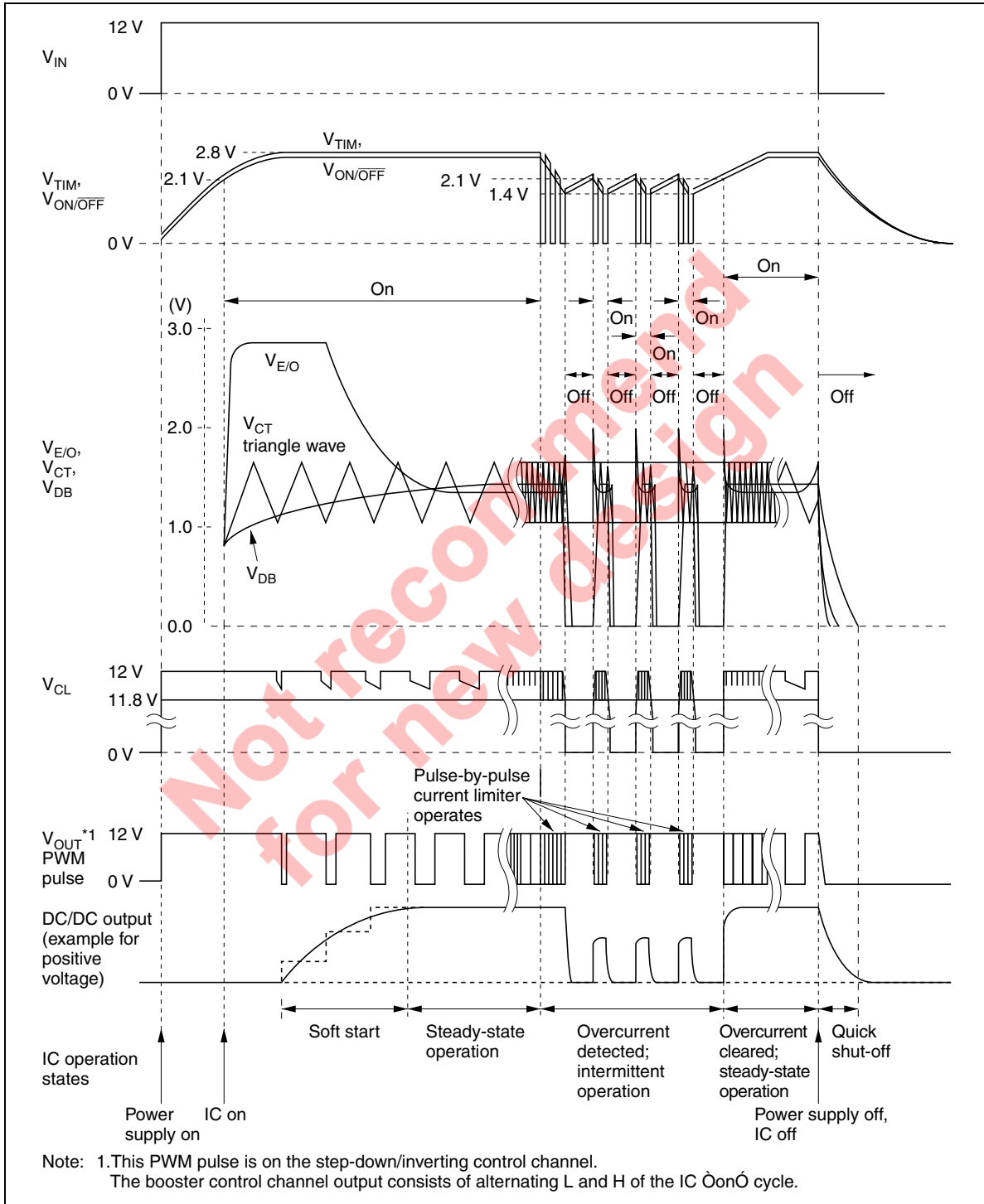



**Application Examples (2) (Some Pointers on Use)**

1. Inductor, Power MOS FET, and Diode Connections

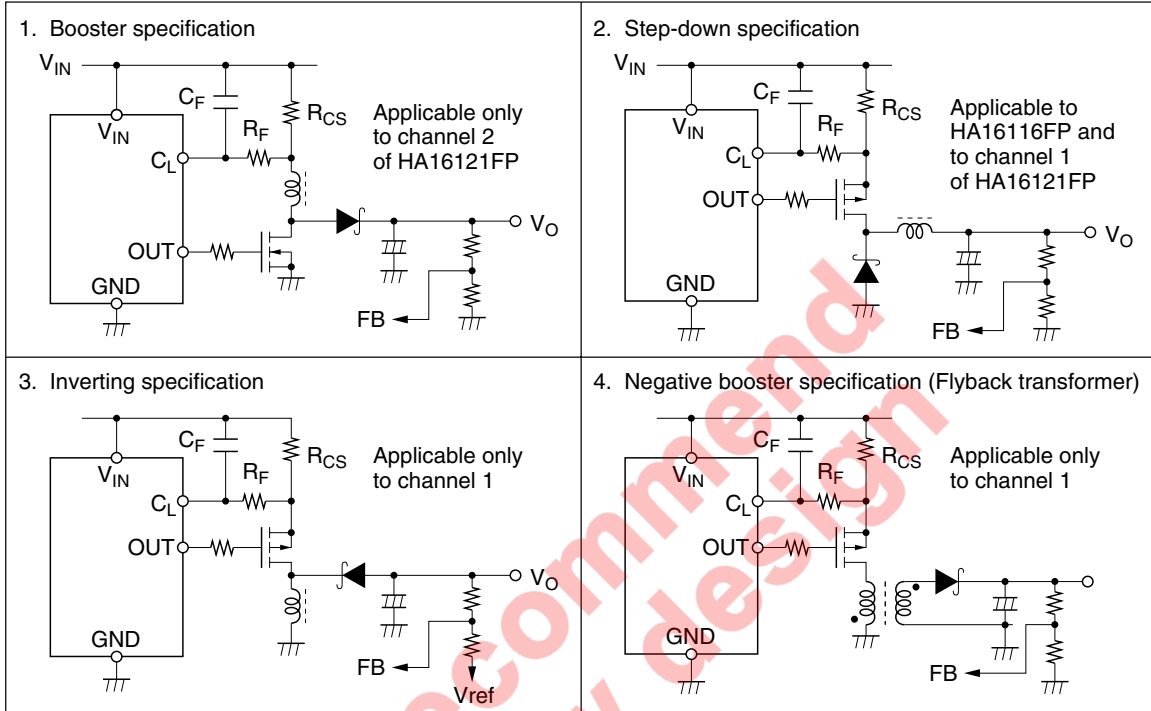

2. Turning Output On and Off while the IC is On

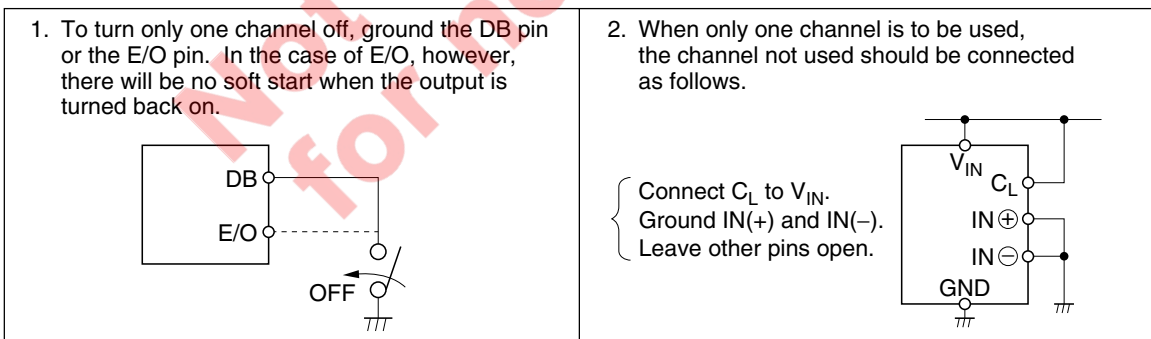



Package Dimensions

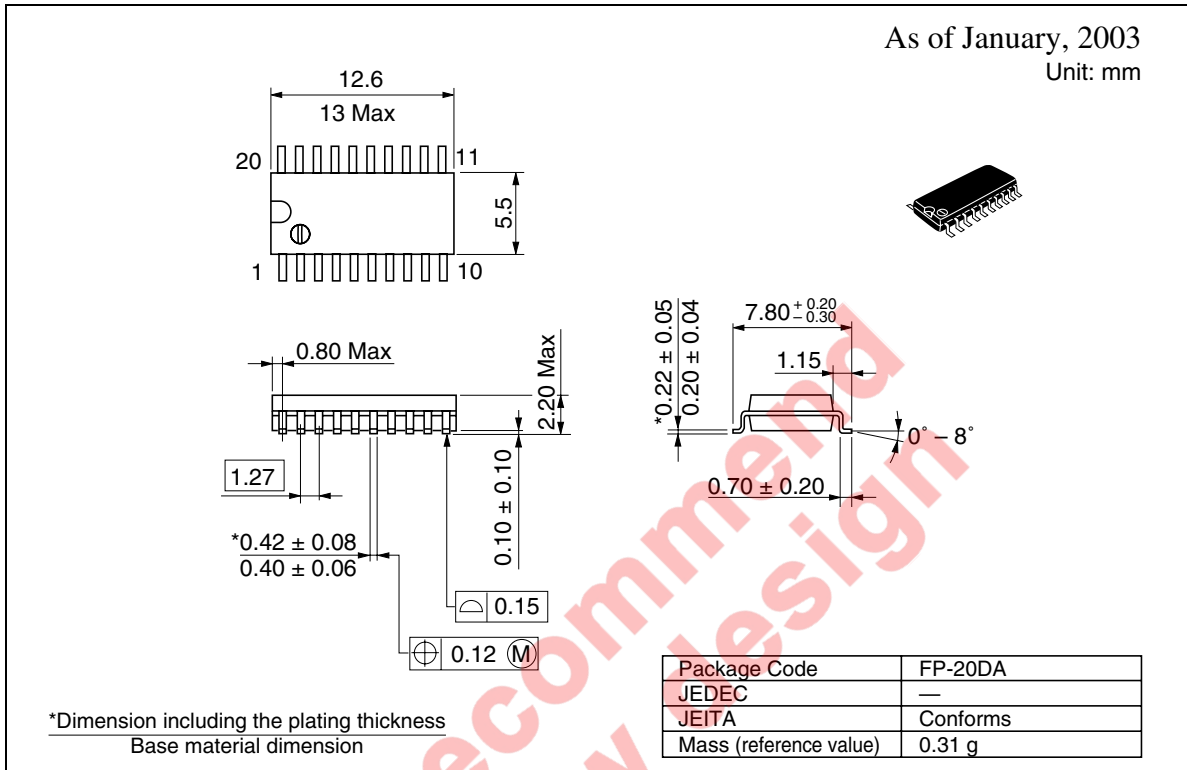

## Renesas Technology Corp. Sales Strategic Planning Div. Nippon Bldg., 2-6-2, Ohte-machi, Chiyoda-ku, Tokyo 100-0004, Japan

Keep safety first in your circuit designs!

1. Renesas Technology Corp. puts the maximum effort into making semiconductor products better and more reliable, but there is always the possibility that trouble may occur with them. Trouble with semiconductors may lead to personal injury, fire or property damage.  
Remember to give due consideration to safety when making your circuit designs, with appropriate measures such as (i) placement of substitutive, auxiliary circuits, (ii) use of nonflammable material or (iii) prevention against any malfunction or mishap.

Notes regarding these materials

1. These materials are intended as a reference to assist our customers in the selection of the Renesas Technology Corp. product best suited to the customer's application; they do not convey any license under any intellectual property rights, or any other rights, belonging to Renesas Technology Corp. or a third party.
2. Renesas Technology Corp. assumes no responsibility for any damage, or infringement of any third-party's rights, originating in the use of any product data, diagrams, charts, programs, algorithms, or circuit application examples contained in these materials.
3. All information contained in these materials, including product data, diagrams, charts, programs and algorithms represents information on products at the time of publication of these materials, and are subject to change by Renesas Technology Corp. without notice due to product improvements or other reasons. It is therefore recommended that customers contact Renesas Technology Corp. or an authorized Renesas Technology Corp. product distributor for the latest product information before purchasing a product listed herein.  
The information described here may contain technical inaccuracies or typographical errors.  
Renesas Technology Corp. assumes no responsibility for any damage, liability, or other loss rising from these inaccuracies or errors.  
Please also pay attention to information published by Renesas Technology Corp. by various means, including the Renesas Technology Corp. Semiconductor home page (<http://www.renesas.com>).
4. When using any or all of the information contained in these materials, including product data, diagrams, charts, programs, and algorithms, please be sure to evaluate all information as a total system before making a final decision on the applicability of the information and products. Renesas Technology Corp. assumes no responsibility for any damage, liability or other loss resulting from the information contained herein.
5. Renesas Technology Corp. semiconductors are not designed or manufactured for use in a device or system that is used under circumstances in which human life is potentially at stake. Please contact Renesas Technology Corp. or an authorized Renesas Technology Corp. product distributor when considering the use of a product contained herein for any specific purposes, such as apparatus or systems for transportation, vehicular, medical, aerospace, nuclear, or undersea repeater use.
6. The prior written approval of Renesas Technology Corp. is necessary to reprint or reproduce in whole or in part these materials.
7. If these products or technologies are subject to the Japanese export control restrictions, they must be exported under a license from the Japanese government and cannot be imported into a country other than the approved destination.  
Any diversion or reexport contrary to the export control laws and regulations of Japan and/or the country of destination is prohibited.
8. Please contact Renesas Technology Corp. for further details on these materials or the products contained therein.



### RENESAS SALES OFFICES

<http://www.renesas.com>

**Renesas Technology America, Inc.**  
450 Holger Way, San Jose, CA 95134-1368, U.S.A  
Tel: <1> (408) 382-7500 Fax: <1> (408) 382-7501

**Renesas Technology Europe Limited.**  
Dukes Meadow, Millboard Road, Bourne End, Buckinghamshire, SL8 5FH, United Kingdom  
Tel: <44> (1628) 585 100, Fax: <44> (1628) 585 900

**Renesas Technology Europe GmbH**  
Dornacher Str. 3, D-85622 Feldkirchen, Germany  
Tel: <49> (89) 380 70 0, Fax: <49> (89) 929 30 11

**Renesas Technology Hong Kong Ltd.**  
7/F., North Tower, World Finance Centre, Harbour City, Canton Road, Hong Kong  
Tel: <852> 2265-6688, Fax: <852> 2375-6836

**Renesas Technology Taiwan Co., Ltd.**  
FL 10, #99, Fu-Hsing N. Rd., Taipei, Taiwan  
Tel: <886> (2) 2715-2888, Fax: <886> (2) 2713-2999

**Renesas Technology (Shanghai) Co., Ltd.**  
26/F., Ruijin Building, No.205 Maoming Road (S), Shanghai 200020, China  
Tel: <86> (21) 6472-1001, Fax: <86> (21) 6415-2952

**Renesas Technology Singapore Pte. Ltd.**  
1, Harbour Front Avenue, #06-10, Keppel Bay Tower, Singapore 098632  
Tel: <65> 6213-0200, Fax: <65> 6278-8001