

MODULAR JACK WITH LED & INTEGRATED MAGNETICS SMT TYPE

1.0 SCOPE

This Product Specification covers the modular jack connector series with selective gold and tin plating for IR reflow application.

2.0 PRODUCT DESCRIPTION

2.1 PRODUCT NAME AND SERIES NUMBER(S)

Modular Jack SMT with Integrated Magnetics with LED SMT;
P/N: 48074-9101 /9103.

2.2 DIMENSIONS, MATERIALS, PLATINGS AND MARKINGS

See the appropriate sales drawings (SD-48074-102/103) for information on dimensions, materials, plating, and markings.

3.0 APPLICABLE DOCUMENTS AND SPECIFICATIONS

3.1 INDUSTRY DOCUMENTS

FCC Rules and Regulations, Part 68, Subpart F
IEC-60603-7

3.2 MOLEX DOCUMENTS

See the appropriate sales drawing for the necessary referenced documents and specifications

Note that in terms of conflicting info, the Molex Sales Drawing takes precedence followed by Molex PS.

4.0 RATINGS OF CONNECTOR

1. Current rating: 1.5 Amps @ 25°C
Voltage rating: 5.5 VDC Max
2. Operating temperature:
-40°C to + 85°C

THIS DOCUMENT CONTAINS INFORMATION THAT IS PROPRIETARY TO MOLEX ELECTRONIC TECHNOLOGIES, LLC AND SHOULD NOT BE USED WITHOUT WRITTEN PERMISSION

REVISION DESCRIPTION	OBSOLETE PART NUMBER AS PER PCN 508518			MODULAR JACK WITH LED & INTEGRATED MAGNETICS SMT TYPE			
CHANGE NO.	671087						
REVISED BY	RPRABHUM	DATE	2021/05/26	DOC TYPE	DOC TYPE DESCRIPTION	DOC PART	SERIES
REV APPR BY	GGA	DATE	2021/08/06	PS	PRODUCT SPECIFICATION WORD	001	48074
INITIAL RELEASE				CUSTOMER	DOCUMENT NUMBER	REVISION	SHEET
INITIAL DRWN	FYANG05	DATE	2014/09/25	GENERAL MARKET	PS-48074-006	C	1 OF 7
INITIAL APPR	RZHANG	DATE	2015/03/12				

5.0 PERFORMANCE

ITEM	DESCRIPTION	TEST CONDITION	REQUIREMENT
1	Examination of product	Visual, dimensional, and functional per applicable quality inspection plan.	Product shall meet requirements of applicable product drawing and specification.

5.1 ELECTRICAL REQUIREMENTS

ITEM	DESCRIPTION	TEST CONDITION	REQUIREMENT
2	DC Resistance(LLC R)	Apply a maximum voltage of 20 mV and a current of 100 mA . (Measure J6 to J3 , J2 to J1)	1.2 Ω MAXIMUM
3	Insulation Resistance	Unmated connector, apply a voltage of 100 VDC ±15V DC between adjacent terminals(J1~J8) and between terminals to ground(J1~J8 TO Shell).	500 Megohms MINIMUM
4	Current Temperature Rating	Mate connector, and apply the maintenance current 1.5A and measure the temperature rise when thermal stability is achieved.	30°C rise MAXIMUM from initial.
5	Dielectric Withstanding Voltage	1500 VAC rms (1.5mA cutoff current) for 60 seconds (See Schematic 7).	No Breakdown
		2250 VDC rms (1.5mA cutoff current) for 60 seconds (See Schematic 7).	

5.2 MECHANICAL REQUIREMENTS

ITEM	DESCRIPTION	TEST CONDITION	REQUIREMENT
6	Connector Mate Force	Mate connector at a rate of 25 ± 6 mm (1 ± ¼ inch) per minute.	22 N (5 lbf) unshielded MAXIMUM insertion force 35 N (8 lbf) shielded MAXIMUM insertion force
7	Durability	Mate connectors up to 750 cycles at a maximum rate of 10 cycles per minute prior to Environmental Tests.	1. 1.2 Ω MAXIMUM 2. show no physical damage 3. LED function not to fail.
8	Vibration (Random)	Amplitude: 1.50mm (.060") peak to peak Sweep: 10-55-10 Hz in one minute Duration: 15 minutes Direction: X, Y,Z axis (45 minutes total)	1. Discontinue \leq 1microsecond 2. 1.2 Ω MAXIMUM

THIS DOCUMENT CONTAINS INFORMATION THAT IS PROPRIETARY TO MOLEX ELECTRONIC TECHNOLOGIES, LLC AND SHOULD NOT BE USED WITHOUT WRITTEN PERMISSION

REVISION DESCRIPTION	OBSOLETE PART NUMBER AS PER PCN 508518			MODULAR JACK WITH LED & INTEGRATED MAGNETICS SMT TYPE			
CHANGE NO.	671087						
REVISED BY	RPRABHUM	DATE	2021/05/26	DOC TYPE	DOC TYPE DESCRIPTION	DOC PART	SERIES
REV APPR BY	GGA	DATE	2021/08/06	PS	PRODUCT SPECIFICATION WORD	001	48074
INITIAL RELEASE				CUSTOMER		DOCUMENT NUMBER	
INITIAL DRWN	FYANG05	DATE	2014/09/25	GENERAL MARKET		PS-48074-006	C
INITIAL APPR	RZHANG	DATE	2015/03/12				

9	Plug Retention Force	Apply an axial pullout force on the plug at a rate of 25 ± 6 mm (1 ± ¼ inch) .	98 N (22 lbf) MINIMUM retention force Test instruction attached at section 8.
10	Shock (Mechanical)	Mate connectors and shock at 50 G Half-sine, 11ms form shocks in the X, Y, Z axis (9 shocks total).	1. Discontinue ≤ 1microsecond 2. 1.2 Ω MAXIMUM
11	Solderability	Dip solder tails into the molten solder (held at 245 ± 5°C) up to 1.0mm from the bottom of the housing for 5 ± 1 second	Solderable area shall have minimum of 95% solder coverage

5.3 ENVIRONMENTAL REQUIREMENTS

ITEM	DESCRIPTION	TEST CONDITION	REQUIREMENT
12	Shock (Thermal)	Mate connectors, expose to 10 cycles of: -40°C to +85°C 30 minutes dwell. Contact resistance test pin pairs: J1 to J2 , J3 to J6;	1. Visual: No Damage 2. 1.2 Ω MAXIMUM on initial, ΔR: 20mΩ Max(change from initial) 3. LED function not to fail.
13	Thermal Aging	Mate connectors; expose to: 48 hours at 85±2°C contact resistance test pin pairs: J1 to J2 , J3 to J6;	1. Visual: No Damage 2. 1.2 Ω MAXIMUM on initial, ΔR: 20mΩ Max(change from initial) 3. LED function not to fail.
14	Humidity (Cyclic)	Mate connectors; expose to 10 cycles at 90-95% relative humidity with temperatures at +25°C and +65°C per MIL-STD-202F method 106F (without -10°C dip) contact resistance test pin pairs: J1 to J2 , J3 to J6;	1. Visual: No Damage 2. 1.2 Ω MAXIMUM on initial, ΔR: 20mΩ Max(change from initial) 3. LED function not to fail.
15	IR Reflow	See appendix "A"	1. Visual: No Damage 2. 1.2 Ω MAXIMUM on initial, ΔR: 20mΩ Max(change from initial) 3. LED function not to fail.
16	Salt Spray	5±1% salt solution Duration 48 hrs	1. Visual: No Damage 2. 1.2 Ω MAXIMUM on initial, ΔR: 20mΩ Max(change from initial) 3. LED function not to fail.

Note:

All tests shall meet visual requirements, show no physical damage and meet requirements of following additional 5.4 tests group. The test group shows the test sequences and shall completely test 5 pcs samples in each group. There are another four test items (Current Temperature Rating, Plug Retention Force, Solderability, IR Reflow) should be done by individual test condition and requirement shown above.

THIS DOCUMENT CONTAINS INFORMATION THAT IS PROPRIETARY TO MOLEX ELECTRONIC TECHNOLOGIES, LLC AND SHOULD NOT BE USED WITHOUT WRITTEN PERMISSION

REVISION DESCRIPTION	OBSOLETE PART NUMBER AS PER PCN 508518			MODULAR JACK WITH LED & INTEGRATED MAGNETICS SMT TYPE			
CHANGE NO.	671087						
REVISED BY	RPRABHUM	DATE	2021/05/26	DOC TYPE	DOC TYPE DESCRIPTION	DOC PART	SERIES
REV APPR BY	GGA	DATE	2021/08/06	PS	PRODUCT SPECIFICATION WORD	001	48074
INITIAL RELEASE				CUSTOMER	DOCUMENT NUMBER	REVISION	SHEET
INITIAL DRWN	FYANG05	DATE	2014/09/25	GENERAL MARKET	PS-48074-006	C	3 OF 7
INITIAL APPR	RZHANG	DATE	2015/03/12				

5.4 TEST GROUP / TEST SEQUENCE

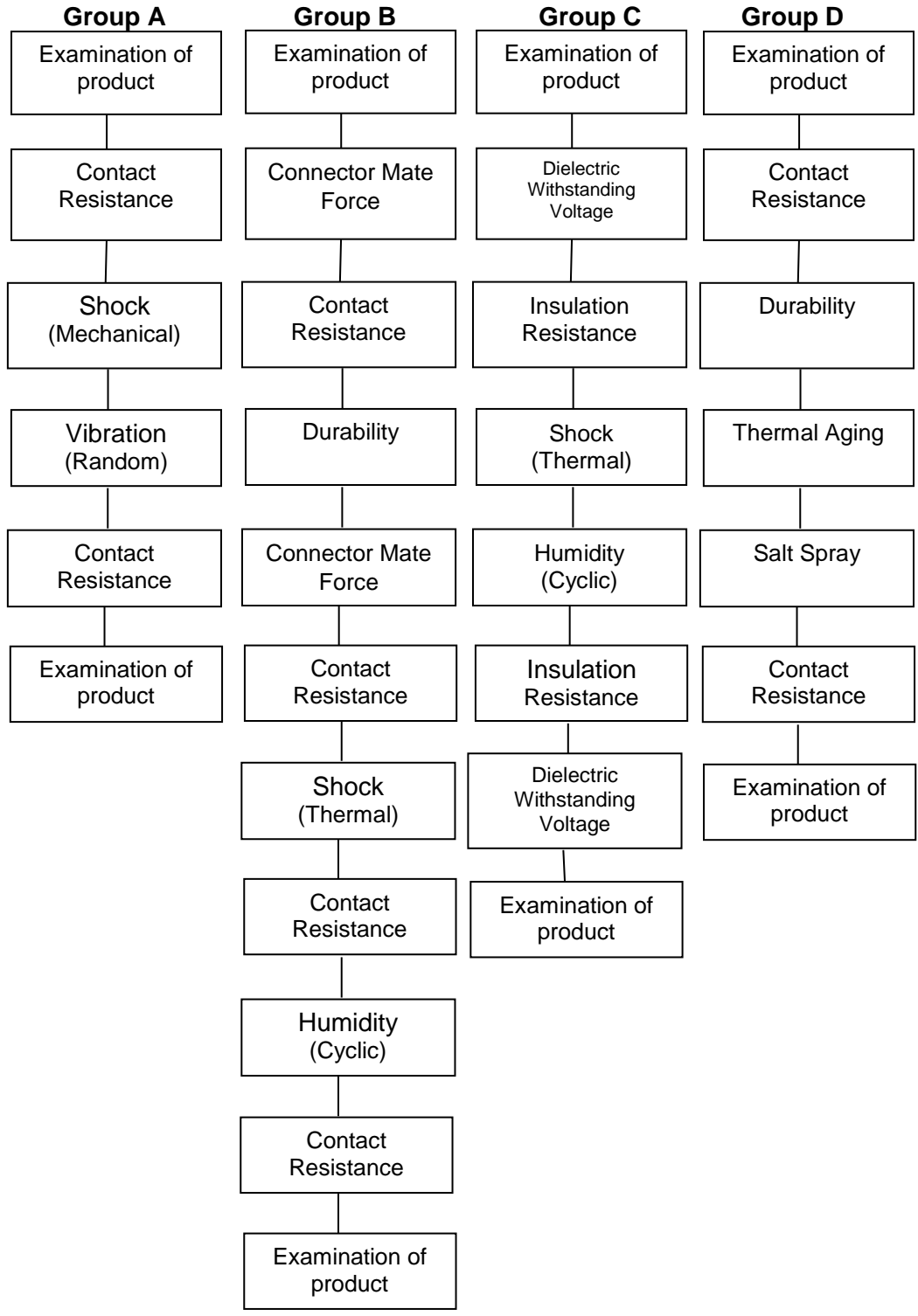

THIS DOCUMENT CONTAINS INFORMATION THAT IS PROPRIETARY TO MOLEX ELECTRONIC TECHNOLOGIES, LLC AND SHOULD NOT BE USED WITHOUT WRITTEN PERMISSION

REVISION DESCRIPTION	OBSOLETE PART NUMBER AS PER PCN 508518			MODULAR JACK WITH LED & INTEGRATED MAGNETICS SMT TYPE			
CHANGE NO.	671087						
REVISED BY	RPRABHUM	DATE	2021/05/26	DOC TYPE	DOC TYPE DESCRIPTION	DOC PART	SERIES
REV APPR BY	GGA	DATE	2021/08/06	PS	PRODUCT SPECIFICATION WORD	001	48074
INITIAL RELEASE				CUSTOMER	DOCUMENT NUMBER	REVISION	SHEET
INITIAL DRWN	FYANG05	DATE	2014/09/25	GENERAL MARKET	PS-48074-006	C	4 OF 7
INITIAL APPR	RZHANG	DATE	2015/03/12				

5.5 APPENDIX “A” (Pls review with Rockwell spec.)

<INFRARED SOLDERING CONDITION>

TEMPERATURE CONDITION GRAPH
TEMPERATURE ON BOARD PATTERN SIDE
TWICE

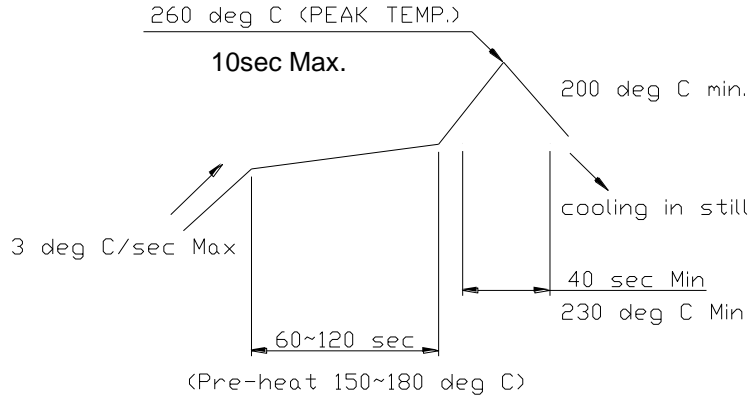

<NOTE>

1. Please check the reflow soldering condition by your own devices beforehand. Because the condition changes by the soldering devices, P.C. Boards, and so on.
2. Thickness of the cream solder shall be maintained 0.12mm MIN. After reflow process.

3. 260°C peak temperature shall last for 10 seconds.

6.0 PACKAGING

Parts shall be packaged to protect against damage during handling, transit and storage. See appropriate sales drawings.

THIS DOCUMENT CONTAINS INFORMATION THAT IS PROPRIETARY TO MOLEX ELECTRONIC TECHNOLOGIES, LLC AND SHOULD NOT BE USED WITHOUT WRITTEN PERMISSION

REVISION DESCRIPTION	OBSOLETE PART NUMBER AS PER PCN 508518			MODULAR JACK WITH LED & INTEGRATED MAGNETICS SMT TYPE			
CHANGE NO.	671087						
REVISED BY	RPRABHUM	DATE	2021/05/26	DOC TYPE	DOC TYPE DESCRIPTION	DOC PART	SERIES
REV APPR BY	GGA	DATE	2021/08/06	PS	PRODUCT SPECIFICATION WORD	001	48074
INITIAL RELEASE				CUSTOMER	DOCUMENT NUMBER	REVISION	SHEET
INITIAL DRWN	FYANG05	DATE	2014/09/25	GENERAL MARKET	PS-48074-006	C	5 OF 7
INITIAL APPR	RZHANG	DATE	2015/03/12				

7.0 SCHEMATIC

Hi-Post Test: 1500 VAC rms (1.5mA cutoff current) for 60 seconds Between Input And Output.
 2250 VDC rms (1.5mA cutoff current) for 60 seconds Between Input And Output.

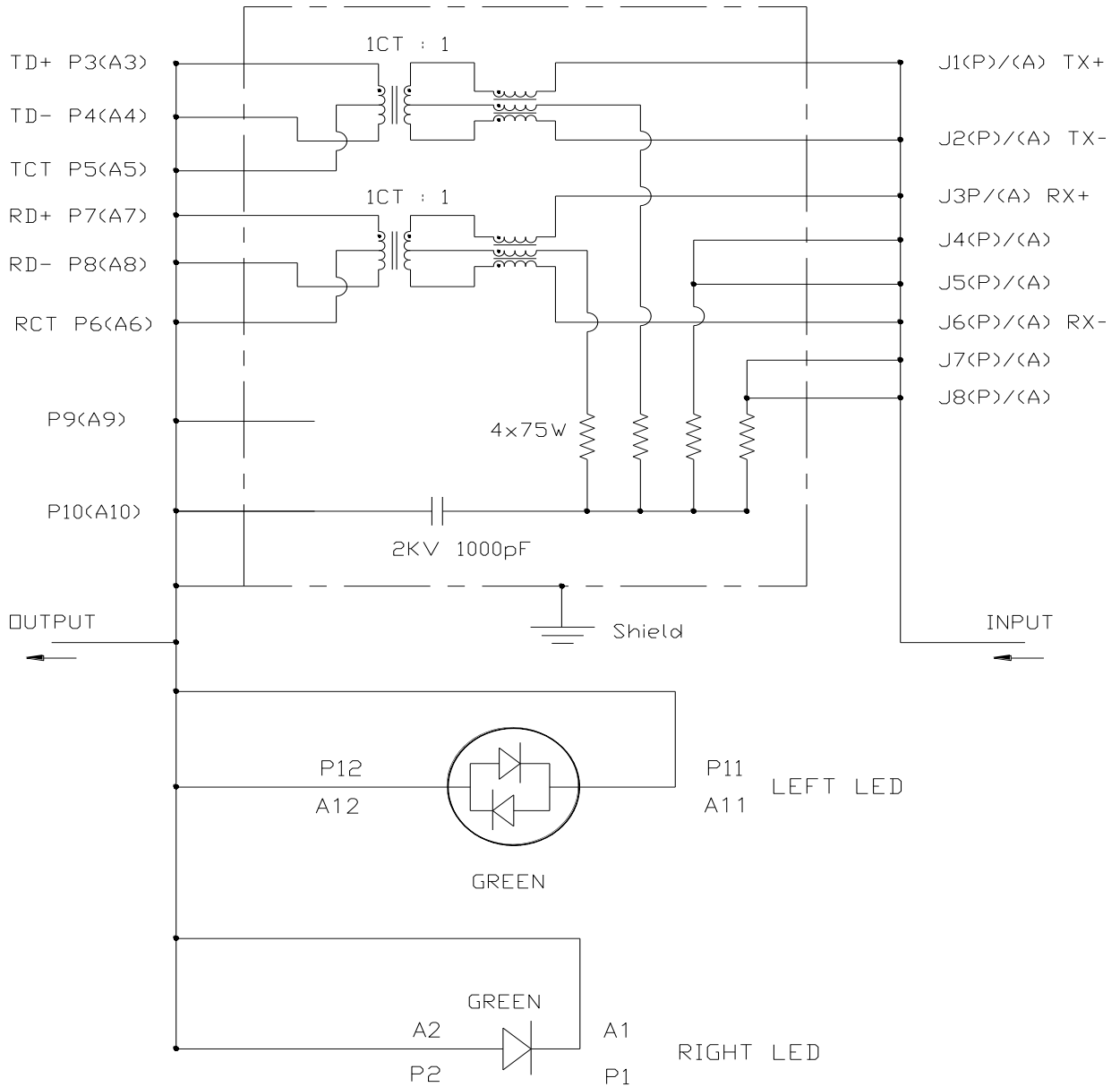

THIS DOCUMENT CONTAINS INFORMATION THAT IS PROPRIETARY TO MOLEX ELECTRONIC TECHNOLOGIES, LLC AND SHOULD NOT BE USED WITHOUT WRITTEN PERMISSION

REVISION DESCRIPTION	OBSOLETE PART NUMBER AS PER PCN 508518			MODULAR JACK WITH LED & INTEGRATED MAGNETICS SMT TYPE					
CHANGE NO.	671087								
REVISED BY	RPRABHUM	DATE	2021/05/26	DOC TYPE	DOC TYPE DESCRIPTION	DOC PART	SERIES		
REV APPR BY	GGA	DATE	2021/08/06	PS	PRODUCT SPECIFICATION WORD	001	48074		
INITIAL RELEASE			CUSTOMER		DOCUMENT NUMBER		REVISION	SHEET	
INITIAL DRWN	FYANG05	DATE	2014/09/25	GENERAL MARKET		PS-48074-006		C	6 OF 7
INITIAL APPR	RZHANG	DATE	2015/03/12						

8.0 OTHER INFORMATION

Plug retention force test instruction

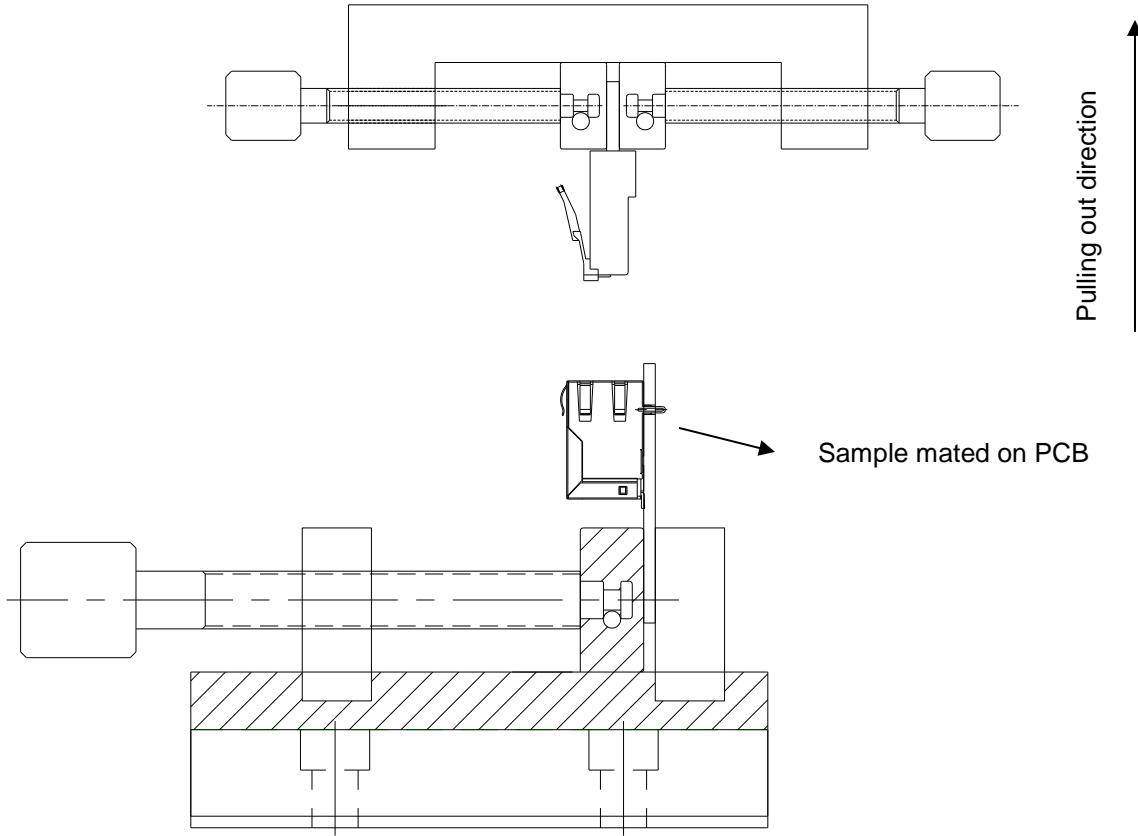

THIS DOCUMENT CONTAINS INFORMATION THAT IS PROPRIETARY TO MOLEX ELECTRONIC TECHNOLOGIES, LLC AND SHOULD NOT BE USED WITHOUT WRITTEN PERMISSION

REVISION DESCRIPTION	OBSOLETE PART NUMBER AS PER PCN 508518			MODULAR JACK WITH LED & INTEGRATED MAGNETICS SMT TYPE			
CHANGE NO.	671087						
REVISED BY	RPRABHUM	DATE	2021/05/26	DOC TYPE	DOC TYPE DESCRIPTION	DOC PART	SERIES
REV APPR BY	GGA	DATE	2021/08/06	PS	PRODUCT SPECIFICATION WORD	001	48074
INITIAL RELEASE				CUSTOMER	DOCUMENT NUMBER	REVISION	SHEET
INITIAL DRWN	FYANG05	DATE	2014/09/25	GENERAL MARKET	PS-48074-006	C	7 OF 7
INITIAL APPR	RZHANG	DATE	2015/03/12				