

STRAIGHT PLUG CRIMP TYPE

R141A.082.161

CABLE 5/50 S

Series : ECO BNC 50

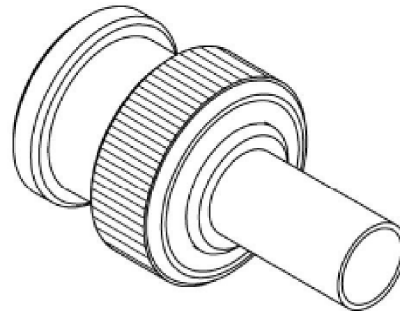
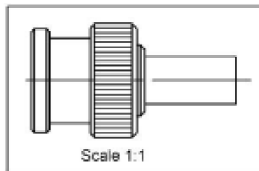
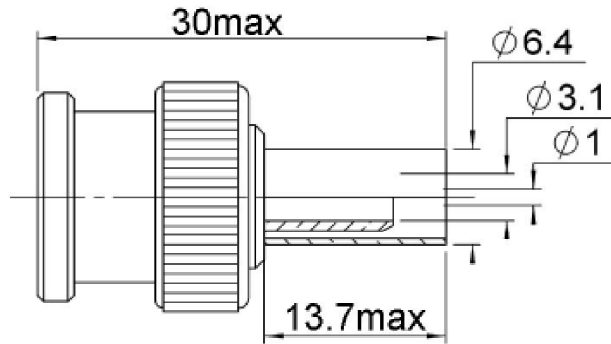

All dimensions are in mm.

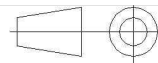

COMPONENTS	MATERIALS	PLATING (μm)
BODY	BRASS	NICKEL
CENTER CONTACT	BRASS	GOLD OVER NICKEL
OUTER CONTACT		
INSULATOR	PTFE	
GASKET		
OTHERS PARTS	BRASS	NICKEL
-	-	-
-	-	-

Issue : 1233 A

In the effort to improve our products, we reserve the right to make changes judged to be necessary.



STRAIGHT PLUG CRIMP TYPE

R141A.082.161

CABLE 5/50 S

Series : **ECO BNC 50**

PACKAGING

Standard	Unit	Other
100	'W' option	Contact us

SPECIFICATION

ELECTRICAL CHARACTERISTICS

Impedance		50 Ω
Frequency		0-1 GHz
VSWR	1.3 +	0,0000 x F(GHz) Maxi
Insertion loss		0.2 √F(GHz) dB Maxi
RF leakage	- (NA - F(GHz)) dB Maxi
Voltage rating		500 Veff Maxi
Dielectric withstanding voltage		1500 Veff mini
Insulation resistance		5000 MΩ mini

CABLE ASSEMBLY

Stripping	a	b	c	d	e	f
mm	4,00	8,50	16,5	0,00	12,5	0,00

Assembly instruction : **Crimp 01**

Recommended cable(s)desnor
RG 58
KX 15

Characteristics indicated on this data sheet are those that can be achieved with the highest performance cable. Intrinsic limitations of the cable may diminish the performance of the assembly

Cable retention

- pull off **90** N mini
- torque **NA** N.cm

MECHANICAL CHARACTERISTICS

Center contact retention		
Axial force – Mating end	10	N mini
Axial force – Opposite end	10	N mini
Torque	NA	N.cm mini

TOOLING

Part Number	Description	Hexagon
R282.293.000	CRIMPING TOOL M22520/5-01	
R282.235.011	CRIMPING DIES M22520/5-11	5.41
R282.223.000	CRIMPING TOOL	5.41

Recommended torque		
Mating	NA	N.cm
Panel nut	NA	N.cm
Clamp nut	NA	N.cm
A/F clamp nut	0,0000	mm

Mating life	100	Cycles mini
Weight	10,3800	g

OTHER CHARACTERISTICS

ENVIRONMENTAL

Operating temperature	-40/+85	° C
Hermetic seal	NA	Atm.cm3/s
Panel leakage	NA	

Issue : **1233 A**

In the effort to improve our products, we reserve the right to make changes judged to be necessary.

