

PAGE 1/3	ISSUE 23-08-17B	SERIES 4.3-10	PART NUMBER R183031017
----------	-----------------	---------------	------------------------

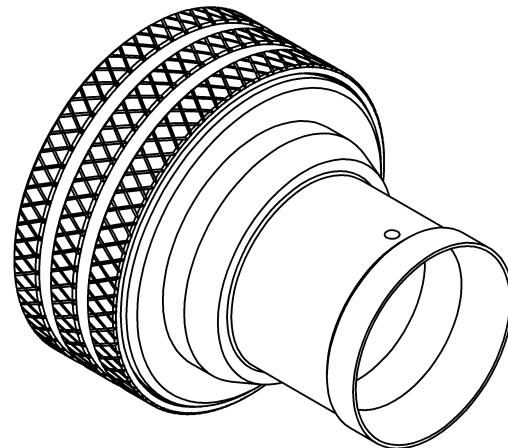

All dimensions are in mm. Tolerances according ISO 2768 m-H

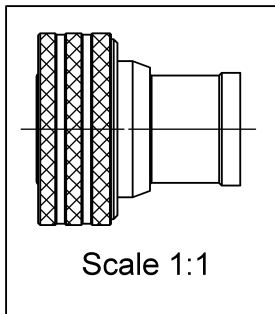
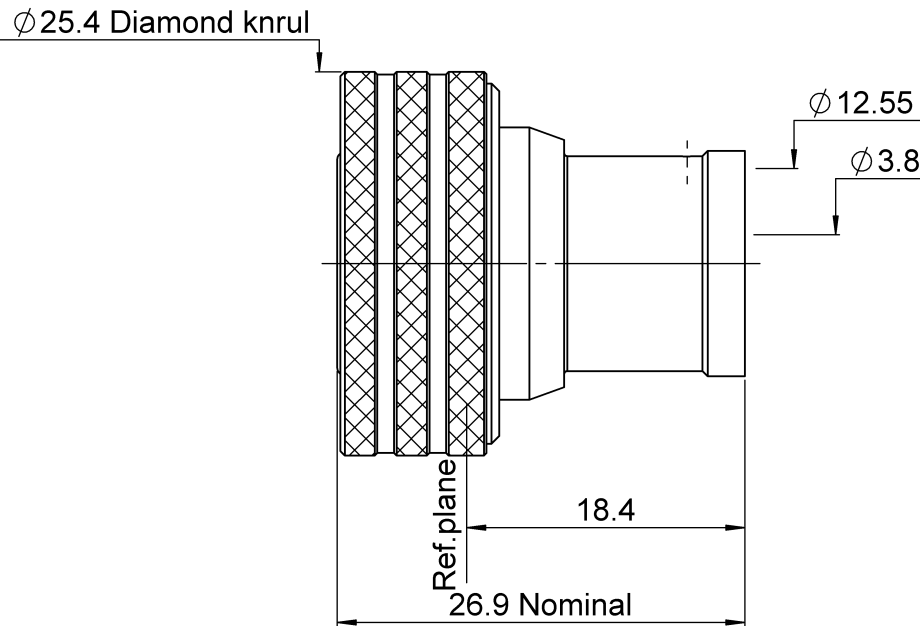
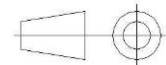

COMPONENTS	MATERIALS	PLATING (μm)
Body	BRASS	BBR
Center contact	BRASS	SILVER
Outer contact		
Insulator	PTFE	
Gasket	EPDM	
Others parts	BRASS	BBR
Retaining ring	STAINLESS STEEL	-
-	-	-

PAGE 2/3	ISSUE 23-08-17B	SERIES 4.3-10	PART NUMBER R183031017
-----------------	------------------------	----------------------	-------------------------------

PACKAGING

Standard	Unit	Other
50	Contact us	Contact us

ELECTRICAL CHARACTERISTICS

Impedance	50	Ω
Frequency	0-6	GHz
VSWR	1.02 + 0.0150	x F(GHz) Maxi
Insertion loss	0.05	√F(GHz) dB Maxi
RF leakage	- (NA)	- F(GHz) dB Maxi
Voltage rating	1000	Veff Maxi
Dielectric withstanding voltage	2500	Veff mini
Insulation resistance	5000	MΩ mini

MECHANICAL CHARACTERISTICS

Center contact retention		
Axial force – Mating End	30	N mini
Axial force – Opposite end	30	N mini
Torque	NA	N.cm mini
Recommended torque		
Mating	NA	N.cm
Panel nut	NA	N.cm
Clamp nut	NA	N.cm
A/F clamp nut	0.0000	mm
Mating life	100	Cycles mini
Weight	31.4680	g

ENVIRONMENTAL

Operating temperature	-55~+90	°C
Hermetic seal	NA	Atm.cm3/s
Panel leakage	NA	

SPECIFICATION

CABLE ASSEMBLY

Stripping	a	b	c	d	e	f
mm	7	15	0	0	0	0

Assembly instruction: **see page3**

Recommended cable(s)

FSJ4RN-50B
HCF1/2"CuH-50oAICu

Characteristics indicated on this data sheet are those that can be achieved with the highest performance cable. Intrinsic limitations of the cable may diminish the performance of the assembly

Cable retention

- pull off	350	N mini
- torque	NA	N.cm

TOOLING

Part Number	Description	Hexagon
.	.	.

OTHER CHARACTERISTICS

IP 67 mated condition
PIM3<=-123 dBm, 2 carriers of +43dBm

PAGE 3/3	ISSUE 23-08-17B	SERIES 4.3-10	PART NUMBER R183031017
----------	-----------------	---------------	------------------------

COMPONENTS

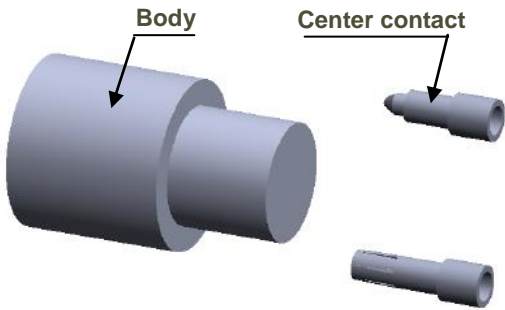

STRIPPING DIMENSION

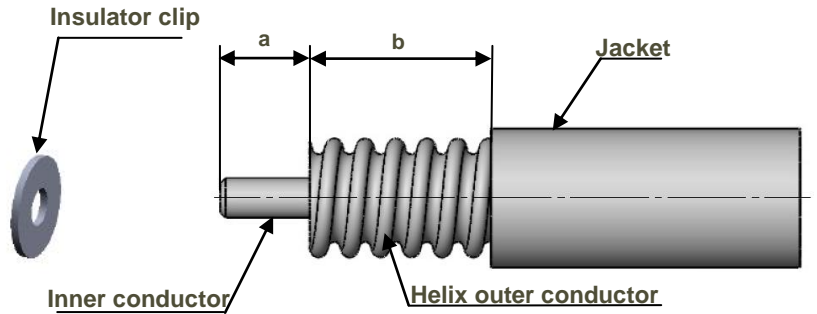

1

- Strip the cable.
- Do not damage the outer conductor.
- The end surface of inner conductor should be chamfered.
- Remove impurities such as copper scraps and burrs on the end surface of the cable.

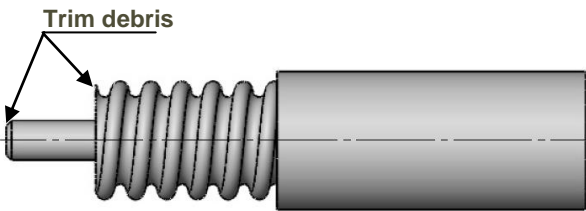

3

- Push the cable into the connector body, until it stops.
- Use the reserved solder wire to wrap the cable to fill the space between cable and connector.
- Solder the connector body with cable.

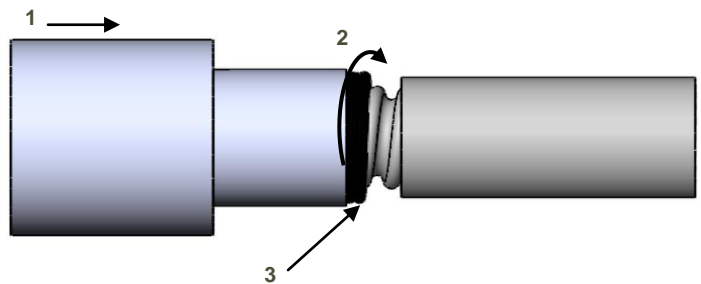

2

- Insert insulator clip on the cable.
- Insert center contact until the insulator clip.
- Solder center contact.
- Wrap the cable by solder wire (Dia 1.2mm).

