

**STRAIGHT BULKHEAD JACK PANEL SEAL**  
**SOLDER TYPE - CABLE .141**

**R124.325.003**  
**SERIES SMA-COM**

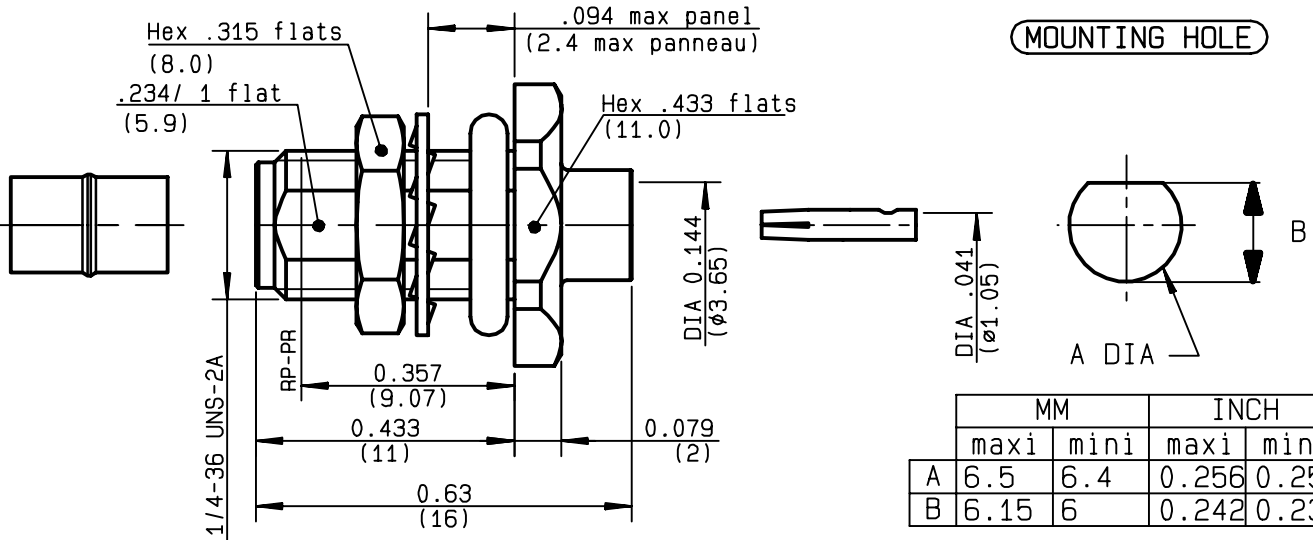

	MM		INCH	
	maxi	mini	maxi	mini
A	6.5	6.4	0.256	0.252
B	6.15	6	0.242	0.236

NOMINAL IMPEDANCE	<b>50</b> Ω
FREQUENCY RANGE	<b>0-18</b> GHz
TEMPERATURE RATING	<b>-65/+105</b> °C
V.S.W.R	<b>1.05</b> + <b>.01</b> x F(GHz)Maxi
RF INSERTION LOSS	<b>0.05</b> √F(GHz) dB Maxi
VOLTAGE RATING	<b>500</b> Veff Maxi
DIELECTRIC WITHSTANDING VOLTAGE	<b>1000</b> Veff Mini
INSULATION RESISTANCE	<b>5000</b> MΩMini
HERMETIC SEAL	<b>NA</b> Atm.cm <sup>3</sup> /s
LEAKAGE (pressurized only)	<b>NA</b>
MECHANICAL DURABILITY	<b>100</b> Cycles
WEIGHT	<b>3.6</b> gr
SPECIFICATION	

CABLES : <b>KS 2</b> <b>RG 402</b>	
OTHERS CHARACTERISTICS	
CABLE RETENTION	<b>270</b> N Mini
CENTER CONTACT RETENTION	
Axial force - mating end	<b>NA</b> N Mini
Axial force - opposite end	<b>NA</b> N Mini
Torque	<b>NA</b> cm.N Mini
RECOMMENDED TORQUES	
Mating	<b>NA</b> cm.N
Panel nut	<b>150</b> cm.N
Clamp nut	<b>NA</b> cm.N

CONNECTOR PARTS	MATERIALS	FINISH	(all values are given ) in micrometers
BODY	BRASS	GOLD 0.2 OVER NICKEL 2	
OUTER CONTACT			
CENTER CONTACT	BERYLLIUM COPPER	GOLD 1.3 OVER COPPER 2.5	
INSULATOR	PTFE	-	
GASKET	SILICONE RUBBER	-	
OTHERS PIECES	BRASS	GOLD 0.2 OVER NICKEL 2	

ISSUE	CREATION DATE	FILE PART-NUMBER
<b>9847C00</b>	<b>23/09/1996</b>	<b>96-1200-090</b>



PERRIN

The information given here is subject to change without notice.  
Design changes may be in order to improve the product .

*Connect to the future*



**R124.325.003**

ISSUE **9847C00** SERIES **SMA-COM**

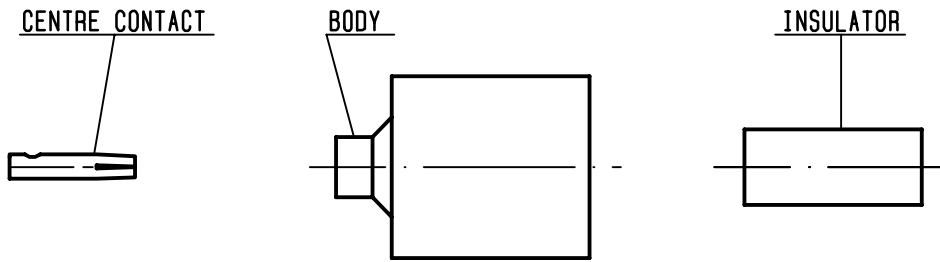

①

Take the tool kit : R282.120.000  
Strip the dielectric of the cable .  
Stripping tool cable : R282.053.000  
Trimmer : R282.067.000  
Clean the cable .  
-

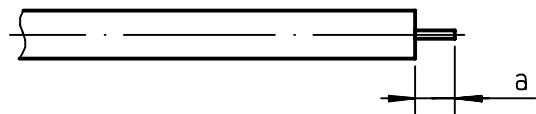

Stripping	a	b	c	d	e
inch	0.125 0	0	0	0	0
mm	3.17				

②

Screw the positioner R282.744.220 onto the soldering jig R282.740.000  
Slide contact into positioner .  
Insert solder gauge R282.862.060 between contact and cable .  
Tighten and solder the contact .

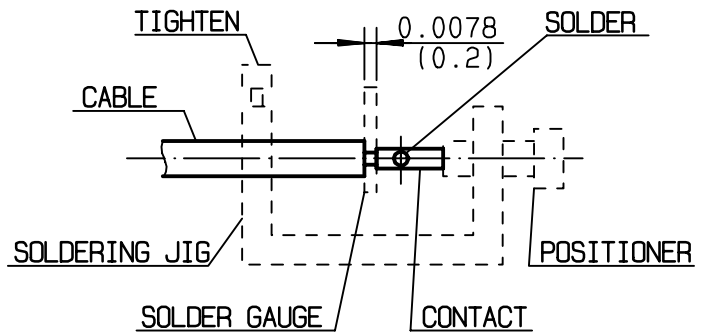

③

After cooling remove cable assembly from the jig .  
Screw positioner R282.744.011 into the connector .  
Slide cable into the connector until it bottoms againsts positioner R282.744.011 .  
Tighten .  
Put 3 rings of solder around the cable and solder .

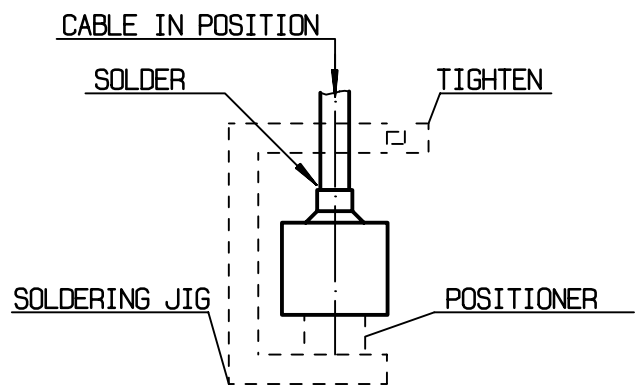

④

After cooling remove cable assembly from the jig .  
Screw positioner cut R282.914.010  
Cut the dielectric flush to clamp braid sleeve with tool R282.915.010.  
Screw female dielectric insert tool onto connector and insert insulator with the dielectric plunger R282.730.043

