

PANEL CUT OUT

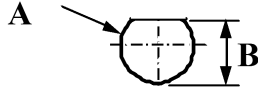

inches		
	Maxi	mini
A	.198	.192
B	.183	.177

REVISIONS			
REV.	DESCRIPTION	DATE	APPROVED
A	INITIAL RELEASE	04/18/18	C.E.

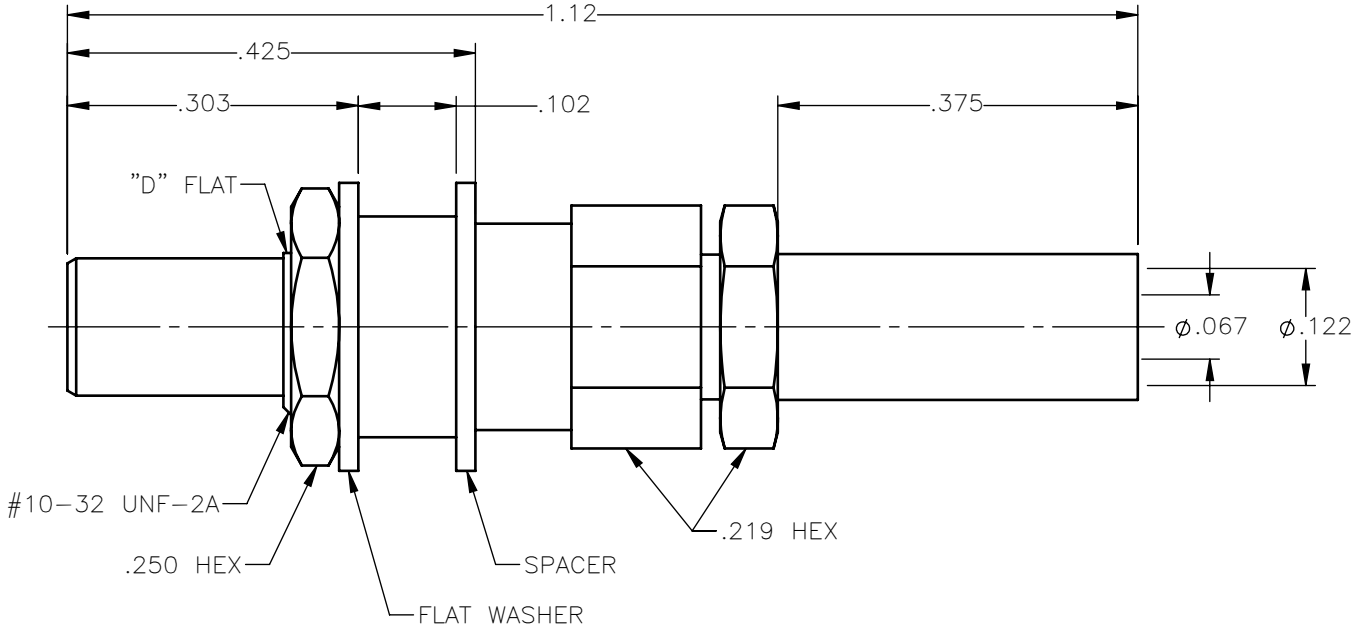



NOTES:

MATERIALS:

1. INSULATORS = VIRGIN WHITE TEFLON PER ASTM D1710, GRADE 1, TYPE I, CLASS "B".
2. CRIMP SLEEVE = SEAMLESS LOWLEAD BRASS TUBE, ALLOY 330, SOFT ANNEAL TEMPER, .025/.060 GRAIN SIZE OR SEAMLESS COPPER TUBE PER ASTM B75, TYPE C12000, TEMPER: LIGHT ANNEAL O50 EXCEPT YIELD STRENGTH.
3. ALL OTHER METAL PARTS = BRASS PER ASTM B16, ALLOY C36000, TEMPER H02.

FINISHES:

1. CONTACT = GOLD PLATE PER ASTM B488-11, TYPE II, 50 μ in MIN, GRADE C, OVER 100 TO 200 μ in STRESS FREE SULFAMATE NICKEL PER AMS-QQ-N-290.
2. ALL OTHER METAL PARTS = NICKEL PLATE PER AMS-QQ-N-290, CLASS 1, GRADE G, EXCEPT 100 TO 200 μ in THICK OVER 50 TO 100 μ in THICK COPPER PER AMS 2418.

UNLESS OTHERWISE SPECIFIED DIMENSIONS ARE IN INCHES TOLERANCES ON	DWN: C.E.	DATE: 04/18/18	 Property of Radiall This document cannot be reproduced or communicated to a third party without prior written permission of RADIALL.	
	CHKD: D.N.	DATE: 04/18/18		
DECIMAL	ANGLE	APVD: J.M.	SLB STRAIGHT MALE JACK BULKHEAD MOUNT CRIMP TYPE FOR .086 S/R & SIMILAR CABLES	
REFERENCE:	MATERIALS & FINISHES:	SIZE: A	FSCM NO.: 19505	DWG NO.: 3003-7571-703
ORIGINATED: C.E. DATE: 04/18/18	SEE NOTES	SCALE: 5:1	THIRD ANGLE PROJECTION	REV: A
			SHEET 1 OF 1	

3003-7571-703