

PAGE 1/3	ISSUE 24-08-18D	SERIES TNC	PART NUMBER R143092790
----------	-----------------	------------	------------------------

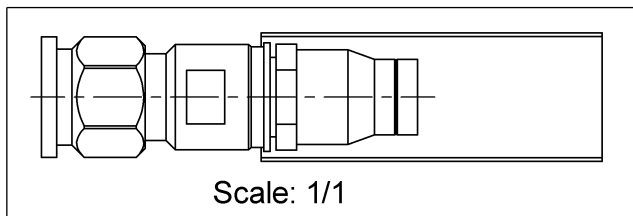

All dimensions are in mm.

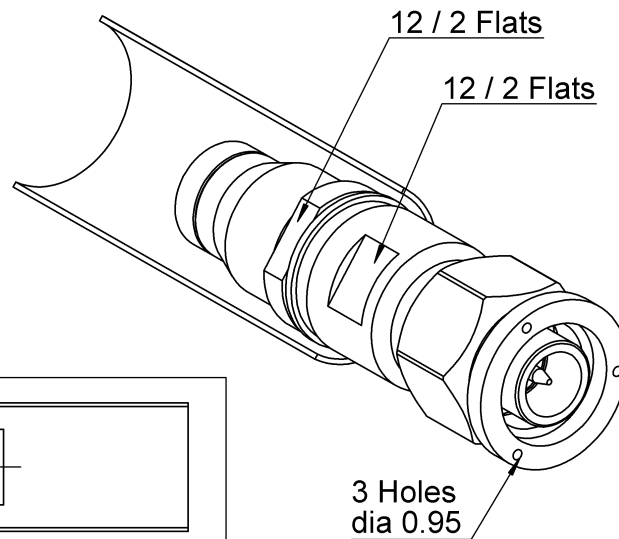
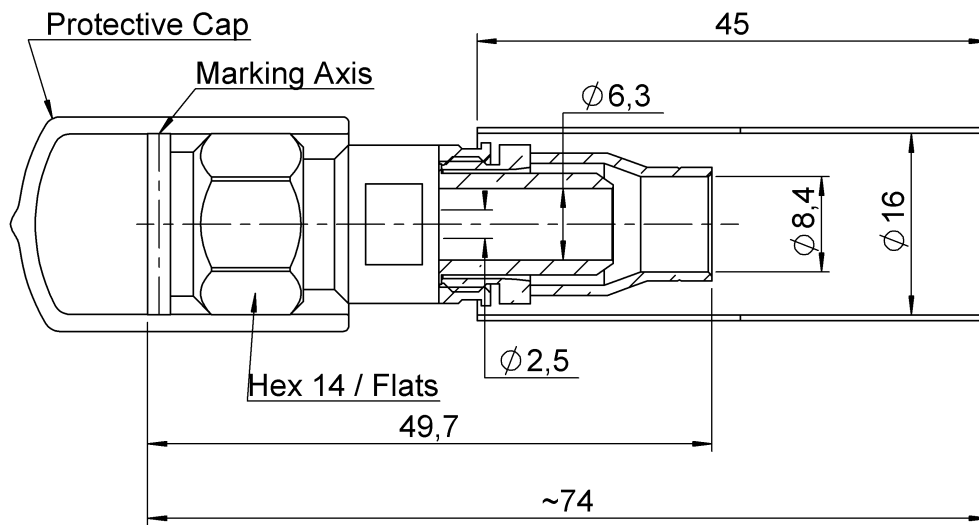
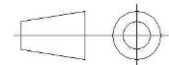

COMPONENTS	MATERIALS	PLATING (µm)
Body	STAINLESS STEEL.	PASSIVATED
Center contact	BRASS	GOLD 0.5 OVER NICKEL 2
Outer contact		
Insulator	PTFE	
Gasket	SILICONE RUBBER	
Others parts	BRASS	NICKEL 2
-	-	-
-	-	-

PAGE 2/3	ISSUE 24-08-18D	SERIES TNC	PART NUMBER R143092790
-----------------	------------------------	-------------------	-------------------------------

PACKAGING

Standard	Unit	Other
1	Contact us	Contact us

ELECTRICAL CHARACTERISTICS

Impedance	50	Ω
Frequency	0-6	GHz
VSWR	1.2 + 0,0000	x F(GHz) Maxi
Insertion loss	0.06	√F(GHz) dB Maxi
RF leakage	- (57*)	- F(GHz)) dB Maxi
Voltage rating	500	Veff Maxi
Dielectric withstanding voltage	1500	Veff mini
Insulation resistance	5000	MΩ mini

MECHANICAL CHARACTERISTICS

Center contact retention		
Axial force – Mating End	27	N mini
Axial force – Opposite end	27	N mini
Torque	NA	N.cm mini
Recommended torque		
Mating	265	N.cm
Panel nut	NA	N.cm
Clamp nut	370	N.cm
A/F clamp nut	12,0000	mm
Mating life	500	Cycles mini
Weight	33,2000	g

ENVIRONMENTAL

Operating temperature	-65/+165	°C
Hermetic seal	NA	Atm.cm3/s
Panel leakage	NA	

SPECIFICATION

**ASNE0461-F02 - -
QAE 06-02**

CABLE ASSEMBLY

Stripping	a	b	c	d	e	f
mm	9	9	27	0	0	0

Assembly instruction:

Recommended cable(s)

**ASNE0406-WD
ASNE0692-WN**

Characteristics indicated on this data sheet are those that can be achieved with the highest performance cable. Intrinsic limitations of the cable may diminish the performance of the assembly

Cable retention

- pull off	400	N mini
- torque		N.cm

TOOLING

Part Number	Description	Hexagon
282247	CRIMPING DIE M 22520/5-61	10.9
282291	CRIMPING TOOL M22520/1-01	2x4 (loc 8)
282997	POSITIONER FOR TOOL 282.291(M22520/1-13)	Red
R282293000	CRIMPING TOOL M22520/5-01	

OTHER CHARACTERISTICS

* up to 3 GHz
General stripping tolerances+/-0.1mm

PAGE 3/3	ISSUE 24-08-18D	SERIES TNC	PART NUMBER R143092790
----------	-----------------	------------	------------------------

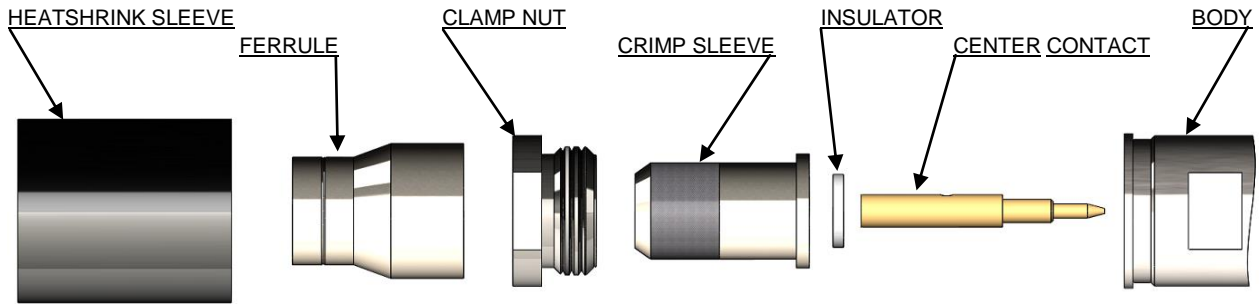

1

Slide onto the cable the heatshrink sleeve and the ferrule. Strip the cable.
Optionally, to facilitate the stripping of the inner cable, the length "a" could be stripped after crimping of the ferrule.

2

Slide the clamp nut onto the crimp sleeve.
Slide sub-assembly under the braid.
(for the WN cable cut the foil under the braid)
Slide ferrule over the braid against clamp nut. (In direction F)
Crimp the ferrule with crimping tool (R282293000) + dies (282247).

3

The dielectric must be in the same plane as the face of the crimp sleeve. Cut the dielectric flush to crimp sleeve if it exceeds. Clean the dielectric side.
Mount insulator against crimp sleeve.

4

Slide the center contact onto the cable inner conductor against insulator.
Crimp the center contact with the crimping tool (282291) and the positioner (282997).

5

Screw sub-assembly into the connector body.
(recommended coupling see the connector TDS)
Slide sleeve heatshrink over ferrule and put in the place as below