

REVISIONS			
REV.	DESCRIPTION	DATE	APPROVED
A	INITIAL RELEASE	03/05/18	C.E.

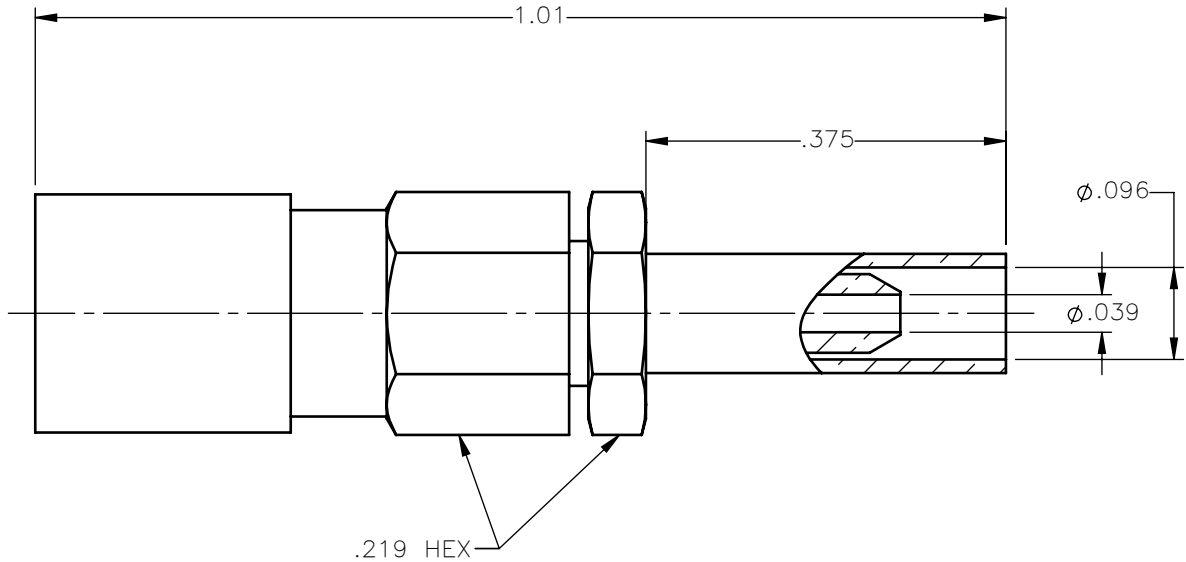

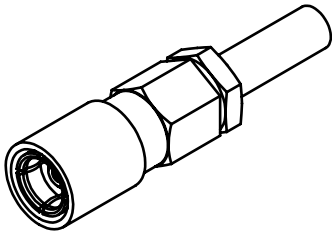

NOTES:

MATERIALS:

1. BODY & CRIMP NUT = BRASS PER ASTM B16, ALLOY C36000, TEMPER H02.
2. INSULATORS = VIRGIN WHITE TEFLON PER ASTM D1710, GRADE 1, TYPE I, CLASS "B".
3. CONTACT & SPRING = BERYLLIUM COPPER PER ASTM B196, ALLOY C17300, TEMPER TD04.
4. CRIMP SLEEVE = SEAMLESS LOWLEAD BRASS TUBE, ALLOY 330, SOFT ANNEAL TEMPER, .025/.060 GRAIN SIZE OR SEAMLESS COPPER TUBE PER ASTM B75, TYPE C12000, TEMPER: LIGHT ANNEAL O50 EXCEPT YIELD STRENGTH.
5. SLEEVE = BRASS PER C36000, ANNEALING 1H AT 500°C, HARDNESS 80-120 HV.

FINISHES

1. CONTACT = GOLD PLATE PER ASTM B488-11, TYPE II, 50µin MIN, GRADE C, OVER 100 TO 200µin STRESS FREE SULFAMATE NICKEL PER AMS-QQ-N-290.
2. ALL OTHER METAL PARTS = NICKEL PLATE PER AMS-QQ-N-290, CLASS 1, GRADE G, EXCEPT 100 TO 200µin THICK OVER 50 TO 100µin THICK COPPER PER AMS 2418.

UNLESS OTHERWISE SPECIFIED DIMENSIONS ARE IN INCHES TOLERANCES ON	DWN: C.E.	DATE: 03/05/18	 Property of Radiall This document cannot be reproduced or communicated to a third party without prior written permission of RADIALL.		
	CHKD: D.N.	DATE: 03/05/18			
DECIMAL	ANGLE	APVD: J.M.	DATE: 03/05/18	SMB STRAIGHT FEMALE PLUG CRIMP TYPE FOR RG-178 & SIMILAR CABLES	
REFERENCE:	MATERIALS & FINISHES:	SIZE: A	FSCM NO.: 19505		DWG NO.: 2002-7571-002
ORIGINATED: C.E. DATE: 03/05/18	SEE NOTES:	SCALE: 5:1	THIRD ANGLE PROJECTION		REV: A
				SHEET 1 OF 1	

2002-7571-002