

STRAIGHT SQUARE FLANGE JACK
CRIMP AND SOLDER TYPE - CABLE 2.6/50 S

R125.272.000

Series : SMA

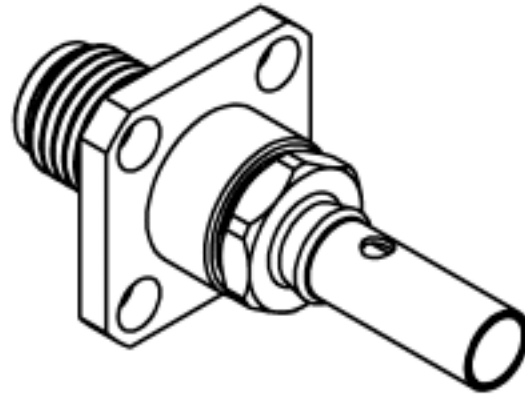
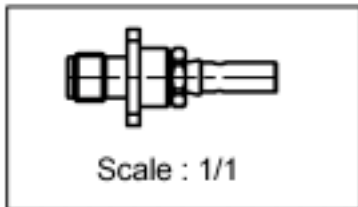
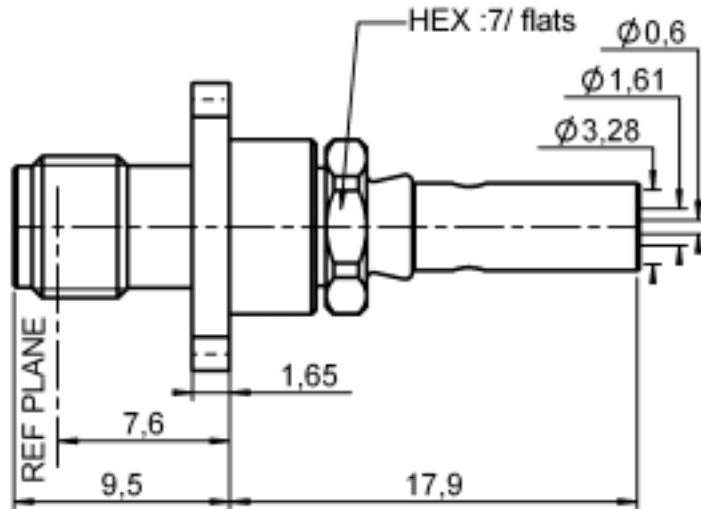
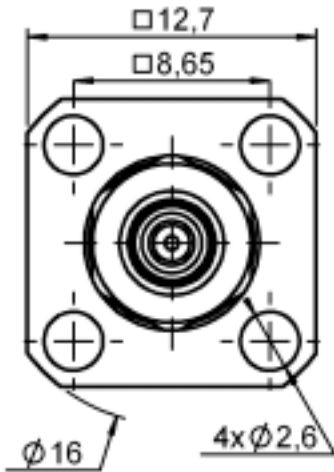

PANEL CUT OUT

mm		
	Maxi	mini
A	6.6	6.5
B	2.7	2.6
C	8.69	8.59

All dimensions are in mm.



COMPONENTS	MATERIALS	PLATINGS (µm)
BODY	STAINLESS STEEL	GOLD 0.5 OVER NICKEL 2
CENTER CONTACT	BERYLLIUM COPPER	GOLD 1.3 OVER NICKEL 2
OUTER CONTACT	-	-
INSULATOR	PTFE	-
GASKET	-	-
OTHERS PARTS	BRASS	GOLD 0.2 OVER NICKEL 2
-	-	-
-	-	-

Issue : 0048 P

In the effort to improve our products, we reserve the right to make changes judged to be necessary.



STRAIGHT SQUARE FLANGE JACK

R125.272.000

CRIMP AND SOLDER TYPE - CABLE 2.6/50 S

Series : SMA

PACKAGING

Standard	Unit	Other
100	'W' option	Contact us

SPECIFICATION

ELECTRICAL CHARACTERISTICS

Impedance		50 Ω
Frequency		0-12.4 GHz
VSWR	1.15 +	0.020 x F(GHz) Maxi
Insertion loss		0.06 √F(GHz) dB Maxi
RF leakage	- (60 - F(GHz)) dB Maxi
Voltage rating		250 Veff Maxi
Dielectric withstanding voltage		750 Veff mini
Insulation resistance		5000 MΩ mini

CABLE ASSEMBLY

Stripping	a	b	c	d	e	f
mm	2.85	7.00	18.0	0.00	8.15	0.00

Assembly instruction :

Recommended cable(s)

RG 316
 RG 188
 KX 22A
 RG 174
 KX 3B
 RG 174 FTX
 -
 -
 SHF 2.7T U

Cable retention

- pull off **90** N mini
 - torque **NA** N.cm

MECHANICAL CHARACTERISTICS

Center contact retention		
Axial force – Mating end		27 N mini
Axial force – Opposite end		NA N mini
Torque		NA N.cm mini

Recommended torque		
Mating		NA N.cm
Panel nut		NA N.cm
Clamp nut		100 N.cm
A/F clamp nut		7.000 mm

Mating life		500 Cycles mini
Weight		5.200 g

TOOLING

Part Number	Description	Hexagon
.	.	.
R282.235.003	CRIMPING DIES	3.25
R282.211.000	CRIMPING TOOL	3.25
R282.293.000	CRIMPING TOOL	-

OTHERS CHARACTERISTICS

-

ENVIRONMENTAL

Operating temperature		-65/+165 °C
Hermetic seal		NA Atm.cm3/s
Panel leakage		NA

Issue : 0048 P

In the effort to improve our products, we reserve the right to make changes judged to be necessary.



STRAIGHT SQUARE FLANGE JACK
CRIMP AND SOLDER TYPE - CABLE 2.6/50 S

R125.272.000

Series : SMA

COMPONENTS

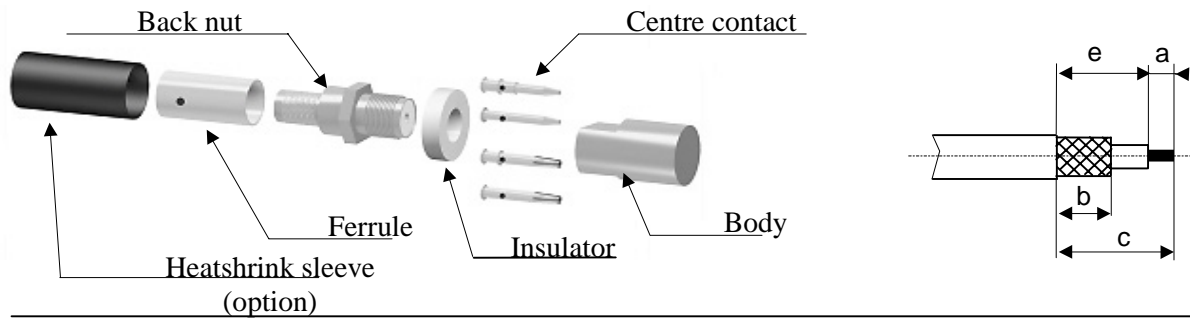

1

Slide the heatshrink sleeve onto the cable (Option).
 Slide the ferrule onto the cable.
 Position the ferrule's hole at the front if soldering.
 Position the ferrule's hole at the back if crimping.
 Strip the cable.

4

Slide the centre contact on until it bottoms against the insulator back nut.
 Solder or crimp the contact (see connector TDS).

2

Fan the braid.
 Slide the cable into the back nut.

5

Screw the back nut into the connector body with the adapted wrench.
 Recommended coupling torque (see connector TDS)

3

Slide the ferrule over the braid.
 Crimp the ferrule with crimping tool (see connector TDS).

6

Slide the sleeve over the ferrule and heatshrink it in place (option).

Issue : 0048 P

In the effort to improve our products, we reserve the right to make changes judged to be necessary.

