

**STRAIGHT BULKHEAD JACK PANEL SEAL**

**R164.635.002**

**REAR MOUNTING SOLDER TYPE .141**

Series : QN

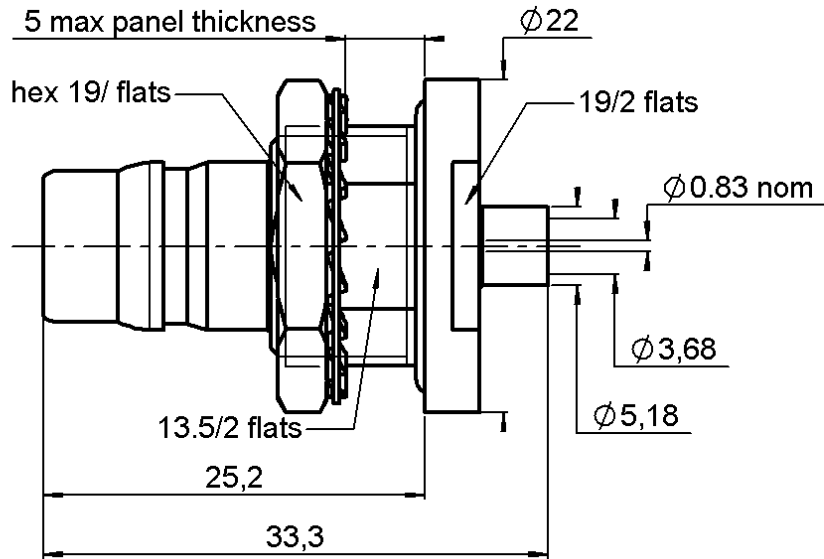

**PANEL CUT OUT**

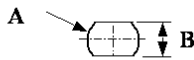

		mm	
		Maxi	mini
A		16.3	16
B		13.9	13.6

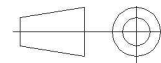
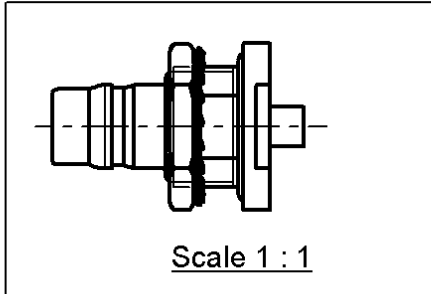
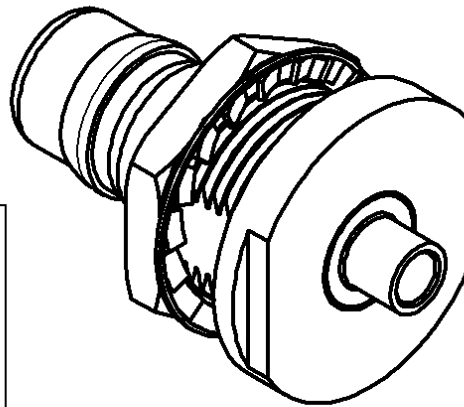

All dimensions are in mm.

COMPONENTS	MATERIALS	PLATINGS (µm)
BODY	BRASS	BBR 0.5 OVER SILVER 3
CENTER CONTACT	BERYLLIUM COPPER	GOLD 1.3 OVER COPPER 2.5
OUTER CONTACT		-
INSULATOR	PTFE	
GASKET	SILICONE RUBBER	
OTHERS PARTS	BRASS	GOLD 1 OVER COPPER 2
-	-	-
-	-	-

Issue : 0420 B

In the effort to improve our products, we reserve the right to make changes judged to be necessary.



**STRAIGHT BULKHEAD JACK PANEL SEAL**

**R164.635.002**

**REAR MOUNTING SOLDER TYPE .141**

Series : QN

**PACKAGING**

Standard	Unit	Other
<b>50</b>	<b>'W' option</b>	<b>Contact us</b>

**SPECIFICATION**

**ELECTRICAL CHARACTERISTICS**

Impedance		<b>50</b> Ω
Frequency		<b>0-6*</b> GHz
VSWR	<b>1.05</b> +	<b>0.025</b> x F(GHz) Maxi
Insertion loss		<b>0.048</b> √F(GHz) dB Maxi
RF leakage	- (	<b>**90</b> - F(GHz)) dB Maxi
Voltage rating		<b>350</b> Veff Maxi
Dielectric withstanding voltage		<b>1000</b> Veff mini
Insulation resistance		<b>5000</b> MΩ mini

**CABLE ASSEMBLY**

Stripping	a	b	c	d	e	f
mm	3.17	0.00	0.00	0.00	0.00	0.00

Assembly instruction : **NA**

Recommended cable(s)  
 RG 402  
 KS 2  
 BELN YQ43858  
 HC80000-3

Cable retention  
 - pull off **270** N mini  
 - torque **NA** N.cm

**MECHANICAL CHARACTERISTICS**

Center contact retention		
Axial force – Mating end	<b>27</b>	N mini
Axial force – Opposite end	<b>27</b>	N mini
Torque	<b>NA</b>	N.cm mini

**TOOLING**

Part Number	Description	Hexagon
.	.	.
R282.053.000	STRIPPING TOOL	
R282.067.000	POINTER GAUGE	

Recommended torque		
Mating	<b>NA</b>	N.cm
Panel nut	<b>500</b>	N.cm
Clamp nut	<b>NA</b>	N.cm
A/F clamp nut	<b>19.000</b>	mm

Mating life	<b>100</b>	Cycles mini
Weight	<b>29.500</b>	g

**OTHERS CHARACTERISTICS**

\* usable 0-11GHz  
 \*\* RF Leakage : -80dB min 3<F<6GHz  
 \*\*\* PIM3 : -112 dbm (2x20W at 1.8GHz)  
 IP68

**ENVIRONMENTAL**

Operating temperature	<b>-55/+125</b>	° C
Hermetic seal	<b>NA</b>	Atm.cm3/s
Panel leakage	<b>RUISS</b>	

Issue : 0420 B

In the effort to improve our products, we reserve the right to make changes judged to be necessary.



**STRAIGHT BULKHEAD JACK PANEL SEAL**  
**REAR MOUNTING SOLDER TYPE .141**

**R164.635.002**

Series : QN

**COMPONENTS**

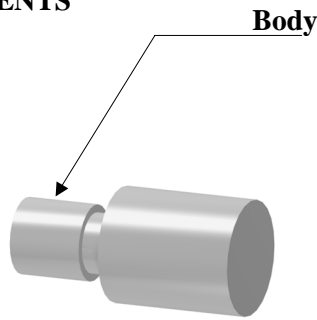

**STRIPPING DIMENSIONS**

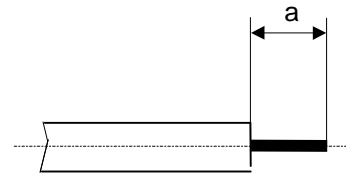

We recommend a thermal preconditioning of the cable

**1**

Insert the cable into the clamp element.  
 Present the pointer in front of the clamp element.  
 Push the cable until it stops, while holding the clamp element pushed on the hollow part of the pointer.  
 Turn the clamp element until the release of the pointer.

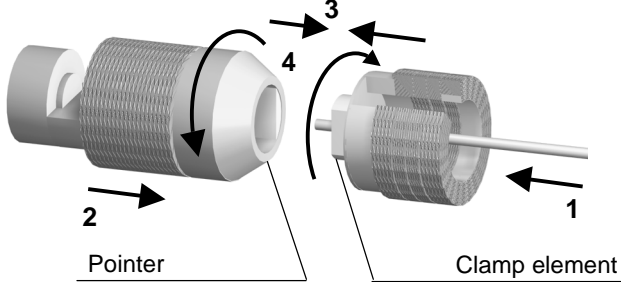

**3**

Position the connector onto the Assembly jig.  
 Slide the cable into the connector until it bottoms against the body tighten.  
 Put three rings of solder around the cable and solder.  
 After cooling, remove the assembly from the jig.

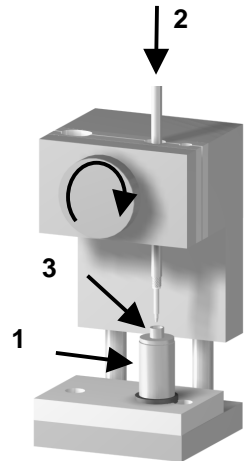

**2**

Present the cutting element in front of the clamp element.  
 Push and turn both elements, back part opposite to the front part. Once they reach the stop, pull without revolving.

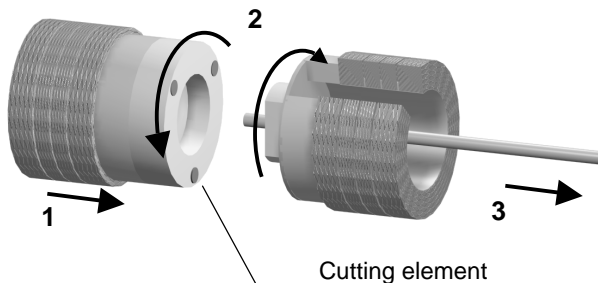

Issue : 0420 B

In the effort to improve our products, we reserve the right to make changes judged to be necessary.



**RADIALL**®