



The Future of Analog IC Technology®

# EV5022C-QV-00A

## 16V, 15A, 3mΩ R<sub>DS\_ON</sub> Hot Swap Protection Device With Current Monitoring

### DESCRIPTION

The MP5022C is a hot-swap protection device designed to protect circuitry on its output from transients on its input. It also protects its input from undesired shorts and transients coming from its output.

An internal charge pump drives the gate of the power device, allowing for a power FET with a very low ON resistance of 3mΩ. The MP5022C includes an optional discharge function that provides a discharge path for the external output capacitor when the part is disabled. Fault protection includes current limit, thermal shutdown and damaged MOSFET detection. The device also features over-voltage protection and under-voltage protection

The MP5022C is available in 3mmx5mm QFN package.

### ELECTRICAL SPECIFICATIONS

Parameter	Symbol	Value	Units
Input Voltage Range	V <sub>IN</sub>	12	V
Output Voltage	V <sub>OUT</sub>	12	V
Load Max	I <sub>OUT</sub>	15	A

### FEATURES

- 4.5V to 16V Operating Input Range
- Integrated 3mΩ Power FET
- Adjustable Current Limit
- Output Current Measurement
- +/-3% Current Limit and Monitor Accuracy
- Fast Response(<200ns) for Short Protection
- PG Detector and FLT B Indication
- PG Assert Low at VIN=0
- Damaged MOSFET Detection
- External Soft Start
- Programmable EN Blanking Time
- Under/Over Voltage Lockout
- Thermal Protection
- Small 3mmx5mm QFN Package

### APPLICATIONS

- Hot Swap
- PC Cards
- Disk Drives
- Servers
- Networking
- Laptops

All MPS parts are lead-free, halogen free, and adhere to the RoHS directive. For MPS green status, please visit MPS website under Quality Assurance.

"MPS" and "The Future of Analog IC Technology" are Registered Trademarks of Monolithic Power Systems, Inc.

## EV5022C-QV-00A EVALUATION BOARD

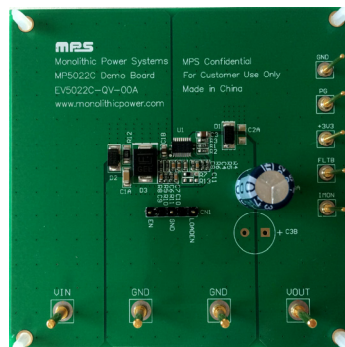

(L x W x H) 8.55cm x 8.55cm x 1.6mm

Board Number	MPS IC Number
EV5022C-QV-00A	MP5022CGQV

### EVALUATION BOARD SCHEMATIC

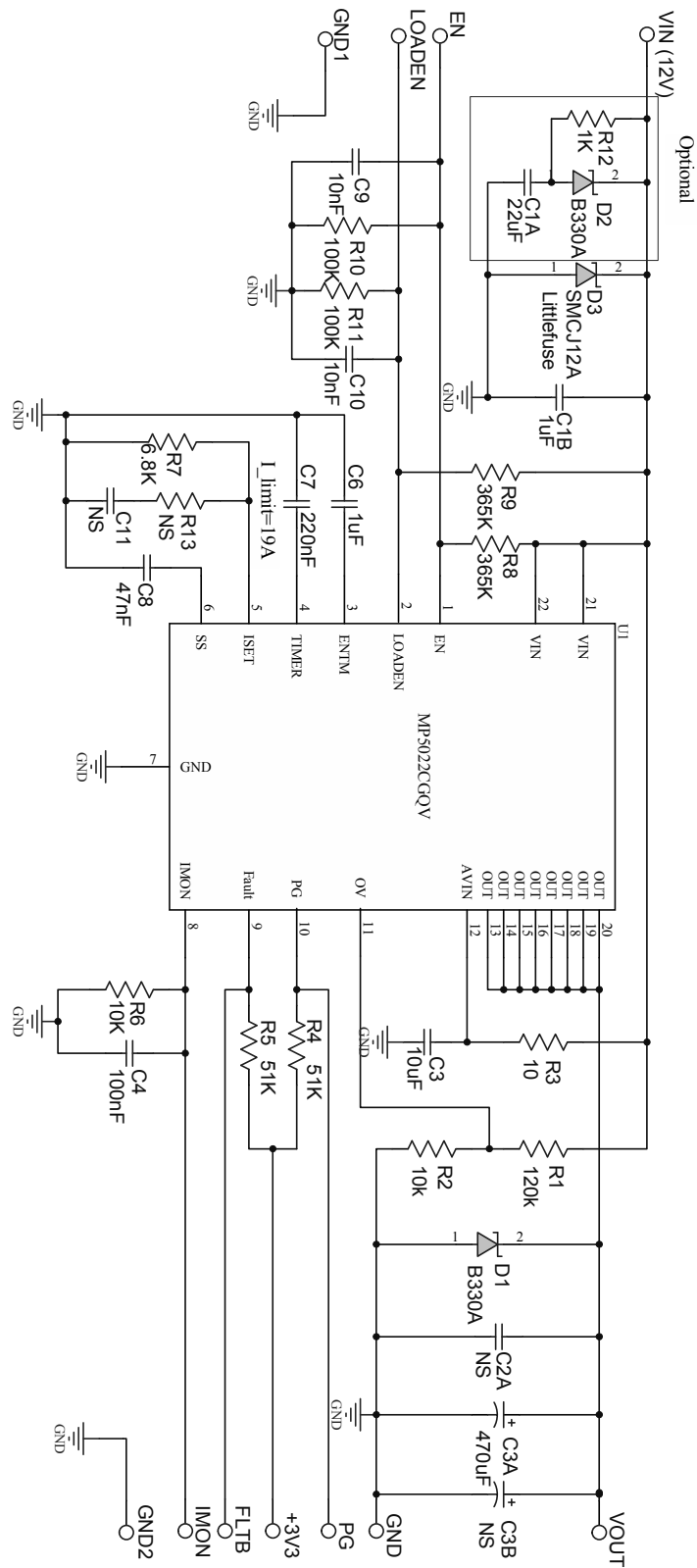

**EV5022C-QV-00A BILL OF MATERIALS**

Qty	RefDes	Value	Description	Package	Manufacturer	Manufacturer P/N
1	C1A	22μF	Ceramic Cap., 25V, 10%, X5R	1206	muRata	GRM31CR61E226KE15
1	C1B	1μF	Ceramic Cap., 50V, 10%, X7R	0805	muRata	GRM21BR71H105KA12L
1	C3A	220uF	Electrolytic Cap., 35V	DIP	江海	CD110-35V220
1	C3	10μF	Ceramic Cap., 25V, 10%, X6S	0805	muRata	GRM21BC81E106KE11L
1	C4	0.1μF	Ceramic Cap., 25V, 10%, X7R	0603	muRata	GRM188R71E104KA01D
1	C6	1μF	Ceramic Cap., 16V, 10%, X7R	0603	muRata	GRM188R71C105KA12D
1	C7	220nF	Ceramic Cap., 16V, 10%, X7R	0603	muRata	GRM188R71C224KA01D
1	C8	47nF	Ceramic Cap., 50V, 10%, X7R	0603	muRata	GRM188R71H473KA01D
2	C9,C10	10nF	Ceramic Cap., 50V, 10%, X7R	0603	muRata	GRM188R71H103KA01D
1	C11	NS				
1	R1	71.5k	Film Res., 1%	0603	Yageo	RC0603FR-0771K5L
2	R2,R6	10k	Film Res., 1%	0603	Yageo	RC0603FR-0710KL
1	R3	100Ω	Film Res., 5%	0603	Yageo	RC0603JR-07100RL
2	R4,R5	510k	Film Res., 1%	0603	Yageo	RC0603FR-07510KL
1	R7	6.8k	Film Res., 1%	0603	Yageo	RC0603FR-076K8L
2	R8, R9	365k	Film Res., 1%	0603	Yageo	RC0603FR-07365KL
2	R10,R11	100k	Film Res., 1%	0603	Yageo	RC0603FR-07100KL
1	R12	1k	Film Res., 1%	1206	Hottechohm	RI1206L1001FT
1	R13	NS				
2	D1,D2	B330A	Schottky Diode;30V;3A;	SMA	Diodes	B330A
1	D3	SMCJ12A	TVS Diode; 12V	SMC	Littlefuse	SMCJ12A
4	VIN,VOUT,GND	connector	Power pins	TP2MM		
5	PG,+3.3V,GND,FLT,IMON.	connector	Test point pins	TP1MM		
1	CN1	connector	5pin 2.54mm			
1	U1	IC	Hot Swap Protection device	QFN22(3*5mm)	MPS	MP5022CGQV

### PRINTED CIRCUIT BOARD LAYOUT

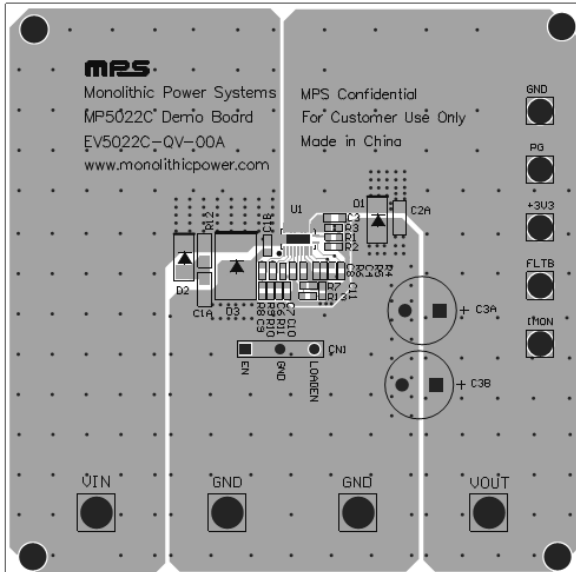

Figure 1—Top Silk Layer +Top Layer

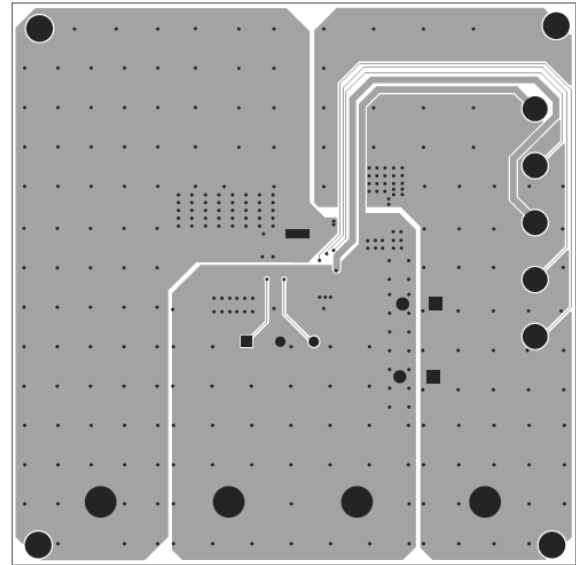

Figure 2—Bottom Layer

## QUICK START GUIDE

The board layout accommodates most commonly used schottky and output capacitors.

1. Attach the positive and negative terminals of the load to the VOUT and GND terminals on demo board, respectively.
2. Preset the power supply output to be 12V, and then turn off the power supply.
3. Attach the positive and negative terminals of the power supply to the VIN and GND terminals on demo board, respectively.
4. Turn on the power supply. The MP5022C will automatically start up.
5. To use the EN turning on function, apply a digital input to the EN pin. Drive EN higher than 2V to turn on the hot swap or less than 0.4V to turn it off.
6. To use PG and FLT B indicating function, connect +3V3 and GND terminals on demo board to a 3.3V power supply.

**NOTICE:** The information in this document is subject to change without notice. Users should warrant and guarantee that third party Intellectual Property rights are not infringed upon when integrating MPS products into any application. MPS will not assume any legal responsibility for any said applications.